

! Contact our sales office for delivery dates and prices as this is a special model.

Specialized Product

Point to Group  
**P.G.** information

## Speed Controller/In-line Type

Stainless Steel 316 and Special Temperature Environment (-45°C) Specifications

**AS2000-N02-X800/AS3000-N03-X800**  
**AS4000-N04-X800**

Features

### Improved environmental resistance

External/Internal parts material: All stainless steel 316  
Ambient and fluid temperature: -45 to 80°C

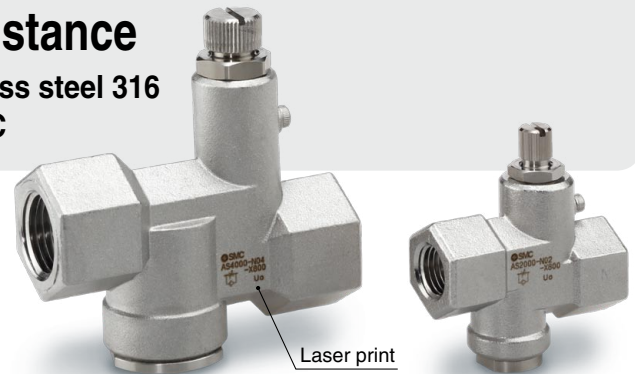

### Application example:

Process valve Open/Close speed control

In water dispersing environments

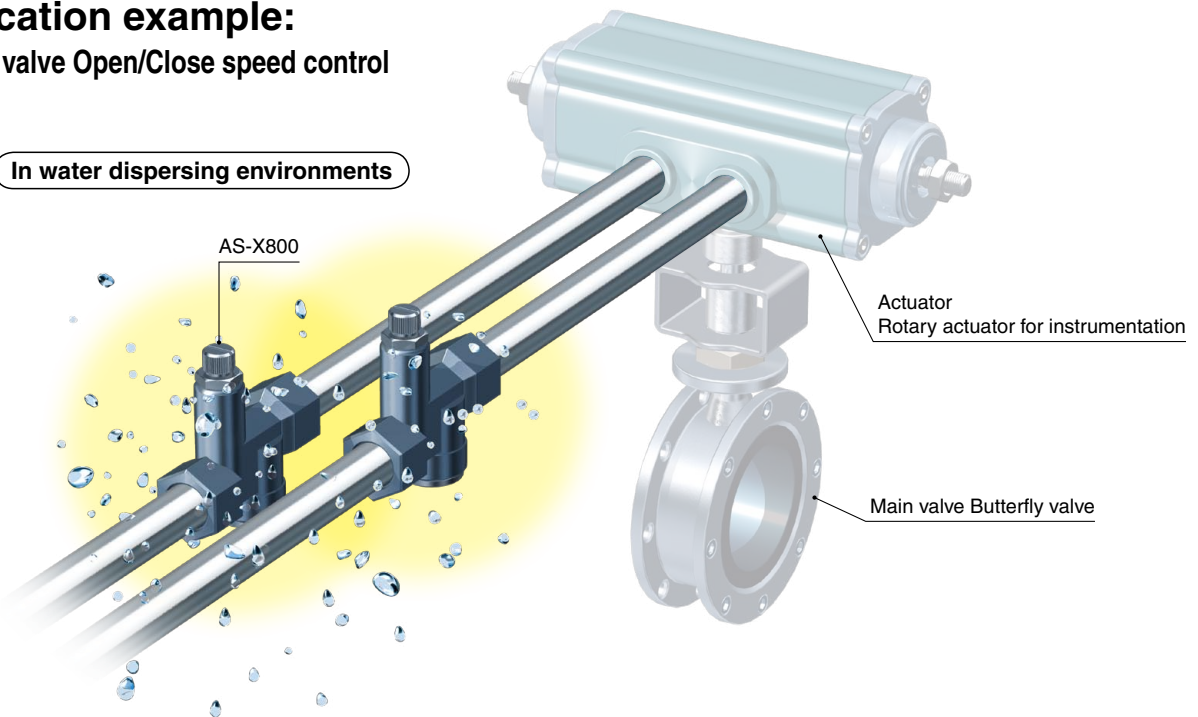

### Specifications

Fluid	Air
Proof pressure	2 MPa
Operating pressure range	0.05 to 1 MPa
Ambient and fluid temperature	-45 to 80°C (No freezing)



### Caution

To ensure the safest possible operation of this product, please be sure to thoroughly read the "Safety Instructions" in our "Best Pneumatics" catalog before use.

SMC Corporation 4-14-1, SOTO-KANDA, CHIYODA-KU, TOKYO 101-0021, JAPAN URL: <http://www.smcworld.com>

©2016 SMC Corporation All Rights Reserved



SP153X-016E  
P: UY

Ⓐ

## Flow Characteristics

AS2000-N02-X800

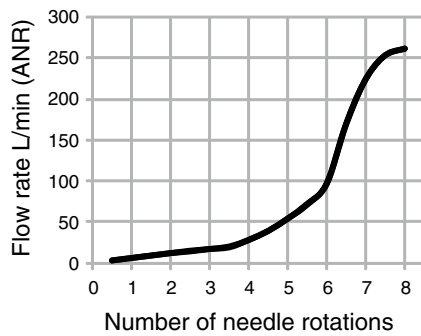

AS3000-N03-X800

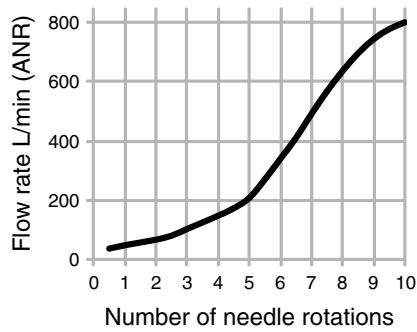

AS4000-N04-X800

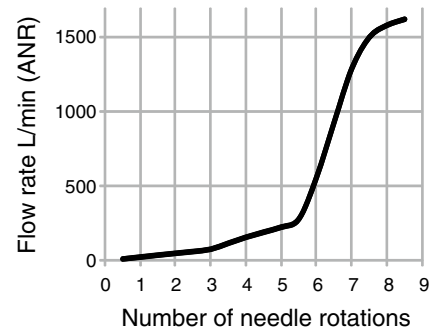

## How to Order

AS **2** 000 - N **02** - X800

Body size

2	1/4
3	3/8
4	1/2

Thread type

N	NPT
---	-----

Port size

02	1/4
03	3/8
04	1/2

In-line type	Port size		
	NPT1/4	NPT3/8	NPT1/2
AS2000	●	—	—
AS3000	—	●	—
AS4000	—	—	●

## Dimensions

[mm]

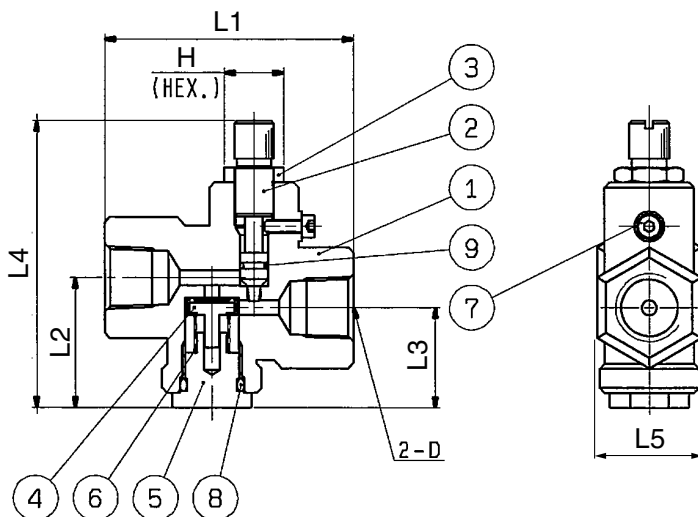

### Component Parts

No.	Description	Material
1	Body	SCS14A (SUS 316)
2	Needle	SUS316
3	Lock nut	SUS316
4	Valve	SUS316
5	Valve guide	SUS316, NBR for low temperature
6	Spring	SUS316
7	Bolt	SUS316
8	O-ring	NBR for low temperature
9	O-ring	NBR for low temperature

Model	Port size D	H	L1	L2	L3	L4 (Note)		L5	Mass g
						MAX.	MIN.		
AS2000-N02-X800	NPT1/4	12	50	26	20	62	58	21	170
AS3000-N03-X800	NPT3/8	12	60	26	17	71	64	24	250
AS4000-N04-X800	NPT1/2	17	81	36	22	92	83	30	480

Note) Reference dimensions