

MY3M Series

ø16, ø25, ø40, ø63



Construction

The seal belt has been changed since June 2015 (Lot no. TT). When replacing the seal belt of a cylinder that was purchased before the change, order the belt clamp shown in the table below only for ø40 size. Lot number checking method → p. 564

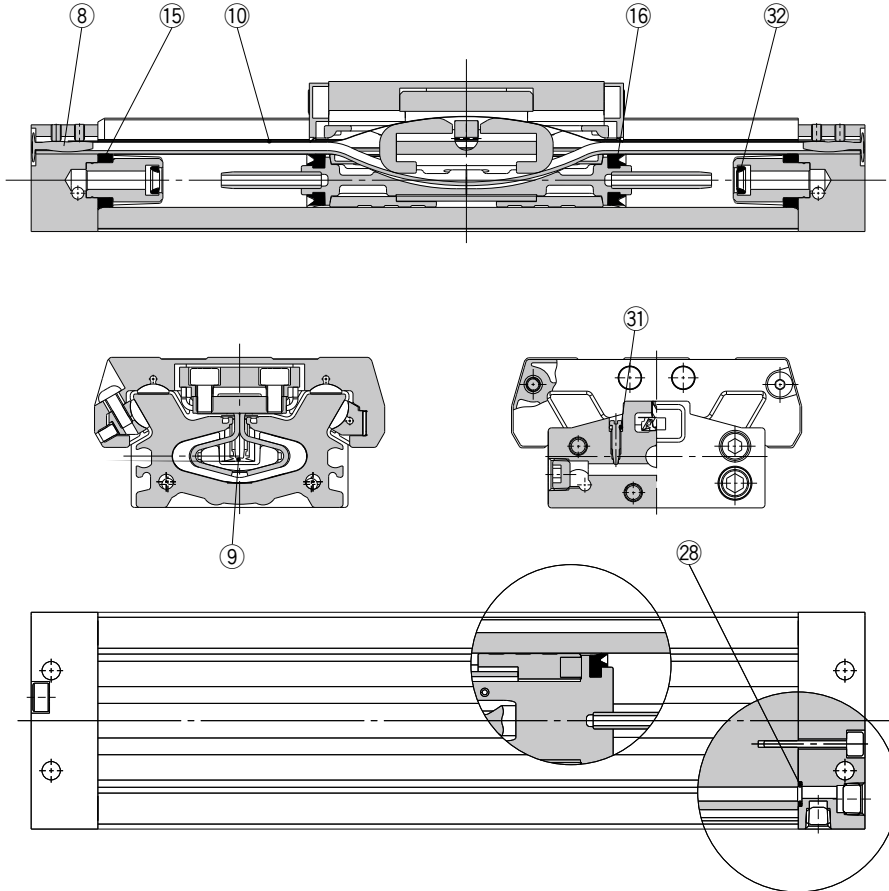

* The numbers correspond with those in the "Construction" of the MY3 series in the Best Pneumatics catalog.

Replacement Parts: Seal Kit (8, 9, 10, and 31 are not included in the seal kit. Order them as required with the individual part numbers provided.)

No.	Description	Material	Qty.	MY3M16	MY3M25	MY3M40	MY3M63
8	Belt clamp	Polybutylene terephthalate	1	—	—	MYA40-31-R6658B	—
9	Seal belt	Urethane Polyamide	1	MY3B16-16C-Stroke	MY3B25-16C-Stroke	MY3B40-16C-Stroke	MY3B63-16A-Stroke
10	Dust seal band	Stainless steel	1	MY3B16-16B-Stroke	MY3B25-16B-Stroke	MY3B40-16B-Stroke	MY3B63-16B-Stroke
31	O-ring	NBR	2	KA00309 (ø4 x ø1.8 x ø1.1)	KA00309 (ø4 x ø1.8 x ø1.1)	KA00320 (ø7.15 x ø3.75 x ø1.7)	KA00402 (ø8.3 x ø4.5 x ø1.9)
15	Tube gasket	NBR	2	MY3B16-PS	MY3B25-PS	MY3B40-PS	MY3B63-PS
16	Piston seal	NBR	2				
28	O-ring	NBR	4				
32	Cushion seal	NBR	2				

* Since the seal kit does not include a grease pack, it should be ordered separately.
Grease pack part no.: GR-S-010 (10 g)