

MGC Series

ø20, ø25, ø32, ø40, ø50

Construction: With Rear Plate

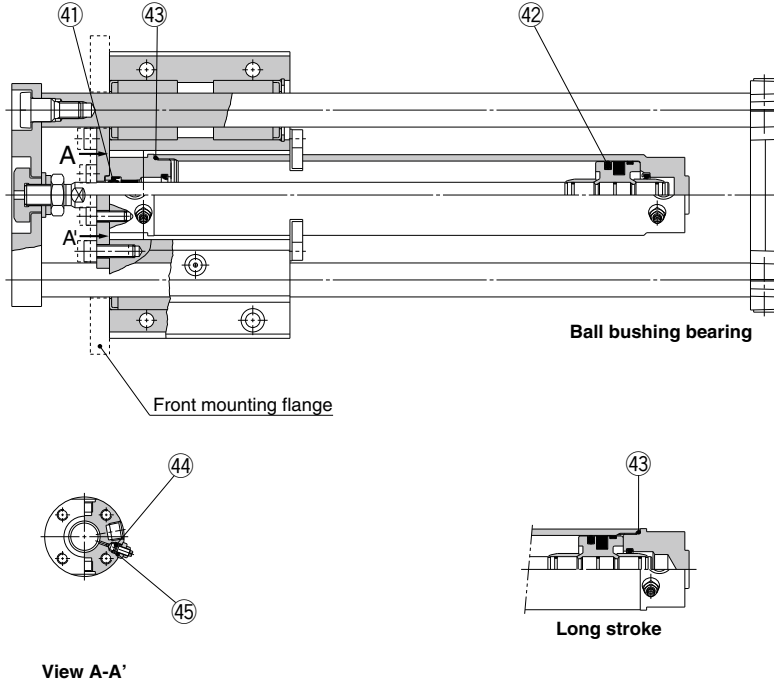

* The numbers correspond with those in the "Construction" of the MGC series in the Best Pneumatics catalog.

Seal Kit List

No.	Description	Material	Note
④①	Rod seal	NBR	
④②	Piston seal		
④③	Tube gasket		
④④	Valve seal		
④⑤	Valve retainer gasket		

Replacement Parts: Seal Kit

Bore size (mm)	Part no.	Contents
20	CG1A20-PS	Set of nos. ④①, ④②, ④③, ④④, ④⑤
25	CG1A25-PS	
32	CG1A32-PS	
40	CG1A40-PS	

* The seal kit includes ④① to ④⑤. Order the seal kit based on each bore size.

* The seal kit includes a grease pack (10 g). Order with the following part number when only the grease pack is required.

Grease pack part no.: GR-S-010 (10 g)

⚠ Caution

When disassembling base cylinders with bore sizes of ø20 through ø40, grip the double flat part of either the tube cover or the rod cover with a vise and loosen the other side with a wrench or an adjustable angle wrench, and then remove the cover. When retightening, tighten approximately 2 degrees more than the original position. (Cylinders with ø50 or larger bore sizes are tightened with a large tightening torque and cannot be disassembled. Please contact SMC when disassembly is required.)