



ORIGINAL INSTRUCTIONS

Instruction Manual

Space Saving Vacuum Unit

Series ZQ□A

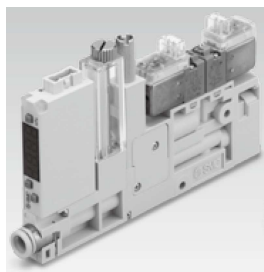

Single Unit

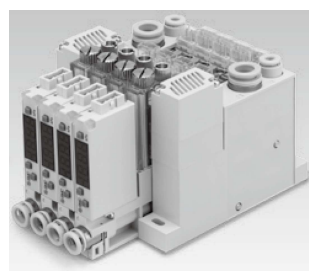

Manifold

The intended use of the vacuum unit is to generate vacuum and control the operation of suction and release.

1 Safety Instructions

These safety instructions are intended to prevent hazardous situations and/or equipment damage. These instructions indicate the level of potential hazard with the labels of "Caution," "Warning" or "Danger." They are all important notes for safety and must be followed in addition to International Standards (ISO/IEC) ¹⁾, and other safety regulations.

¹⁾ ISO 4414: Pneumatic fluid power - General rules relating to systems.
ISO 4413: Hydraulic fluid power - General rules relating to systems.
IEC 60204-1: Safety of machinery - Electrical equipment of machines. (Part 1: General requirements)
ISO 10218-1: Manipulating industrial robots -Safety. etc.

- Refer to product catalogue, Operation Manual and Handling Precautions for SMC Products for additional information.
- Keep this manual in a safe place for future reference.

	Caution	Caution indicates a hazard with a low level of risk which, if not avoided, could result in minor or moderate injury.
	Warning	Warning indicates a hazard with a medium level of risk which, if not avoided, could result in death or serious injury.
	Danger	Danger indicates a hazard with a high level of risk which, if not avoided, will result in death or serious injury.

Warning

- Always ensure compliance with relevant safety laws and standards.
- All work must be carried out in a safe manner by a qualified person in compliance with applicable national regulations.

2 Specifications

General Specifications

Ambient temperature range [°C]	5 to 50(no condensation)
Fluid	Air
Vibration resistance [m/s ²] ¹⁾	20
Impact resistance [m/s ²] ²⁾	100

Note *1) 10 to 150 Hz for 2 hours in each direction of X, Y and Z (De-energized, Initial valve)

Note *2) 3 times in each direction of X, Y and Z (De-energized, Initial valve)

Vacuum Ejector Specifications

Model	ZQ05□A	ZQ07□A	ZQ10□A
Nozzle diameter [mm]	0.5	0.7	1.0
Standard supply pressure [MPa]	0.35	0.43	
Max vacuum pressure [kPa] ¹⁾	-80		
Max suction flow rate [L/min(ANR)] ¹⁾	5	10	22
Air consumption [L/min(ANR)] ¹⁾	15	25	47
Supply pressure range [MPa]	P Port	0.3 to 0.5	
	PD Port ²⁾	0 to 0.45 (0.1 to 0.45)	

Note *1) Values are at the same standard supply pressure and based on SMC's measurement standards. They depend on atmospheric pressure (weather, altitude, etc.) and measurement method.

Note *2) Must be 0.05MPa or lower than P Port pressure

Port Types: P: Air supply port, PD: Vacuum release port, PV: Common vacuum supply pressure port, PS: Common pilot pressure supply port
() :With Energy Saving Vacuum Pressure Switch

Vacuum Pump System Specifications

Model	ZQ000□A	
Flow rate characteristics of V to PV ¹⁾	C [dm ³ /(s·bar)]	0.31
	B	0.23
	Cv	0.09
Flow rate characteristics of PS to V ¹⁾	C [dm ³ /(s·bar)]	0.24
	B	0.26
	Cv	0.08
Supply pressure range	PV port [kPa]	0 to -101.3
	PS port [MPa]	0.3 to 0.5
	PD port [MPa] ²⁾	0 to 0.45

Note *1) When needle is fully open. Note *2) Must be 0.05MPa or more lower

than PS Port pressure

Vacuum Pressure Switch Specifications

Model	ZSE10			
	Vacuum Pressure	Compound Pressure	Energy saving pressure	
Rated pressure range	0 to -101 kPa	-100 to 100 kPa		
Set pressure range	10 to -105 kPa	-105 to 105 kPa		
Withstand pressure	500kPa			
Minimum setting unit	0.1kPa			
Power supply voltage	12 to 24 VDC ±10%, Ripple (p-p) 10% or less (with power supply polarity protection)			
Current consumption	40 mA or less			
Switch output	NPN or PNP open collector: 2 outputs (selectable)		NPN or PNP. Output 1: General purpose, Output 2: Valve control	
	Max load current	80mA		
	Max applied voltage	28V (NPN output)	26.4V(NPN output)	
	Residual voltage	2V or less (with 80mA load current)		
	Response time	2.5 ms or less (Response time selections with anti-chattering function: 20, 100, 500, 1000 and 2000 ms)		
	Short circuit protection	With short-circuit protection		
Repeatability	±0.2% F.S. ±1 digit			

Specifications- continued

Vacuum Pressure Switch Specifications- continued

Model	ZSE10			
	Vacuum Pressure	Compound Pressure	Energy saving pressure	
Hysteresis	Hysteresis mode	Variable (0 or above) Note 1)		
	Window comparator mode	Variable (o or above)	-	
Analog output	Voltage output	Output voltage	1 to 5 V ±2.5% F.S.	-
		Linearity	±1% F.S. or less	-
		Impedance	Approx. 1 kΩ	-
Display system	3 1/2-digit, 7 segment LED 1-color display (Red)			
Display accuracy	±2% F.S. ±1 digit (at ambient temperature of 25 ±3°C)			
Indicator light	Lights when ON, OUT1: Green, OUT2: Red			
Environmental resistance	Enclosure	IP40		
	Ambient humidity range	Operating/Stored: 35 to 85% RH (with no condensation)		
	Withstand voltage	1000 VAC for 1 min. between terminals and housing		
Temperature Characteristics	Insulation resistance	50 MΩ or more (500 VDC measured via megohmmeter) between terminals and housing		
		±2% F.S. (at 25°C of ambient temperature range between -5 and 50°C)		
Lead wires	Oil-resistant cabtire cord Cross section: 0.15 mm ² (AWG26), 5 cores, Conductor O.D.: 1.0 mm			

Supply and Release Valve Specifications

Type	Normally Closed	Normally Open
Model	Z1-V114-5LU	ZQ1-V124-5MU-A
Manual override	Non-locking push type/slotted locking type	
Rated coil voltage	24 DCV	
Allowable voltage fluctuation	-10 to 10%	
Power consumption	0.4W at start-up, 0.1W at holding (power saving circuit)	
Lead wire entry	L-shaped plug connector (with light/surge voltage suppressor)	M-shaped plug connector (with light/surge voltage suppressor)
Lead wire	Conductor effective area 0.2 to 0.33 mm ² , Maximum outer sheath O.D. 1.7 mm	

Refer to catalogue for more details

3 Installation

3.1 Installation

Warning

- Do not install the product unless the safety instructions have been read and understood.
- When mounting the product, tighten it with the recommended tightening torque (0.54 to 0.66 N•m).
- When mounting the manifold product, use the attached washers.
- When installing the product, secure the space required for maintenance and inspection of the product
- Do not drop, hit, or apply excessive impact to the product.

Installation - continued

3.2 Environment

Warning

- Do not use in an environment where corrosive gases, chemicals, salt water or steam are present.
- Do not use in an explosive atmosphere.
- Do not expose to direct sunlight. Use a suitable protective cover.
- Do not install in a location subject to vibration or impact in excess of the product's specifications.
- Do not mount in a location exposed to radiant heat that would result in temperatures in excess of the product's specifications
- The suction filter used in this product is a simple one. If there is a lot of dust in the usage environment, please consider using a suction filter (ZFC series, etc.).
- Do not use in place where static electricity build-up can occur.
- Do not use in an environment where surges occur.

3.3 Air Supply

Caution

- Do not use air containing chemicals, synthetic oils containing organic solvents, salts, or corrosive gases.
- Recommended quality of the supplied air be equivalent to the compressed air cleanliness grade "2: 6: 3" according to ISO8573-1: 2010.
- Do not supply the pressure in excess of the product's specifications.

3.4 Piping

Caution

- Before connecting piping make sure to clean up chips, cutting oil, dust, etc.
- When piping pipe fittings to the pilot pressure exhaust (PE) port (M3) of the single specification, fix the parts where the port is installed, tighten by hand, and then use an appropriate tool to make about 1/4 turn. (Recommended tightening torque: 0.4 to 0.5 Nm)
- When piping pipe fittings to the pilot pressure exhaust (P) port, etc. (M5) of the single specification, fix the parts where the port is installed, tighten by hand, and then use an appropriate tool to make about 1/6 to

1/4 turn. (Recommended tightening torque: 1.0 to 1.5 Nm)

- When piping the tube to the one-touch fitting, grasp the tube, slowly insert it into the one-touch fitting, and insert it all the way in. After inserting it all the way, pull the tube lightly and check that it does not come off.

3.5 Wiring to the solenoid valve and pressure switches

Refer to the operation manual of solenoid valve (V100 series) and pressure switch (ZSE10 series). Manuals can be found by the links below:
ZSE10: <https://www.smcworld.com/manual/en-jp/?k=zse10>
V100: <https://www.smcworld.com/manual/en-jp/?k=V100>

4 Settings

4.1 Manual Override (With supply valve and release valve)

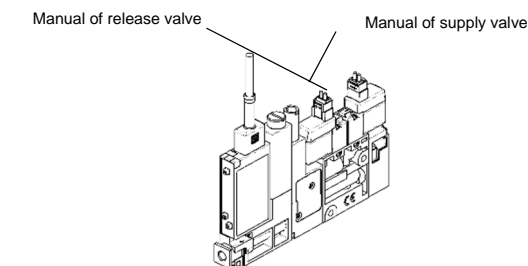

Refer to the operation manual of the solenoid valve V100 series for the manual operation method.

Settings- continued

4.2 Release flow adjusting needle

When the release valve is turned on, vacuum release air is let out. The release flow adjusting needle allows to control the vacuum break air flow rate.

Loosen the lock nut and use a flat-blade screwdriver to adjust the release flow rate adjustment needle at the back of the lock nut.

The breaking flow rate adjustment needle can be turned clockwise to reduce the release flow rate, and counterclockwise to increase the release flow rate.

After adjusting the release flow rate adjustment needle, tighten the lock nut to fix the adjustment position.

5 How to Order

Refer to the catalogue for 'How to Order'.

6 Outline Dimensions (mm)

Refer to the catalogue for outline dimensions.

7 Maintenance

7.1 General Maintenance

Caution

- Not following proper maintenance procedures could cause the product to malfunction and lead to equipment damage.
- If handled improperly, compressed air can be dangerous.
- Maintenance of pneumatic systems should be performed only by qualified personnel.
- Before performing maintenance, turn off the power supply and be sure to cut off the supply pressure. Confirm that the air is released to atmosphere.
- After installation and maintenance, apply operating pressure and power to the equipment and perform appropriate functional and leakage tests to make sure the equipment is installed correctly.
- If any electrical connections are disturbed during maintenance, ensure they are reconnected correctly, and safety checks are carried out as required to ensure continued compliance with applicable national regulations.
- Do not make any modification to the product.
- Do not disassemble the product, unless required by installation or maintenance instructions

- Implement the maintenance and check shown below to use the space saving vacuum unit safely and in an appropriate way for a long period of time.
- Drain the air filter and mist separator regularly
- Replace the sound absorbing material (silencer) built into the ejector regularly
- Refer to the online operation manual for replacement parts.
- Do not use benzene or thinner for cleaning

7.2 Sound absorbing material replacement method

Single Unit

- 1) Loosen the assembly screws (2 pieces) of the silencer plate and remove the silencer plate (2 pieces) and the sound absorbing material.
- 2) Replace the silencer plate (2 sheets) and the sound absorbing material.
- 3) Assemble the silencer plate with the assembly screws.
(Recommended tightening torque: 0.028 to 0.032 Nm)

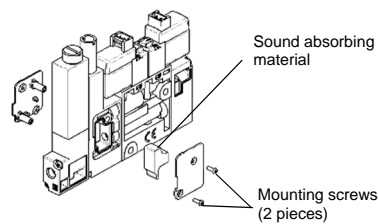

Maintenance- continued

Manifold

- 1) Loosen the two assembly screws of the silencer block and remove the silencer block.
- 2) Replace the sound absorbing material built into the silencer block.
- 3) Assemble the silencer block with the assembly screws.
(Recommended tightening torque: 0.25 to 0.31 Nm)

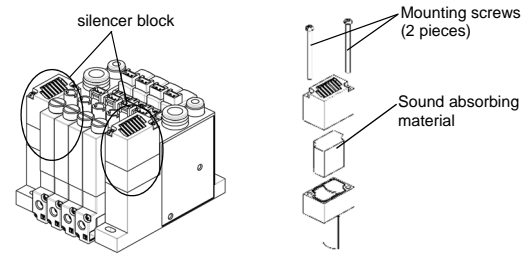

Filter element replacement method

- 1) Loosen the tension bolt and remove the filter case.
- 2) Replace the filter element built into the filter case.
- 3) Assemble the filter case with tension bolts.
(Recommended tightening torque: 0.12 to 0.18 Nm)

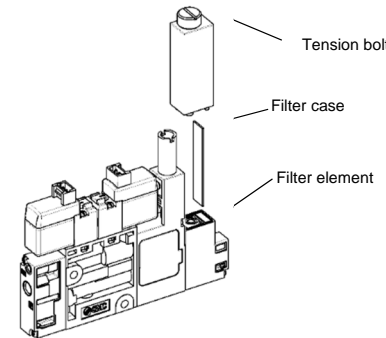

8 Limitations of Use

8.1 Limited warranty and Disclaimer/Compliance Requirements

Refer to Handling Precautions for SMC Products.

Caution

• Exhaust from Space saving vacuum unit (ejector system)

- 1) For the silencer exhaust type, make sure that there is no obstruction around the exhaust port.
- 2) In the case of port exhaust type, exhaust resistance may be affected depending on the pipe diameter and length, so make sure that the back pressure is 1 kPa or less.
- 3) Do not block the exhaust port.

• Ejector exhaust noise

When the vacuum ejector generates a vacuum, an intermittent noise (abnormal noise) may be generated from the exhaust section near the standard supply pressure where the vacuum pressure peaks, and the vacuum pressure may not be constant. There is no problem in use as long as the vacuum pressure range is sufficient for adsorption, but if you are concerned about the sound or affect the setting of the pressure switch, slightly change the supply pressure and reduce the range of the intermittent sound. Please avoid it.

• About the release flow rate adjusting needle

- 1) Leakage cannot be reduced to zero when the needle is fully closed.
- 2) Since the release flow rate adjustment needle has a retaining mechanism, it will not rotate beyond the rotation stop position. If you try to turn the needle any further, it may be damaged.
- 3) When tightening the lock nut, tighten it by hand to about 15 to 30 degrees, and be careful not to damage it due to overtightening.

• About solenoid valve and pressure switch

For the solenoid valve (V100 series) and pressure switch (ZSE10 series), refer to each instruction manual.

9 Product disposal

This product should not be disposed of as municipal waste. Check your local regulations and guidelines to dispose this product correctly, in order to reduce the impact on human health and the environment.

10 Contacts

Refer to www.smcworld.com or www.smc.eu for your local distributor/importer.

SMC Corporation

URL : <https://www.smcworld.com> (Global) <https://www.smc.eu> (Europe)
SMC Corporation, 4-14-1, Sotokanda, Chiyoda-ku, Tokyo 101-0021, Japan
Specifications are subject to change without prior notice from the manufacturer.
© 2021 SMC Corporation All Rights Reserved.
Template DKP50047-F-085M