

Instruction Manual

3 Port Solenoid Valve

Series VK300

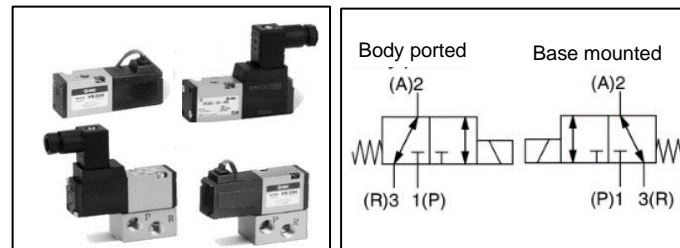

The intended use of this product is to control the movement of an actuator.

1 Safety Instructions

These safety instructions are intended to prevent hazardous situations and/or equipment damage. These instructions indicate the level of potential hazard with the labels of "Caution," "Warning" or "Danger."

They are all important notes for safety and must be followed in addition to International Standards (ISO/IEC)⁽¹⁾, and other safety regulations.

⁽¹⁾ ISO 4414: Pneumatic fluid power - General rules relating to systems.

ISO 4413: Hydraulic fluid power - General rules relating to systems.

IEC 60204-1: Safety of machinery - Electrical equipment of machines.

(Part 1: General requirements)

ISO 10218-1: Robots and robotic devices - Safety requirements for industrial robots - Part 1: Robots.

- Refer to product catalogue, Operation Manual and Handling Precautions for SMC Products for additional information.
- Keep this manual in a safe place for future reference.

	Caution	Caution indicates a hazard with a low level of risk which, if not avoided, could result in minor or moderate injury.
	Warning	Warning indicates a hazard with a medium level of risk which, if not avoided, could result in death or serious injury.
	Danger	Danger indicates a hazard with a high level of risk which, if not avoided, will result in death or serious injury.

Warning

- Always ensure compliance with relevant safety laws and standards.**
- All work must be carried out in a safe manner by a qualified person in compliance with applicable national regulations.
- If this equipment is used in a manner not specified by the manufacturer, the protection provided by the equipment may be impaired.

Caution

The product is provided for use in manufacturing industries only. Do not use in residential premises.

2 Specifications

2.1 Valve specification

Fluid	Air	
Operating pressure range [MPa]	Standard	0 to 0.7
	Low wattage (Y)	
	Continuous duty (E)	
Flow characteristics	Refer to catalogue	
Ambient and fluid temperature [°C]	-5 to 50 (no freezing)	
Response Time (at 0.5 MPa) [ms] ^{Note 1)}	≤10 (Standard)	
	≤15 (Low power consumption type)	
Duty cycle	Contact SMC	
Minimum operating frequency	1 cycle / 30 days	
Maximum operating frequency [Hz]	10	
Manual override	Non-locking push type	
Lubrication	Not required	
Impact / Vibration resistance [m/s ²] ^{Note 2)}	300 / 50	
Enclosure	IP30 (based on IEC60529)	

2 Specifications - continued

Mounting orientation	Unrestricted	
Weight [g]	VK332#: 80	VK334#: 120

Table 1.

Note 1) Based on dynamic performance test, JIS B 8419: 2010. (Coil temperature: 20°C, at rated voltage, without surge suppressor).

Note 2) **Impact resistance:** No malfunction occurred when it is tested with a drop tester in the axial direction and at the right angles to the main valve and armature in both energized and de-energized states every once for each condition. (Values quoted are for a new valve).

Vibration resistance: No malfunction occurred in a one-sweep test between 45 and 2000 Hz. Test was performed at both energized states in the axial direction and at the right angles to the main valve and armature. (Values quoted are for a new valve).

2.2 Solenoid specification

Electrical entry	Grommet (G, H), DIN terminal (D, DO)			
Rated coil voltage [V]	AC (50 / 60 Hz)	100, 110, 200, 220, 240		
	DC	12, 24		
Allowable voltage fluctuation ^{Note 1)}	±10% of rated voltage			
Apparent power [VA] ^{Note 2)}	Standard type	Inrush	50 Hz	9.5
			60 Hz	8
	Holding	50 Hz	7	
		60 Hz	5	
Power consumption [W]	Without indicator light		4	
	With indicator light		4.3	
Surge voltage suppressor	AC	Varistor		
	DC	Diode (12 VDC or less: Varistor)		
Indicator light	AC	Neon bulb		
	DC	LED		

Table 2.

Note 1) Valve state is not defined if electrical input is outside of specified operating ranges.

Note 2) At the rated voltage.

2.3 Low wattage VK33# (Y, W) and continuous duty VK33#E types

- Specifications different from standard are as follows:

Apparent power [VA]	AC	Inrush	50 Hz	3.5
			60 Hz	3.3
		Holding	50 Hz	3
			60 Hz	2.8
Power consumption [W]	DC	Without indicator light: 2		
		With indicator light: 2.3		

Table 3.

Caution

- If the valve is to be energized for periods of long ON time, continuous duty VK33#E type is recommended. This model is for continuous duty, not for high cycle rates. But even in low cycle rates, if energizing the valve for more than one once-a-day, please contact SMC.

2.4 Vacuum type VK33# (V, W)

- In contrast to the standard product, this vacuum model has less air leakage at low pressures, a feature that should be taken into consideration when using this valve for vacuum applications.

- Specifications different from standard are as follows:

Operating pressure range [MPa]	-101.2 kPa to 0.1
--------------------------------	-------------------

Table 4.

Caution

- Since this valve has slight air leakage, it cannot be used for vacuum holding (including positive pressure holding) in the pressure container.

2.5 Light indication

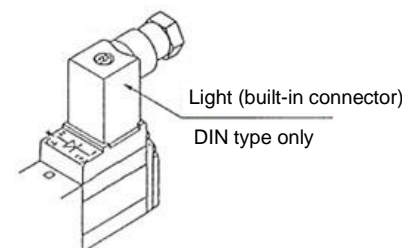

Figure 1.

2 Specifications - continued

2.6 Special products

Warning

Special products (-X) might have specifications different from those shown in this section. Contact SMC for specific drawings.

3 Installation

3.1 Installation

Warning

- Do not install the product unless the safety instructions have been read and understood.
- When mounting a valve on the manifold base or sub-plate, etc., the mounting orientation is already decided. If mounted in a wrong direction, the equipment to be connected may result in malfunction (see Figures 10 and 11 under section 3.13). VK300 series valves can be mounted on the manifold base VV5K3 of VK3000 series. Refer to catalogue for more details.

3.2 Environment

Warning

- Do not use in an environment where corrosive gases, chemicals, salt water or steam are present.
- Do not use in an explosive atmosphere.
- Do not expose to direct sunlight. Use a suitable protective cover.
- Do not install in a location subject to vibration or impact in excess of the product's specifications.
- Do not mount in a location exposed to radiant heat that would result in temperatures in excess of the product's specifications.
- When the solenoid valve is mounted in a control panel or it is energized for a long time, make sure that the ambient temperature is within the specification of the valve.
- If using in an atmosphere where there is possible contact with water droplets, oil, weld spatter, etc., take suitable preventive measures.
- Do not use in high humidity environment where condensation can occur.
- Contact SMC for altitude limitations.

3.3 Piping

Caution

- Before connecting piping make sure to clean up chips, cutting oil, dust etc.
- When installing piping or fittings, ensure sealant material does not enter inside the port. When using seal tape, leave 1 thread exposed on the end of the pipe/fitting.
- Tighten fittings to the specified tightening torque.

Port	Connection thread size (R, NPT)	Tightening Torque [N·m]
1(P), 2(A), 3(R)	M5	1 to 1.5
	1/8	3 to 5

Table 5.

3.4 Lubrication

Caution

- SMC products have been lubricated for life at manufacture, and do not require lubrication in service.
- If a lubricant is used in the system, refer to catalogue for details.

3.5 Air supply

Warning

- Use clean air. If the compressed air supply includes chemicals, synthetic materials (including organic solvents), salinity, corrosive gas etc., it can lead to damage or malfunction.

Caution

- Install an air filter upstream of the valve. Select an air filter with a filtration size of 5 µm or smaller.

3.6 Effect of back pressure when using a manifold

Caution

- Use caution when valves are used on a manifold, because an actuator may malfunction or unexpected movement may occur due to back pressure.
- For single acting cylinder, take appropriate measures to prevent malfunction by using it with an individual exhaust manifold.

3 Installation - continued

3.7 Light/surge voltage suppressor

3.7.1 AC circuit

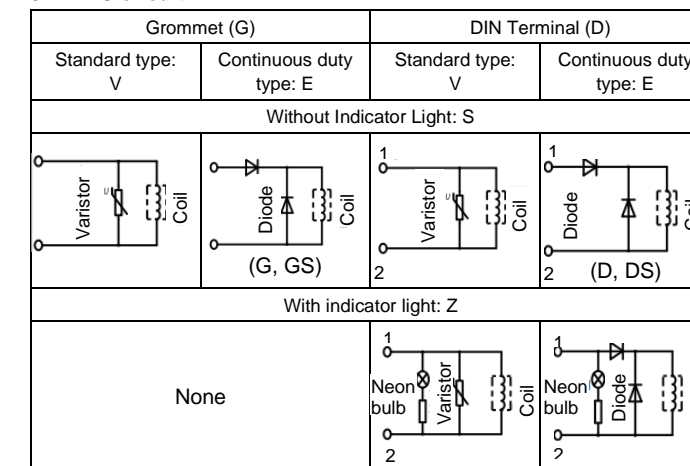

Figure 2.

3.7.2 DC circuit (24V, 48V)

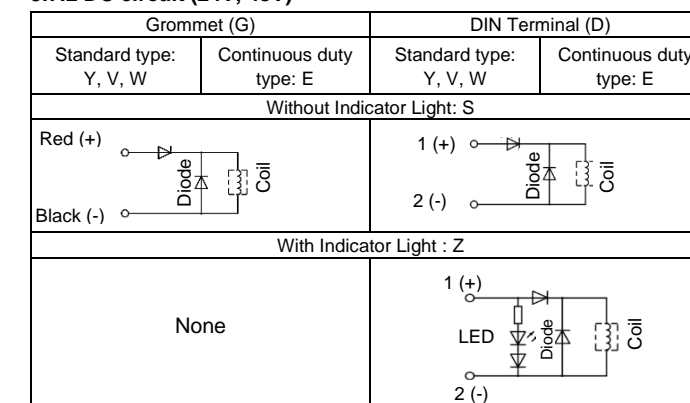

Figure 3.

3.7.3 DC circuit (6V, 12V)

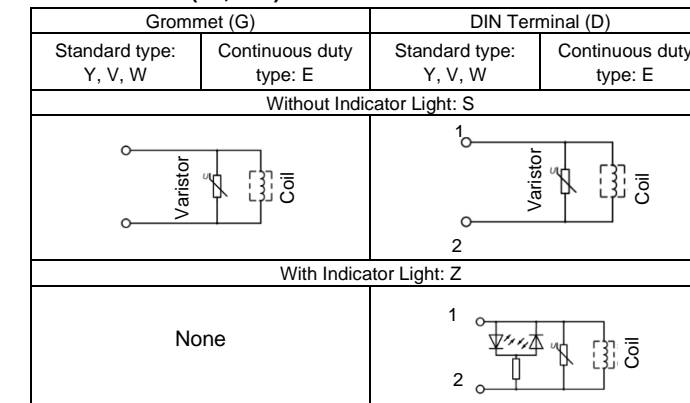

Figure 4.

Caution

In the case of valves without surge suppressor, the machine designer shall add suppression as close as possible to the valve.

3 Installation - continued

3.7.4 Electrical connectors

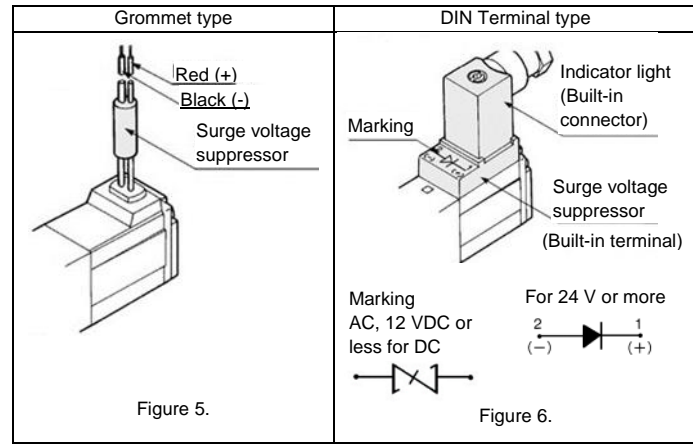

3.8 Residual voltage of the surge voltage suppressor

Caution

- If a varistor or diode surge voltage suppressor is used, the suppressor arrests the back EMF voltage from the coil to approximately 1 V.
- Ensure the transient voltage is within the specification of the host controller.
- Valve response time is dependent on surge suppression method selected.

3.9 Countermeasure for surge voltage

Caution

- At times of sudden interruption of the power supply, the energy stored in a large inductive device may cause non-polar type valves in a de-energized state to switch.
- When installing a breaker circuit to isolate the power, consider a valve with polarity (with polarity protection diode), or install a surge absorption diode across the output of the breaker.

3.10 How to wire DIN terminal wiring

Caution

- Use heavy duty cable with O.D. of Ø3.5 mm to Ø7 mm, otherwise it will not meet the IP65 (enclosure) standard (reference: 0.5 mm² 2 core and 3 core wires equivalent to JIS C 3306).
- Tighten the ground nut and set screw within the specified torque range.

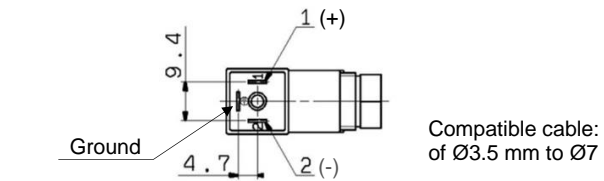
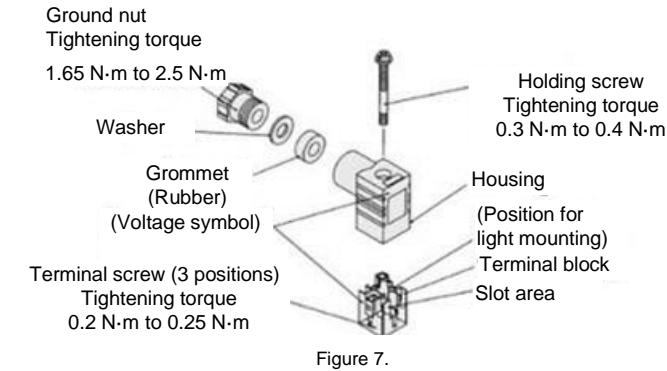

Figure 8. DIN type C

- Refer to catalogue for additional details.

3 Installation - continued

3.10.1 Circuit with indicator light for DIN terminal

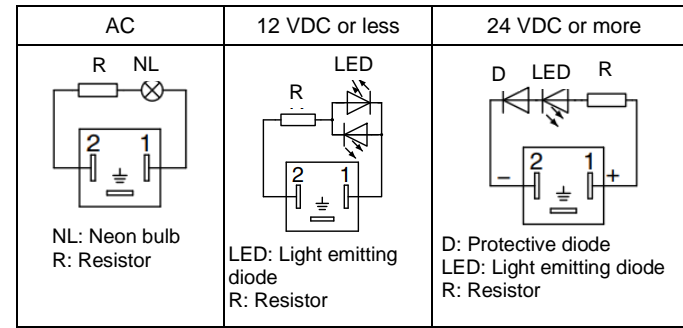

Figure 9.

3.10.2 Changing cable entry direction

Caution

- After separating terminal block and housing, the cable entry direction can be changed by attaching the housing in the desired direction (4 directions in 90 degree increments).
- In the case of valve with indicator light, avoid damaging the light with lead wire.

3.11 Extended periods of continuous energization

Warning

If a valve is energized continuously for a long period of time or is mounted in a control panel, the rise in temperature due to heat rise of the coil assembly may cause a decline in solenoid valve performance, reduce service life, or have adverse effects on peripheral equipment. If the valve is to be energized continuously for a long period of time, be sure to use the continuous duty type (VK33#E).

3.12 Manual override

Warning

Regardless of an electric signal for the valve, the manual override is used for switching the main valve. Connected actuator is started by manual operation. Only use the manual override after confirming that there is no

danger.

3.13 Mounting and removal of valves

- Tighten the valve mounting screw and bracket screw (if required) to the appropriate tightening torque of 0.6 N·m.
- Refer catalogue for details of mounting and removal of valves from manifold.

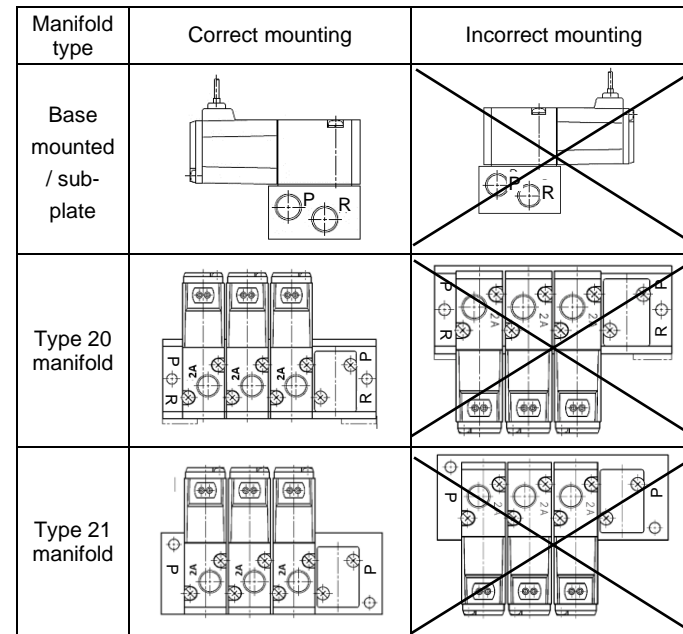

Figure 10.

3 Installation - continued

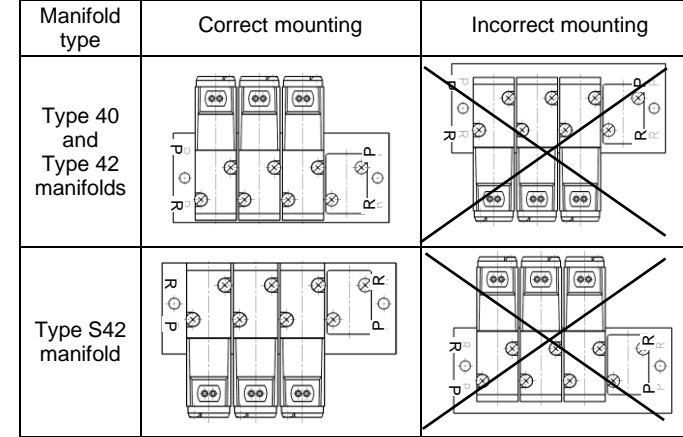

Figure 11.

4 How to Order

Refer to catalogue for 'How to order' or product drawing for special products.

5 Outline Dimensions (mm)

Refer to catalogue for outline dimensions.

6 Maintenance

6.1 General maintenance

Caution

- Not following proper maintenance procedures could cause the product to malfunction and lead to equipment damage.
- If handled improperly, compressed air can be dangerous.
- Maintenance of pneumatic systems should be performed only by qualified personnel.
- Before performing maintenance, turn off the power supply and be sure to cut off the supply pressure. Confirm that the air is released to atmosphere.
- After installation and maintenance, apply operating pressure and

power to the equipment and perform appropriate functional and leakage tests to make sure the equipment is installed correctly.

- If any electrical connections are disturbed during maintenance, ensure they are reconnected correctly and safety checks are carried out as required to ensure continued compliance with applicable national regulations.
- Do not make any modification to the product.
- Do not disassemble the product, unless required by installation or maintenance instructions.

7 Limitations of Use

Warning

The system designer should determine the effect of the possible failure modes of the product on the system.

7.1 Limited warranty and disclaimer/compliance requirements

Refer to Handling Precautions for SMC Products.

7.2 Breathing hole

Caution

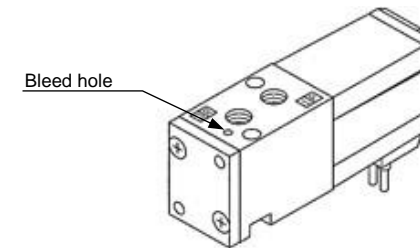

Figure 12.

There is a breathing hole on the bottom surface of the valve. Please note that liquid may enter or block the breathing hole, which may cause malfunction.

7 Limitations of Use - continued

7.3 Leakage voltage

Caution

Ensure that any leakage voltage caused by the leakage current when the switching element is OFF causes ≤2% (for DC coils) or ≤20% (for AC coils) of rated voltage across the valve.

7.4 Low temperature operation

Caution

Unless otherwise indicated in the specifications for each valve, operation is possible to -5°C, but appropriate measures should be taken to avoid solidification or freezing of drainage and moisture, etc.

7.5 Holding of pressure (including vacuum)

Warning

Since valves are subject to air leakage, they cannot be used for applications such as holding pressure (including vacuum) in a system.

7.6 Cannot be used as an emergency shut-off valve

Warning

This product is not designed for safety applications such as an emergency shut-off valve. If the valves are used in this type of system, other reliable safety assurance measures should be adopted.

7.7 Safety relays or PLC

Warning

If a safe output from a safety relay or PLC is used to operate this valve, ensure that any output test pulse duration is shorter than 1 ms to avoid the valve solenoid responding.

7.8 Spring returned spool valves

Warning

- The use of 2-position single valves with spring returned spools has to be carefully considered.
- The return of the valve spool into the de-energized position depends on the pilot pressure. If the pilot pressure drops below the specified operating pressure the position of the spool cannot be defined. The design of the system must take into account such behaviour.

- Additional measures might be necessary. For example, the installation of an additional air tank to maintain the pilot pressure.

Energy source status	Spool position
Air supply present, electricity cut	Spool returns to the de-energized position by spring force
Air supply cut before electricity cut	Spool returns to the de-energized position by spring force

Table 6.

8 Product Disposal

This product shall not be disposed of as municipal waste. Check your local regulations and guidelines to dispose this product correctly, in order to reduce the impact on human health and the environment.

9 Contacts

Refer to www.smcworld.com or www.smc.eu for your local distributor/importer.

SMC Corporation

URL : <https://www.smcworld.com> (Global) <https://www.smc.eu> (Europe)
 SMC Corporation, 4-14-1, Sotokanda, Chiyoda-ku, Tokyo 101-0021, Japan
 Specifications are subject to change without prior notice from the manufacturer.
 © 2021 SMC Corporation All Rights Reserved.
 Template DKP50047-F-085M