



ORIGINAL INSTRUCTIONS

Instruction Manual

Standard and Special VCH Valves and Manifolds

2/3 Port Pilot Operated Solenoid Valves

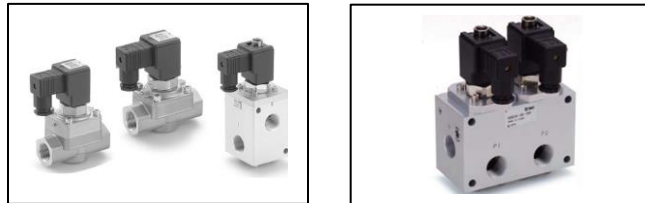

The intended use of these products is to supply and exhaust air for blowing applications.

1 Safety Instructions

These safety instructions are intended to prevent hazardous situations and/or equipment damage. These instructions indicate the level of potential hazard with the labels of "Caution," "Warning" or "Danger." They are all important notes for safety and must be followed in addition to International Standards (ISO/IEC) <sup>1)</sup>, and other safety regulations.

<sup>1)</sup> ISO 4414: Pneumatic fluid power - General rules relating to systems.  
 ISO 4413: Hydraulic fluid power - General rules relating to systems.  
 IEC 60204-1: Safety of machinery - Electrical equipment of machines. (Part 1: General requirements)  
 ISO 10218-1: Robots and robotic devices - Safety requirements for industrial robots - Part 1: Robots.

- Refer to product catalogue, Operation Manual and Handling Precautions for SMC Products for additional information.
- Keep this manual in a safe place for future reference.

<b>Caution</b>	Caution indicates a hazard with a low level of risk which, if not avoided, could result in minor or moderate injury.
<b>Warning</b>	Warning indicates a hazard with a medium level of risk which, if not avoided, could result in death or serious injury.
<b>Danger</b>	Danger indicates a hazard with a high level of risk which, if not avoided, will result in death or serious injury.

**Warning**

- Always ensure compliance with relevant safety laws and standards.
- All work must be carried out in a safe manner by a qualified person in compliance with applicable national regulations.
- If this equipment is used in a manner not specified by the manufacturer, the protection provided by the equipment may be impaired.

**Caution**

- The product is provided for use in manufacturing industries only. Do not use in residential premises.

2 Specifications

2.1 Standard internal pilot type valve specifications

Model	VCH41 (N.C.)	VCH42 (N.O.)	VCH410				
Valve construction	Internal pilot type poppet						
Ports	2		3				
Fluid	Air (Contact SMC for use with other fluids)						
Orifice [mm]	Ø16	Ø17.5	Ø18				
Port size	3/4	1	3/4	1	1/2	3/4	1
Max. operating pressure [MPa]	5						
Operating pressure differential [MPa] <sup>Note 1) 2)</sup>	0.5 to 5						
Ambient, storage and fluid temperature [°C]	5 to 80						
Flow Characteristics	C value [dm <sup>3</sup> /s.bar]	17	22	1-2 : 20	1-2 : 22		
				2-3 : 22	2-3 : 24		
Effective area [mm <sup>2</sup> ]	85	110	1-2 : 100	1-2 : 110			
			2-3 : 110	2-3 : 120			

2 Specifications – continued

Response time	Refer to catalogue		
Duty cycle	Contact SMC		
Maximum operating frequency	Contact SMC		
Minimum operating frequency	1 cycle / 30 days		
Impact/vibration resistance [m/s <sup>2</sup> ] <sup>Note 3) 4)</sup>	300 / 100		
Enclosure	IP65 equivalent		
Body material	Brass	Aluminium + hard anodized	
Main seal material	Polyurethane elastomer		
Mounting orientation	Restricted		
Weight [kg]	1.67	1.9	1.83 (G1/2, G3/4), 2.11 (G1)

Table 1.

Note 1) Be aware that if the pressure differential is above the minimum operating pressure differential when the valve is closed, the pressure differential may fall below the minimum operating pressure differential when the valve opens, depending on the power of the supply source (pumps, compressors, etc.) or the type of pipe restrictions.

Note 2) When used as a selector valve (pressurising 1,3 port), the pressure in the port should be within the range of the port 1 pressure with P1 ≥ 2 x P3 and a relief regulator is needed in the low pressure line.

Note 3) **Impact resistance:** No malfunction resulted in an impact test using a drop impact tester. The test was performed one time each in the axial and right angle directions of the main valve and armature, for both energized and de-energized states. (Values quoted are for a new valve).

**Vibration resistance:** No malfunction resulted in 8.3 to 2000 Hz, a one-sweep test performed in the axial and right angle directions of the main valve and armature for both energized and de-energized states. (Values quoted are for a new valve).

Note 4) Vibration resistance is 50 m/s<sup>2</sup> when light/surge voltage suppressor is attached.

2.2 Solenoid specifications

Coil rated voltage	VDC	12, 24
	VAC	100, 110, 200, 220 (50/60 Hz)
Allowable voltage fluctuation	±10% of rated voltage <sup>Note 1)</sup>	
Electrical entry	DIN connector	
Coil insulation type	Class B	
Power consumption	5 W (DC), 13 VA (AC)	

Table 2.

Note 1) Valve state is not defined if electrical input is outside the specified operating ranges.

Note 2) No inrush voltages are generated in the AC solenoid because a full wave rectifier is used.

Note 3) A surge voltage suppressor is integrated inside the coil as a standard feature.

2.3 External pilot type valve specifications

Refer to drawings for external pilot type valve specifications.

2.4 Manifold specifications

Refer to drawings for manifold specifications.

2.5 Pneumatic symbols

Refer to catalogue or drawing for pneumatic symbols.

2.6 Special specifications

**Caution**

Special products (-X) might have specifications different from those shown in this section. Contact SMC for specific drawings.

3 Installation

3.1 Installation

**Warning**

- Do not install the product unless the safety instructions have been read and understood.

3.2 Environment

**Warning**

- Do not use in an environment where corrosive gases, chemicals, salt water or steam are present.

3 Installation – continued

- Do not use in an explosive atmosphere.
- Do not expose to direct sunlight. Use a suitable protective cover.
- Do not install in a location subject to vibration or impact in excess of the product's specifications.
- Do not mount in a location exposed to radiant heat that would result in temperatures in excess of the product's specifications.
- Products compliant with IP65 enclosures are protected against dust and water, however, these products cannot be used in water.
- Products compliant with IP65 enclosures satisfy the specifications by mounting each product properly. Be sure to read the Specific Product Precautions for each product.
- Do not use in a high humidity environment where condensation may occur.
- Contact SMC for altitude limitations.

3.3 Piping

**Caution**

- Before connecting piping make sure to clean up chips, cutting oil, dust etc.
- When installing piping or fittings, ensure sealant material does not enter inside the port. When using seal tape, leave 1.5 to 2 threads exposed on the end of the pipe/fitting.
- If using tube piping, secure the product to a permanent fixture. Do not suspend it by the tubing.
- Tighten fittings to the specified tightening torque.

Connection thread (Rc, G)	Appropriate Tightening Torque [N·m]
1/8	7 to 9
1/2	28 to 30
3/4	
1	36 to 38
1 1/4	40 to 42
1 1/2	48 to 50
2"	

Table 3.

3.4 Lubrication

**Caution**

- SMC products have been lubricated for life at manufacture, and do not

require lubrication in service.  
 • For 3 port valves NSF-H1 grease is standard.

3.5 Air supply

**Warning**

- Use clean air. If the compressed air supply includes chemicals, synthetic materials (including organic solvents), salinity, corrosive gas etc., it can lead to damage or malfunction.

**Caution**

- Install an air filter upstream of the valve. Select an air filter with a filtration size of 5 µm or smaller.

3.6 Electrical connection

- Use electrical wire with a cross sectional area of 0.5 to 1.25 mm<sup>2</sup> for wiring. Furthermore, do not allow excessive force to be applied to the wires.
- Use electrical circuits which do not generate chattering in their contacts.
- Use voltage which is within ±10% of the rated voltage. In cases with a DC power supply where importance is placed on responsiveness, stay within ±5% of the rated value. The voltage drop is the value in the lead wire section connecting the coil.
- When surge from the solenoid affects the electrical circuitry, install a surge absorber, etc., in parallel with the solenoid.

3.6.1 DIN connector

3.6.1.1 Standard products

**Caution**

- Use compatible heavy duty cords with cable O.D. of Ø6 to 12 mm.
- Use the tightening torques below for each section.
- Make connections to the power supply according to figures 1 & 2.

3 Installation – continued

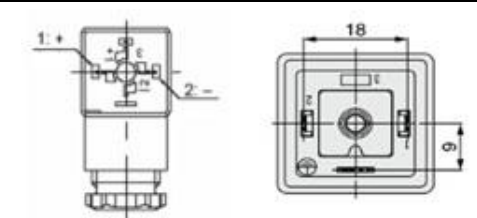

Figure 1. DIN Type A

Terminal No.	1	2
DIN terminal	+	-

Table 4. For internal pilot type valves

- DIN terminal corresponds to the Form A DIN connector with an 18 mm terminal pitch, which complies with EN175301-803B.

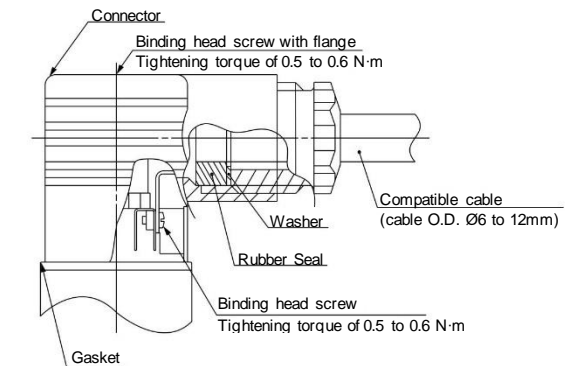

Figure 2. For internal pilot type valves

- If using cable with outer diameter of Ø9-12 mm, remove inner part of rubber seal before use.

3.6.1.2 Special external pilot type products

**Caution**

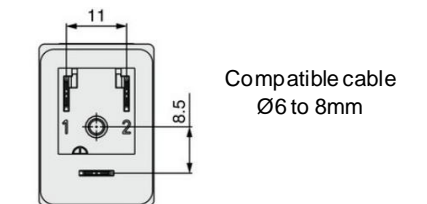

Figure 3. DIN Type B

Terminal No.	1	2
DIN terminal	+	-

Table 5. For SF4 external pilot type valves

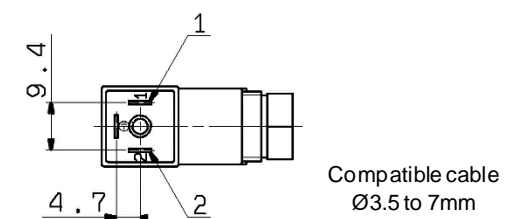

Figure 4. DIN Type C

Terminal No.	1	2
DIN terminal	+	-

Table 6. For VQZ and VK external pilot type valves

### 3 Installation – continued

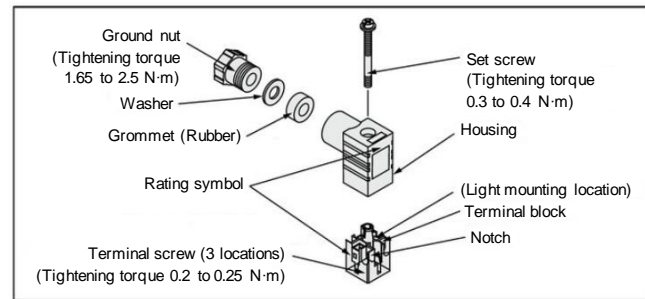

Figure 5. DIN exploded view for SF4, VQZ and VK pilot valves

#### 3.6.2 Electrical circuit

##### 3.6.2.1 Standard products

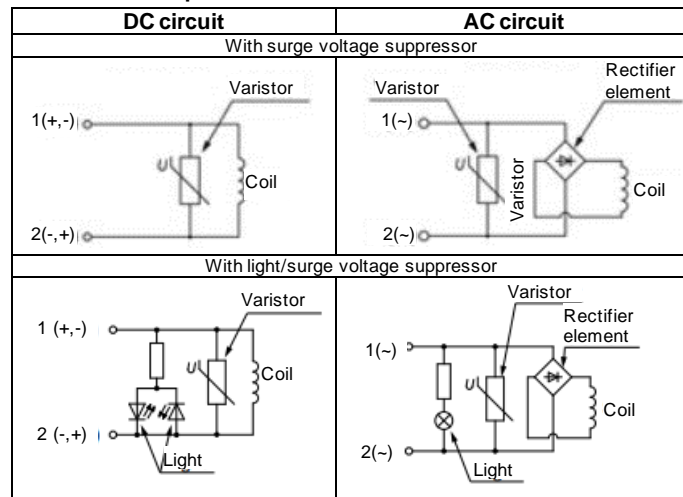

Figure 6. Electrical wiring diagrams for AC and DC solenoids

##### 3.6.2.2 Special products (Refer to drawings for more details)

In the case of valves without surge suppressor, the machine designer

shall add suppression as close as possible to the valve.

##### • VQZ pilot valve

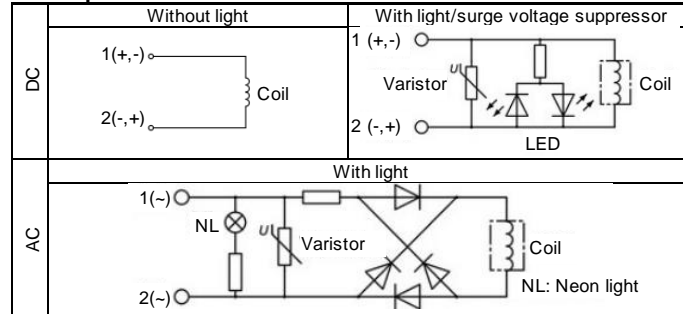

Table 7.

##### • VK pilot valve

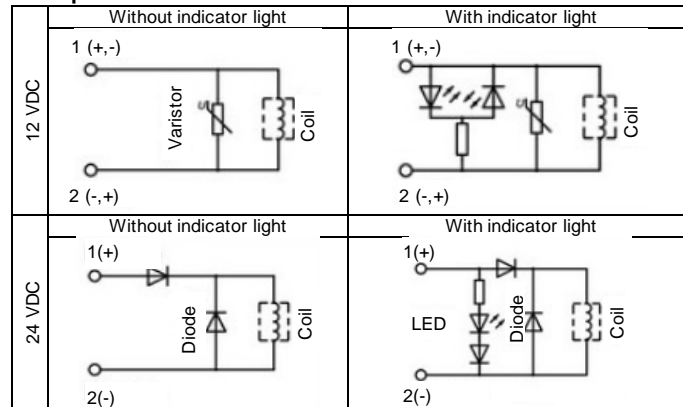

Table 8.

### 3 Installation – continued

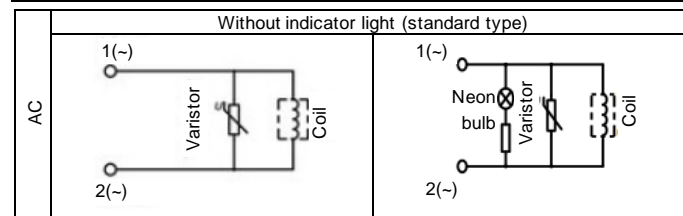

Table 9.

##### • SF4 pilot valve

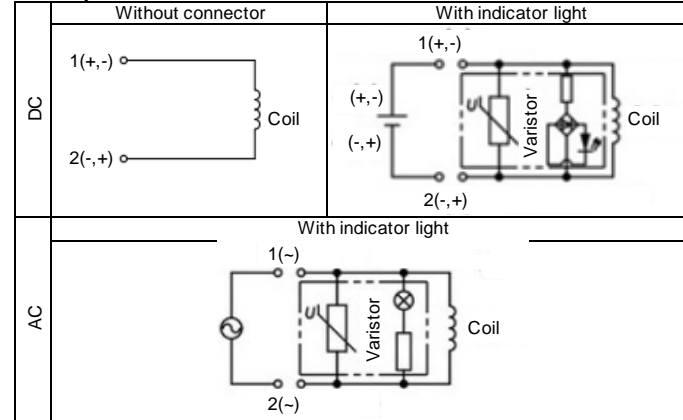

Table 10.

#### 3.7 Residual voltage

**Caution**

- If a varistor or diode surge voltage suppressor is used, the suppressor arrests the back EMF voltage from the coil to approximately 1 V.
- Ensure the transient voltage is within the specification of the host controller.
- Valve response time is dependent on surge suppression method selected.

#### 3.8 Countermeasure for surge voltage

**Caution**

- When using special products, ensure measures are taken to mitigate effects from surge voltages.
- At times of sudden interruption of the power supply, the energy stored in a large inductive device may cause non-polar type valves in a de-energised state to switch.
- When installing a breaker circuit to isolate the power, consider a valve with polarity (with polarity protection diode), or install a surge absorption diode across the output of the breaker.

#### 3.9 Mounting

**Warning**

- Ensure sufficient space for maintenance activities.
- Avoid sources of vibration or adjust the distance from the body to a minimum length so that resonance will not occur.
- Do not apply external force to the coil section: Be sure to apply the wrench to the external part of the piping connection. (Hexagonal parts or width across flats). Also, use caution when mounting a silencer or piping to the VCH410 series 3-port solenoid valve because the top (G1/4) is a pilot exhaust port.
- For internal pilot type, do not install with the coil downwards. If a valve is mounted with the coil positioned downwards, foreign objects in the fluid will adhere to the core/armature leading to a malfunction.
- After installation, apply operating pressure and power to the equipment and perform appropriate functional and leakage tests to make sure the equipment is installed correctly. If leakage increases or equipment does not operate properly, stop operation.
- For special products, check their weight before handling.

#### 3.10 Flow controller

**Caution**

- For special products fitted with flow controller, it controls the flow rate supplied to P1.
- Note that:
- Flow rate may change if not locked.
  - If the screw is overtightened, the thread may be damaged. Recommended tightening torque 0.8 to 1 N·m.

### 4 How to Order

Refer to catalogue for 'How to order' or to product drawing for special products.

### 5 Outline Dimensions (mm)

Refer to catalogue for 'Outline Dimensions' or to product drawing for special products.

### 6 Maintenance

#### 6.1 General Maintenance

**Caution**

- Not following proper maintenance procedures could cause the product to malfunction and lead to equipment damage.
- If handled improperly, compressed air can be dangerous.
- Maintenance of pneumatic systems should be performed only by qualified personnel.
- Before performing maintenance, turn off the power supply and be sure to cut off the supply pressure. Confirm that the air is released to atmosphere.
- After installation and maintenance, apply operating pressure and power to the equipment and perform appropriate functional and leakage tests to make sure the equipment is installed correctly.
- If any electrical connections are disturbed during maintenance, ensure they are reconnected correctly and safety checks are carried out as required to ensure continued compliance with applicable national regulations.
- Do not make any modification to the product.
- Do not disassemble the product, unless required by installation or maintenance instructions.
- Exhaust drainage from the air filters periodically.
- In the case of long term storage after use, thoroughly remove all moisture to prevent rust and deterioration of rubber materials, etc.

#### 6.2 Maintainable parts

**Warning**

- Under no circumstances attempt to change the pilot valve assembly as this is an integral part of the valve.
- There are no replaceable parts on these products.

#### 6.3 Storage

**Caution**

In the case of long term storage, thoroughly remove all moisture to prevent rust and deterioration of rubber materials, etc.

### 7 Limitations of Use

**Warning**

The system designer should determine the effect of the possible failure modes of the product on the system.

#### 7.1 Limited warranty and Disclaimer/Compliance Requirements

Refer to Handling Precautions for SMC Products.

**Warning**

#### 7.2 Cannot be used as an emergency shut-off valve

This product is not designed for safety applications such as an emergency shut-off valve. If the valves are used in this type of system, other reliable safety assurance measures should be adopted.

#### 7.3 Closed liquid circuit

In a closed circuit, when liquid is static, pressure could rise due to changes in temperature. This pressure rise could cause malfunction and damage to components such as valves. To prevent this, install a relief valve in the system.

#### 7.4 Impact by rapid pressure fluctuation

When an impact caused by the rapid pressure fluctuation, such as water hammer etc., is applied, the solenoid valve may be damaged. Install water hammer relief equipment (accumulator, etc.), or use a SMC water hammer relief valve (e.g. VXR series).

#### 7.5 Extended periods of continuous energization

- The solenoid coil will generate heat when continuously energized, so avoid installing in an enclosed space. Install in a well-ventilated area.
- Do not touch the coil while it is being energized or immediately after energization.

### 7 Limitations of Use – continued

#### 7.6 Pilot EXH

If the pilot valve leaks and the pilot EXH is blocked, the body may operate (OFF to ON).

#### 7.7 Holding of pressure

Since valves are subject to air leakage, they cannot be used for applications such as holding pressure (including vacuum) in a system.

#### 7.8 Low frequency operation

- Switch valves at least once every 30 days to prevent malfunction.
- Conduct a regular inspection once every half a year.

#### 7.9 Safety relays or PLC

If a safe output from a safety relay or PLC is used to operate this valve, ensure that any output test pulse duration is shorter than 1 ms to avoid the valve solenoid responding.

#### 7.10 Use caution regarding back pressure

- When port 3 (EXH) of a 3 port solenoid valve (VCH400 series) is excessively throttled or used as a selector valve (pressurizing 1, 3 port), the pressure in the port should be within a range of half the pressure in port 1 (port 1 pressure  $\geq$  twice port 3 pressure). Using the valve outside the specifications above may cause a switching failure or unstable operation.
- In the case of a 3-port solenoid valve, when the valve is being switched, a high-pressure air will be introduced into the lower pressure side. Therefore, when using this product as a selector valve for switching a high and medium pressure, a relief type regulator (VCHR series) must be used for the medium pressure side.
- Use caution when valves are used on a manifold, because an actuator may malfunction due to back-pressure.

#### 7.11 Use caution regarding exhaust port freezing.

If a high-pressure air (more than 1.0 MPa) is quickly exhausted, there may be an occurrence in which the valve will not switch properly or the service life will substantially decrease due to condensation or freezing caused by the substantial temperature change. When condensation or freezing occurs, take measures such as using a freeze-reducing silencer (VCHNF series), etc.

#### 7.12 Breathing hole

**Caution**

For external pilot valves, there is a breathing hole in the piston moving part of the product. Please note that liquid may enter or block the breathing hole, which may cause malfunction.

**Warning**

In case of leakage from pilot valve and clogging of pilot EXH, the main valve may switch from OFF to ON.

#### 7.13 Leakage voltage

**Caution**

Ensure that any leakage voltage caused by the leakage current when the switching element is OFF causes <2% of the rated voltage across the valve for DC coils and <10% for AC coils.

### 8 Product Disposal

This product shall not be disposed of as municipal waste. Check your local regulations and guidelines to dispose this product correctly, in order to reduce the impact on human health and the environment.

### 9 Contacts

Refer to [www.smcworld.com](http://www.smcworld.com) or [www.smc.eu](http://www.smc.eu) for your local distributor/importer.

## SMC Corporation

URL: <https://www.smcworld.com> (Global) <https://www.smc.eu> (Europe)  
 SMC Corporation, 4-14-1, Sotokanda, Chiyoda-ku, Tokyo 101-0021, Japan  
 Specifications are subject to change without prior notice from the manufacturer.  
 © 2021 SMC Corporation All Rights Reserved.  
 Template DKP50047-F-085M