



ORIGINAL INSTRUCTIONS



Refer to Declaration of Conformity for relevant Directives

Instruction Manual

Mechanically Jointed Rodless Cylinder

55-MY1B-Z Series

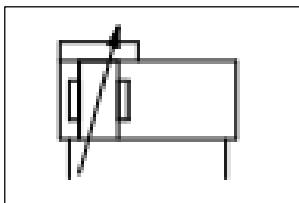
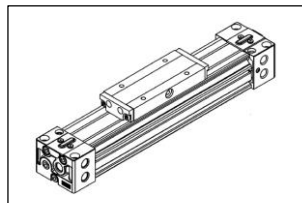

CE Ex II 2G	Ex h IIC T6/T5 Gb	+5°C ≤ Ta ≤ +60°C
-------------	-------------------	-------------------

ATEX Marking Description:

Ex	Specific Marking for Explosion Protection
II	Equipment Group
2	Equipment Category
G	Environment (Gas)
Ex h	General Protection Level Symbols
IIC	Gas Sub-Division
T	Temp. Classification
Gb	Equipment Protection Level
X	Special Conditions of Use
Ta	Ambient Temperature Range

The intended use of this ATEX Category 2 actuator is to convert the potential energy provided by compressed air into a force which causes mechanical linear motion.

Certificate Number:	SMC19.0044 X
---------------------	--------------

Note 1: The X at the end of the certificate number represents that this product is

subject to "Special Conditions of Use", please see Section 2.3.

1 Safety Instructions

These safety instructions are intended to prevent hazardous situations and/or equipment damage. These instructions indicate the level of potential hazard with the labels of "Caution," "Warning" or "Danger." They are all important notes for safety and must be followed in addition to International Standards (ISO/IEC¹⁾, and other safety regulations.

- ¹⁾ ISO 4414: Pneumatic fluid power - General rules relating to systems.
- ISO 4413: Hydraulic fluid power - General rules relating to systems.
- IEC 60204-1: Safety of machinery - Electrical equipment of machines. (Part 1: General requirements)
- ISO 10218-1: Manipulating industrial robots -Safety, etc.

- Refer to product catalogue, Operation Manual and Handling Precautions for SMC Products for additional information.
- Keep this manual in a safe place for future reference.

	Caution	Caution indicates a hazard with a low level of risk which, if not avoided, could result in minor or moderate injury.
	Warning	Warning indicates a hazard with a medium level of risk which, if not avoided, could result in death or serious injury.
	Danger	Danger indicates a hazard with a high level of risk which, if not avoided, will result in death or serious injury.

Warning

- Always ensure compliance with relevant safety laws and standards.
- All work must be carried out in a safe manner by a qualified person in compliance with applicable national regulations.

2 Specifications

This product is certified to ATEX Category 2G and therefore is suitable for use in Zones 1 and 2 only.

2.1 Product Specifications:

Refer to the operation manual for this product;

2.1.1 Standard Product:

Fluid	Air	
Max. Operating Pressure	0.8 MPa	
Min. Operating Pressure	0.1 MPa	
Ambient & Fluid Temperature	+5°C to +60°C	
Lubrication	Not Required	
Operating Piston Speed	100 to 1000 mm/s	
Cushion	Air Cushion	
Allowable Kinetic Energy	Ø25	1.7 J
	Ø32	3.4 J
	Ø40	6.2 J

2.2 Production Batch Code:

The batch code printed on the label indicates the month and the year of production as per the following table;

		Production Batch Codes											
Year	Month	2017	2018	2019	...	2021	2022	2023	...	2025	2026	2027	...
Jan	O	Vo	Wo	Xo	...	Zo	Ao	Bo	...	Co	Do	EO	...
Feb	P	VP	WP	XP	...	ZP	AP	BP	...	CP	DP	EP	...
Mar	Q	VQ	WQ	XQ	...	ZQ	AQ	BQ	...	CQ	DQ	EQ	...
Apr	R	VR	WR	XR	...	ZR	AR	BR	...	CR	DR	ER	...
May	S	VS	WS	XS	...	ZS	AS	BS	...	CS	DS	ES	...
Jun	T	VT	WT	XT	...	ZT	AT	BT	...	CT	DT	ET	...
Jul	U	VU	WU	XU	...	ZU	AU	BU	...	CU	DU	EU	...
Aug	V	VV	WV	XV	...	ZV	AV	BV	...	CV	DV	EV	...
Sep	W	VW	WW	XW	...	ZW	AW	BW	...	CW	DW	EW	...
Oct	X	VX	WX	XX	...	ZX	AX	BX	...	CX	DX	EX	...
Nov	Y	Vy	Wy	Xy	...	Zy	Ay	By	...	Cy	Dy	Ey	...
Dec	Z	VZ	WZ	XZ	...	ZZ	AZ	BZ	...	CZ	DZ	EZ	...

2.3 Special Conditions of Use:

- Products are suitable for sub-divisions IIC.
- Products are suitable for Zones 1 & 2 only.

2.3.1 Temperature Marking:

2.3.1.1 Standard Product:

- In the normal ambient temperature range (+5°C to +40°C) the product is rated to temperature class T6.
- In the special ambient temperature range (+40°C to +60°C) the product is rated to temperature class T5.

2.3.2 Static:

- Danger of electrostatic discharge.

3 Installation

3.1 Installation

Warning

- Do not install the product unless the safety instructions have been read and understood.
- Do not twist or bend the cylinder, or mount the product when subject to tension.
- Do not use in an application where the product is stopped mid-stroke, via an external stop.
- Do not use where cylinders are being synchronised to move a single load.
- In order to install the product, use one of the brackets available found in the standard product catalogue;

Accessories	Sketch	Series
-------------	--------	--------

Side Support A		MY-S*A
Side Support B		MY-S*B

Note: See the product catalogue for the exact code to order which relates to the bore size of your product.

- When replacing the side supports, use the hexagonal socket head cap screws of the following sizes, and the hexagon wrenches shown below.

Bore [mm]	Cap Screw Size		Width Across Flats [mm]	
	Side Support A	Side Support B	Side Support A	Side Support B
Ø25	M5	M6	4	5
Ø32	M6	M8	5	6
Ø40	M8	M10	6	8

3.2 Environment

Warning

- Do not use in an environment where corrosive gases, chemicals, water, salt water or steam are present.
- Do not use in an explosive atmosphere except within the specified rating.
- Do not expose to direct sunlight. Use a suitable protective cover.
- Do not install in a location subject to vibration or impact in excess of the product's specifications.

- Do not use in a place subject to heavy vibration and/or shock.

- Do not use in wet environments, where water can remove the presence of the lubrication.

- Do not use in case of heavy dusty environments where dust can penetrate into the cylinder and dry the grease.

- Do not allow dust layers to build up on the cylinder surface and insulate the product.

3.3 Piping

Caution

- Before connecting piping make sure to clean up chips, cutting oil, dust etc.
- When installing piping or fittings, ensure sealant material does not enter inside the port. When using seal tape, leave 1 thread exposed on the end of the pipe/fitting.
- Tighten fittings to the specified tightening torque.

Bore [mm]	Port Size	Bore [mm]	Port Size
Ø25-Ø32	1/8	Ø40	1/4

3.4 Lubrication

Caution

- SMC products have been lubricated for life at manufacture, and do not require lubrication in service.
- If a lubricant is used in the system, refer to catalogue for details.

3.5 Basic Circuit

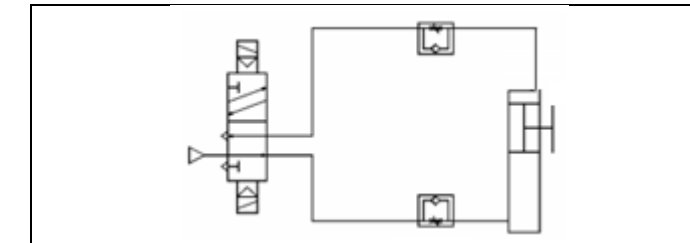

- Plugging one of the ports on the actuator is considered a non-intended use, and could relate to an increase in maximum surface temperature above what the product specification declares.

3.6 Electrical Connection

- The product should be grounded by the piston rod and the body in order to create an electrically conductive path to the system/application.
- Ground the product in accordance with applicable regulations.
- Do not pass an electrical current through the product.

4 Settings

4.1 Air Cushion adjustment

- For air-cushion adjustment, tighten or loosen the cushion valve using a hexagon socket wrench or a flat head screwdriver (excluding ø10).

Warning

- Do not operate the cushion valve in the fully closed or fully opened state.

Using it in the fully closed state will cause the cushion seal to be damaged. Using it in the fully opened state will cause the piston assembly or the cover to be damaged.

- Be certain to activate the air cushion at the stroke end. When the cylinder is used with the cushion valve in a fully open position, a suitable external device should be installed to absorb all of the kinetic energy of the mechanism, of which the actuator is part, before reaching each end of stroke. If this is not done, the piston assembly will be damaged.

Bore [mm]	Cushion Valve Head	Width across flats [mm]
Ø25	Hexagon Socket	1.5
Ø32 - Ø40		2.5

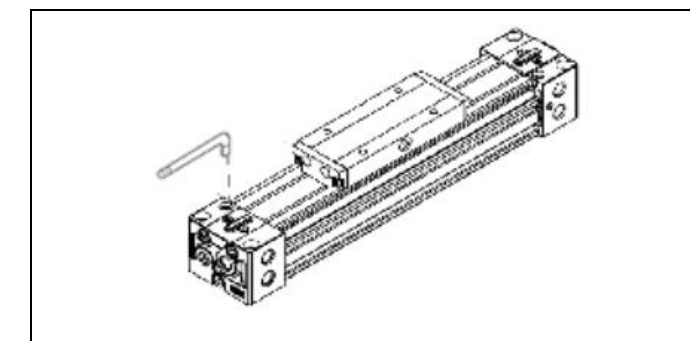

5 How to Order

Refer to the standard product catalogue for 'How to Order'.

6 Outline Dimensions (mm)

Refer to the standard product catalogue for general dimensions.

7 Maintenance

7.1 General Maintenance

Caution

- Not following proper maintenance procedures could cause the product to malfunction and lead to equipment damage.
- If handled improperly, compressed air can be dangerous.
- Maintenance of pneumatic systems should be performed only by qualified personnel.
- Before performing maintenance, turn off the power supply and be sure to cut off the supply pressure. Confirm that the air is released to atmosphere.

- After installation and maintenance, apply operating pressure and power to the equipment and perform appropriate functional and leakage tests to make sure the equipment is installed correctly.
- If any electrical connections are disturbed during maintenance, ensure they are reconnected correctly and safety checks are carried out as required to ensure continued compliance with applicable national regulations.
- Do not make any modification to the product.
- Do not disassemble the product, unless required by installation or maintenance instructions.
- Do not use a product which looks or contains damage, this will invalidate the certification. If damage is seen, please replace the product immediately.
- Periodically check the product for any damage or rust appearing. This could result in an increase in friction and lead to dangerous conditions. Replace the whole actuator if any of these conditions appear.
- Replace the product, when air leakage is above the allowable value given in the table below;

	Allowable Leakage
Leakage at 0.1 MPa	300 cm ³ / min (ANR)
Leakage at 0.8 MPa	425 cm ³ / min (ANR)

7.2 Replacement of Dust Seal Band

Warning

- The dust seal band is the only customer replaceable part.
- If other parts are deemed to have failed please replace the product.

Use only original SMC dust seal bands, given in the table below.

Bore size [mm]	Replacement part no.	Standard length
Ø25	MY1B25-16B-stroke	Stroke+184
Ø32	MY1B32-16B-stroke	Stroke+242
Ø40	MY1B40-16B-stroke	Stroke+286

7.3 Disassembly procedure

- Disassemble the cylinder, remove the old grease and place all the parts on a clean cloth in a clean environment. The following flat head screwdriver or hexagon socket wrench shall be used to loosen the set screws:

Bore size [mm]	Head	Width across flats [mm]
Ø25 ~ Ø40	Hexagon socket	1.5

- The following screwdriver or hexagon socket wrenches shall be used to loosen the end cover screws.

Bore size [mm]	Head	Width across recess and across flats [mm]
Ø25 ~ Ø40	Hexagon socket	2.5

- Loosen the two thin head screws at each end.
- Remove the end cover by removing two hexagon socket button head screws for fixing on the end cover (at both sides of the slider).
- Remove the second end cover the same way.
- Remove top cover.
- Pull out the dust band in this condition.

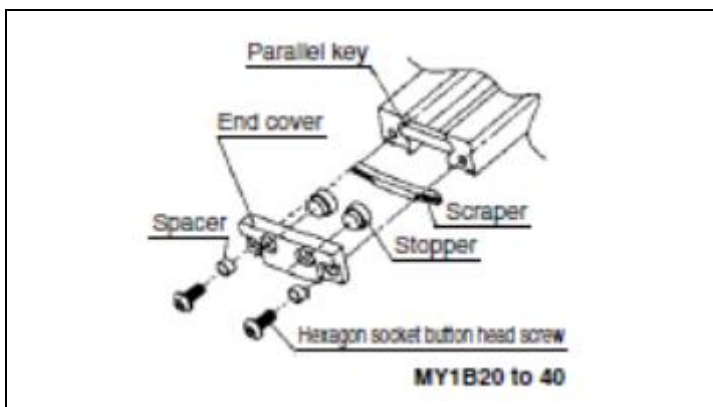

7.4 Reassembly procedure

- Fully grease the replacement dust seal band.
- Put the replacement dust seal band in the slider.

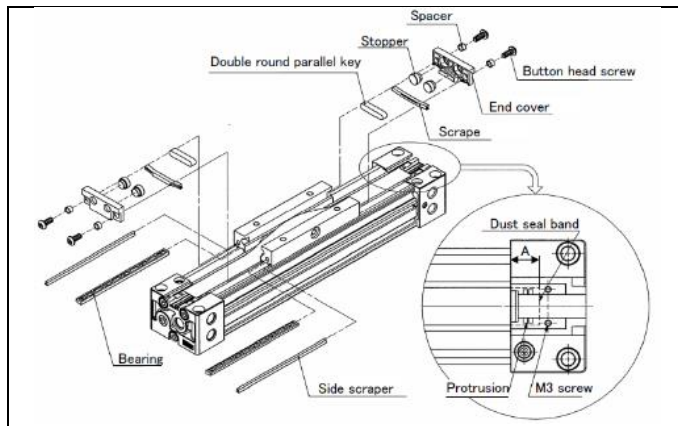

- Install the dust seal band by placing its edge in the middle between the protrusions and the M3 screws on the head cover surface.
- Install the double round parallel key and mount the end cover, spacers and stoppers with the fixing bolts.
- Make sure that the clearance between the lower part of the end cover and the upper surface of the cylinder tube shall be approximately 1mm when fixing the end cover.

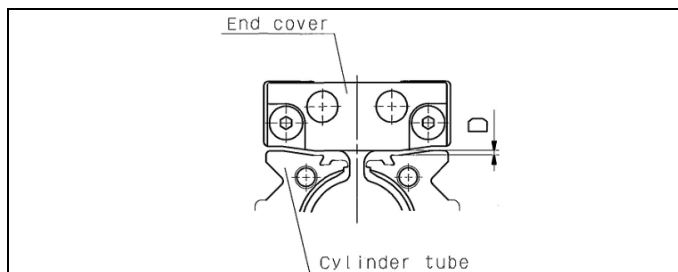

- For the size and torque of the equivalent hexagon socket button head screw see below;

Bore size [mm]	Size	Torque [N.m]
Ø25, Ø32, Ø40	M4	0.7

- Fix one side dust seal band, belt clamp and head plate with the thin head screws.

Bore size [mm]	Size	Torque [N.m]
Ø25, Ø32, Ø40	M3	0.63

- After fixing the one side dust seal band, operate the cylinder from the retracted end to the extended end several times (3 to 4 time) to confirm that the dust seal band has no sag.
- Fix the other side dust seal band, belt clamp and head plate with the thin head screws.
- Install the top cover and operate the cylinder from the retracted end to the extended end several times by hand. If the dust seal band is not lifted up or does not have sag, the reassembly is completed.

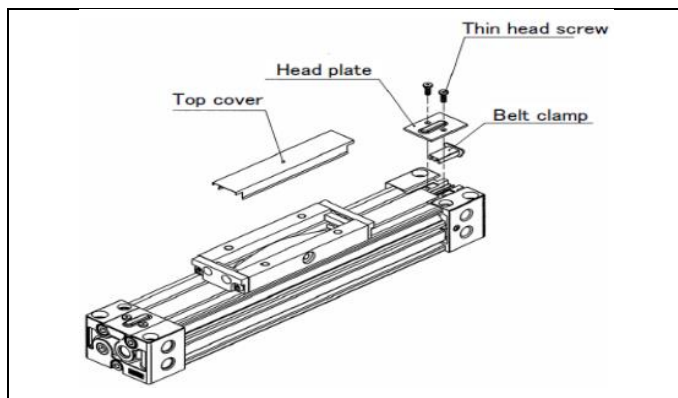

- Check for smooth movement of the cylinder, and confirm there is no air leakage.

7.5 Lubrication procedure

Lubricate the parts using the following SMC grease packs:

Product	Grease pack number	Weight (g)
Standard	GR-S-010	10
	GR-S-020	20

Apply lubricant to:

- Dust seal band inner and outer surface
- scrapers
- bearings
- side scrapers
- tube top surface

8 Limitations of Use

8.1 Limited warranty and Disclaimer/Compliance Requirements

Refer to Handling Precautions for SMC Products located on www.smworld.com.

8.2 Obligations of the end-user

- Ensure the product is used within the specification outlined.
- Ensure that the maintenance periods are suitable for the application.
- Ensure any cleaning processes to remove dust layers are made with the atmosphere in mind (e.g. using a damp cloth to avoid static build up).
- Ensure that the application does not introduce additional hazards by mounting, loading, impacts or other methods.
- Ensure that there is sufficient ventilation and air circulation around the product.
- If the product is subject to direct heat sources in the application, they should be shielded so that the actuator temperature stays within the stated operating range.

Caution

- SMC products are not intended for use as instruments for legal

metrology.

Measurement instruments that SMC manufactures or sells have not been qualified by type approval tests relevant to the metrology (measurement) laws of each country.

Danger

- Do not exceed any of the specifications listed in Section 2 of this document as this will be deemed improper use.
- Air equipment has an air leakage during operation within certain limits. Do not use this equipment when the air itself introduces additional hazards and could lead to an explosion.
- Use only ATEX certified auto switches. These should be ordered separately.
- Do not use this product in the presence of strong magnetic fields that could generate a surface temperature higher than the product specification.
- Avoid applications where the piston rod end and the adjoining part in the application can create a possible ignition source.
- Do not install or use these actuators where there is the possibility for the piston rod to impact foreign objects.
- In the event of damage or failure of any parts located in the vicinity where this product has been installed, it is the responsibility of the user to determine whether or not this has compromised the safety and condition of this product and/or the application.
- External impact on the cylinder body could result in a spark and/or cylinder damage. Avoid any application where foreign objects can hit or impact the cylinder. In such situations the application should install a suitable guard to prevent this occurrence.
- Do not use this equipment where vibration could lead to failure.

9 Contacts

Refer to Declaration of Conformity and www.smworld.com for contacts.

SMC Corporation

URL : [http:// www.smworld.com](http://www.smworld.com) (Global) [http:// www.smce.com](http://www.smce.com) (Europe)
 SMC Corporation, Akihabara UDX15F, 4-14-1, Sotokanda, Chiyoda-ku, Tokyo 101 0021
 Specifications are subject to change without prior notice from the manufacturer.
 © 2018 SMC Corporation All Rights Reserved.
 Template DKP50047-F-085H