

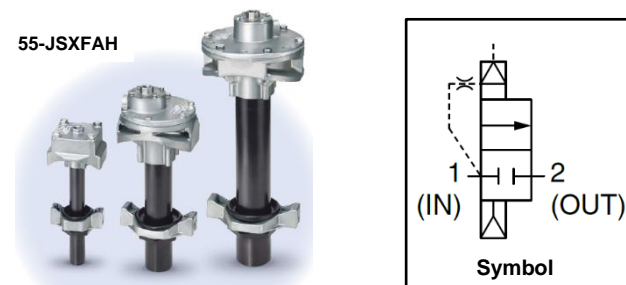

ORIGINAL INSTRUCTIONS

Instruction Manual
Pulse Valve for Dust Collector
55-JSXFA Series

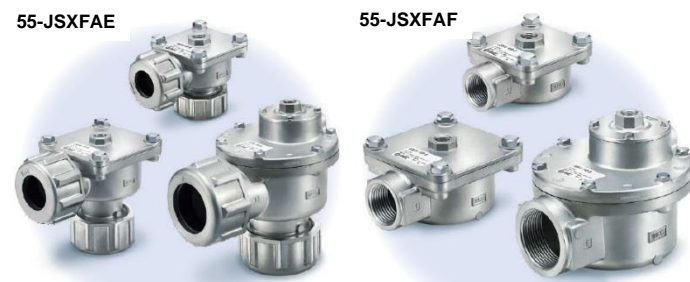

Ex classification: II 2 G Ex h IIB T6 Gb -40°C ≤ Ta ≤ +60°C
II 2 D Ex h IIB T72°C Db
Certificate reference: SMC 19.0013 X
For special conditions of use see section 1.2.

The intended use of this product is to provide a pulse of air in dust collector and similar systems.

1 Safety Instructions

1.1 General safety
These safety instructions are intended to prevent hazardous situations and/or equipment damage. These instructions indicate the level of potential hazard with the labels of "Caution," "Warning" or "Danger." They are all important notes for safety and must be followed in addition to International Standards (ISO/IEC^{*)}, and other safety regulations.

^{*)} ISO 4414: Pneumatic fluid power - General rules relating to systems.
ISO 4413: Hydraulic fluid power - General rules relating to systems.
IEC 60204-1: Safety of machinery - Electrical equipment of machines. (Part 1: General requirements)
ISO 10218-1: Robots and robotic devices - Safety requirements for industrial robots - Part 1: Robots.

- Refer to product catalogue, Operation Manual and Handling Precautions for SMC Products for additional information.
- Keep this manual in a safe place for future reference.

	Caution	Caution indicates a hazard with a low level of risk which, if not avoided, could result in minor or moderate injury.
	Warning	Warning indicates a hazard with a medium level of risk which, if not avoided, could result in death or serious injury.
	Danger	Danger indicates a hazard with a high level of risk which, if not avoided, will result in death or serious injury.

Warning

- Always ensure compliance with relevant safety laws and standards.
- All work must be carried out in a safe manner by a qualified person in compliance with applicable national regulations.

1.2 Special conditions of use

Warning

- To avoid the build-up of electrostatic charge, do not mount in areas subject to electrostatic charging mechanisms and clean only with a damp cloth and allow to dry naturally.

2 Specifications

2.1 Valve specifications

Specifications	Port size			
	06	10	14	20 ^{Note 1)}
Orifice diameter [mm]	32	40	50 45 ^{Note 1)}	55
Port size [Rc, NPT, G]	3/4	1	1 1/2	2
Fluid	Air			
Air filtration [µm]	5 (or less)			
Minimum operating pressure differential [MPa]	0.1			
Maximum operating pressure differential [MPa]	0.9			
Max. system pressure [MPa]	0.9			
Fluid temperature [°C]	-40 ^{Note 2)} to 60			
Ambient temperature [°C]	-40 to 60			
Flow rate	Refer to catalogue			
Response time	Refer to catalogue			
Operating environment	Indoor/Outdoor ^{Note 3)}			

Note 1) JSXFAH type only.

Note 2) Take measures to prevent condensation, freezing or solidification of impurities etc. The installation of a dryer is recommended to prevent freezing conditions (e.g. when dew point temperature is high and ambient temperature low or rate of flow is high).

Note 3) For outdoor use, be sure to implement sufficient measures to protect the operational pilot valve from rainwater. Refer to the "2-Port Solenoid Valves for Fluid Control Precautions" for protective measures.

2.2 Production batch codes

Construction	Production batch codes											
	Jan	Feb	Mar	Apr	May	Jun	Jul	Aug	Sep	Oct	Nov	Dec
2021	Zo	ZP	ZQ	ZR	ZS	ZT	ZU	ZV	ZW	ZX	Zy	ZZ
2022	Ao	AP	AQ	AR	AS	AT	AU	AV	AW	AX	Ay	AZ
...
2026	Eo	EP	EQ	ER	ES	ET	EU	EV	EW	EX	Ey	EZ

Note: The batch code is included on the product label.

2.3 JSXFA Series - Port sizes and Options

Model	Tank size	Port size			
		06	10	14	20
JSXFAE	-	•	•	•	-
JSXFAF	-	•	•	•	-
JSXFAH	4 Inch	•	-	-	-
	5 Inch	•	•	-	-
	6 Inch	-	•	•	-
	8 Inch	-	-	•	•
	10 Inch	-	-	-	•
Pilot valve orifice		•	•	-	-
Silencer		-	-	•	•

3 Installation

3.1 General

Warning

- Do not install the product unless the safety instructions have been read and understood.
- The valve is designed for pulse operation. Do not operate the valve in the open position continuously as it can cause oscillation (chattering) of the diaphragm leading to product failure due to the large amount of air consumed causing insufficient air supply on the inlet side.
- Customer to ensure that the sudden pulse of air released by the valve when operated does not generate an ignition source within the system.
- If required, an earth terminal in compliance with the applicable standard(s) may be fixed to this product using a bonnet hexagon mounting bolt. A convenient bonnet hexagon bolt can be removed, earth terminal mounted, and then replaced. See sections 6.2 and 6.3 for the disassembly and assembly procedures.

Caution

- Use steel tubing for the inlet and outlet piping.
- Use clean air filtered to 5 µm or less. Filtration to be installed upstream near to the valve.

3 Installation (continued)

- Do not rely on the valve piping ports to support the piping. Ensure that the piping is independently supported so that pulling, pressing, bending or other forces are not applied to the valve body.
- For details regarding pipe sizes, refer to the standard JSXFA Series catalogue.
- Ensure that the air supply is sufficient to meet the high flow demand of the valve when operated. If the inlet is restricted or the supply tank capacity low, then the main valve may oscillate (chatter) due to pressure drop or insufficient supply.

3.2 Environment

Warning

- Do not use in an environment where corrosive gases, chemicals, salt water or steam are present.
- Do not expose to direct sunlight. Use a suitable protective cover.
- Do not install in a location subject to vibration or impact.
- Do not mount in a location exposed to radiant heat that would result in temperatures in excess of the product's specifications.
- The valves are certified to Ex category 2GD (zones 1, 21).
- Do not mount in areas subject to electrostatic charging mechanisms.

3.3 Piping

Caution

- Before connecting piping make sure to clean up chips, cutting oil, dust etc.
- When installing piping or fittings, ensure sealant material does not enter inside the port. When using seal tape, leave 1 thread exposed on the end of the pipe/fitting.
- Tighten fittings to the specified tightening torque.

Fitting tightening torque	
Connection thread [Rc]	Tightening torque [N·m]
1/4	12 to 14
3/8	22 to 24
1/2	28 to 30
3/4	28 to 30
1	36 to 38
1 1/2	40 to 42

3.4 Valve mounting - JSXFAE and JSXFAH

3.4.1 JSXFAE

Warning

- The compression fitting is used to seal the connection between the valve and the pipework. Do not rely on the compression fitting to support the piping as it could become detached. Ensure that inlet and outlet piping is secured with separate fixings.
- Mount the valve to fixed metal piping (to ensure correct sealing of the fitting, do not expose the piping to oil or moisture).
- Insert the piping into the valve body until it stops to prevent misalignment of the piping in relation to the valve body, see fig.1.
- Tightening of the compression nuts.

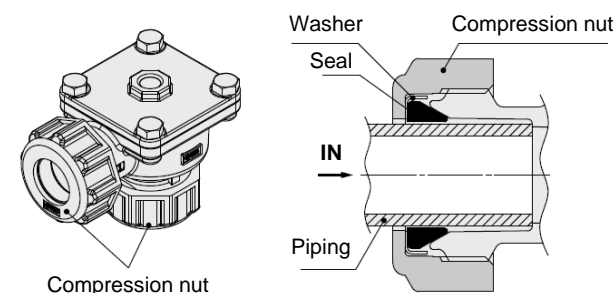

Fig.1

- Tighten the compressor nut sufficiently to prevent nut becoming loose and leakage occurring. Hand tighten, then secure with a wrench.

Tightening angle after hand-tightening	
Size	Wrench tightening angle [°]
3/4 (20A)	90 to 270
1 (25A)	135 to 315
1 1/2 (40A)	150 to 330

3 Installation (continued)

3.4.2 JSXFAH

Warning

The valve and pipe assembly are mounted to the tank, see fig.2.
Note: Tank to be provided by the customer.

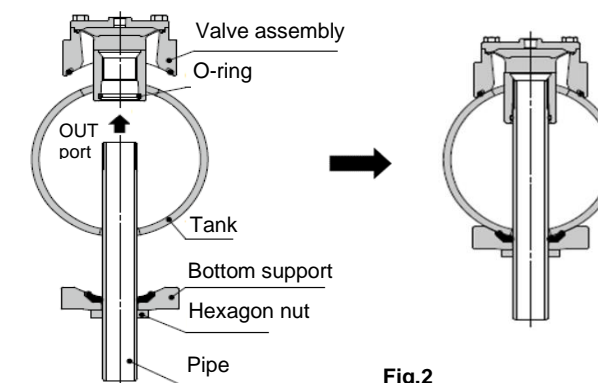

Fig.2

- Insert the pipe assembly vertically through the tank and screw it into the OUT port of the valve. Take care when engaging the pipe assembly into the valve assembly as incorrect alignment of the pipe assembly may damage the O-ring inside the valve.
- Once the pipe assembly thread is correctly engaged with the OUT port thread, continue tightening the pipe assembly until the body and the bottom support touch the tank.
- Tighten with a wrench or other tool so that the bottom support does not rotate, see fig.3.

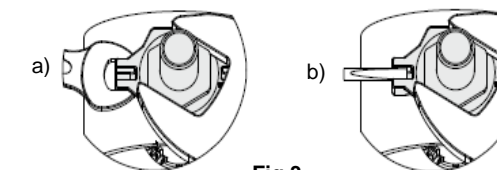

Fig.3

Note: Secure the bottom support with a wrench (method 'a' or 'b' can be used). When securing, align the tank with the curved surface of the bottom support. Tighten the pipe assembly hexagon nut with a wrench.

- Tighten the hexagon nut to the specified tightening torque.

Size	Tightening torque [N·m]
3/4 (20A)	30
1 (25A)	50
1 1/2 (40A)	50
2 (50A)	120

Caution

- Excessive tightening may damage the valve or deform or damage the tank.
- It is recommended that the tank be constructed from ANSI sch40 pipe (or pipe of equivalent strength). If a custom tank is to be fabricated suitably rated material should be used. For recommended tank hole dimensions and spacing, see Fig.4.

3 Installation (continued)

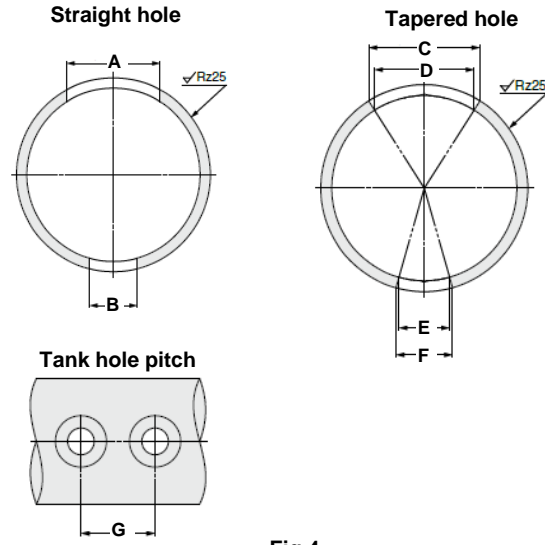

Fig.4

Port size	A	B	C	D	E	F	G (min.)
06	55	28	61.5	55	28	31.3	95
10	69	36	76	69	36	39.7	100
14	95	52	103.8	95	52	56.8	135
20	117	62	126.4	117	62	67	175

Dimensions in mm; tolerance +1, 0.

3.5 Pilot valve selection

Caution

- Valves without suffix 'A':** It is recommended to use a pilot valve with an orifice diameter of 5 mm or larger.

Correct operation of the valve is dependent on the pilot piping diameter* and length.

*The I.D. of the pilot piping must be larger than the pilot valve orifice diameter used. The max. pilot piping I.D. is 10 mm.

- Valves with suffix 'A':** These valves (available for port sizes 3/4, 1) can be operated with a pilot valve with orifice size between 3 mm and 5 mm, see Fig.5 (example showing JSXFAE-06/10).

The main valve may not operate correctly if the pilot valve orifice diameter is inadequate.

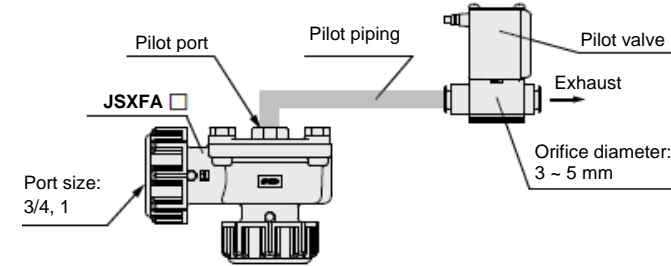

Fig.5

3.6 Lubrication

Caution

The JSXFA Series of valves do not require lubrication for correct operation and are therefore supplied un-lubricated. Lubricated air should not be supplied to these valves.

4 How to Order

Refer to JSXFA on-line catalogue for 'How to Order'.

5 Outline Dimensions

Refer to JSXFA on-line catalogue for outline dimensions.

6 Maintenance

6.1 General maintenance

Caution

- Not following proper maintenance procedures could cause the product to malfunction and lead to equipment damage.
- If handled improperly, compressed air can be dangerous.
- Maintenance of pneumatic systems should be performed only by qualified personnel.
- After performing maintenance, turn off the power supply and be sure to cut off the supply pressure. Confirm that the air is released to atmosphere.
- After installation and maintenance, apply operating pressure and power to the equipment and perform appropriate functional and leakage tests to make sure the equipment is installed correctly.
- If any electrical connections are disturbed during maintenance, ensure they are reconnected correctly and safety checks are carried out as required to ensure continued compliance with applicable national regulations.
- Do not make any modification to the product.
- Do not disassemble the product, unless required by installation or maintenance instructions.
- Refer to the Disassembly/Assembly procedures in sections 6.2 and 6.3 for the replacement of the main valve (sub-valve).
- When the valves are used for infrequent operation:
 - Switch valves at least once every 30 days to prevent malfunction.
 - To maintain the product in optimum condition, conduct a regular inspection every 6 months.
- JSXFAE type: Check the tightness of the compression nut periodically to ensure proper sealing between the valve body and the piping.

Warning

- JSXFAH type: Vibration due to the discharge of air during operation may cause loosening of the hexagon nut leading to air leakage. Check the tightness of the hexagon nut periodically to ensure the correct torque is applied.

6.2 Disassembly procedure

Caution

- Before starting the disassembly work, be sure to shut off the power supply and pressure supply, and then release the residual pressure.

- Loosen the hexagon bolts and remove the bonnet, O-ring and main valve (sub-valve). See Fig.6.

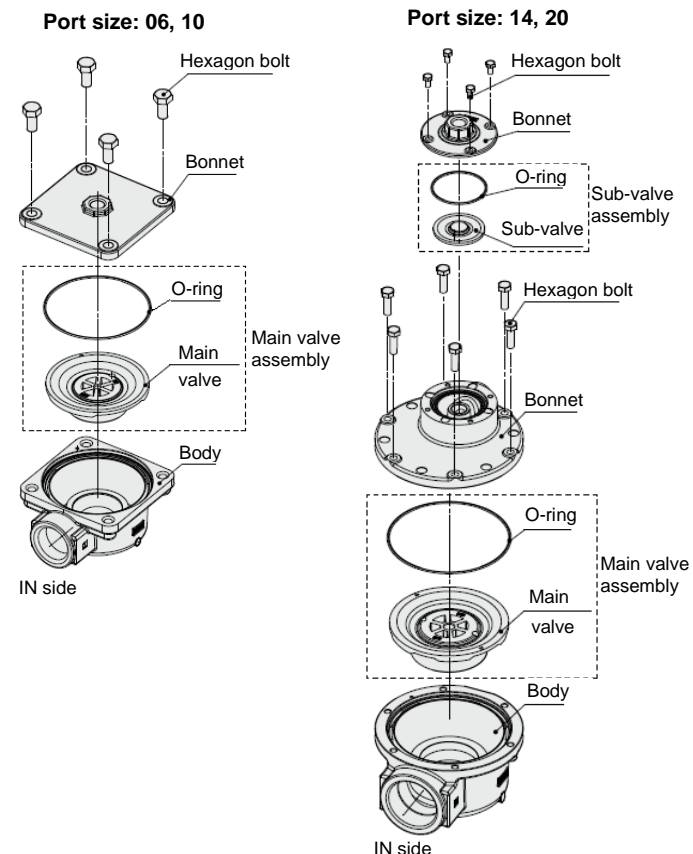

Fig.6

6 Maintenance (continued)

6.3 Assembly procedure

Caution

- Assemble the main valve (sub-valve) to the body, with reference to the mounting orientation shown in Figs.7, 8 and 9.
- Note: Incorrect assembly can lead to product malfunction.

Port size 06, 10:

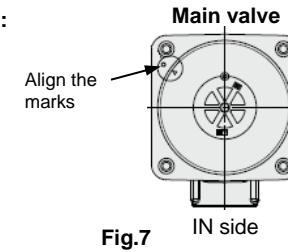

Fig.7

Port size 14 :

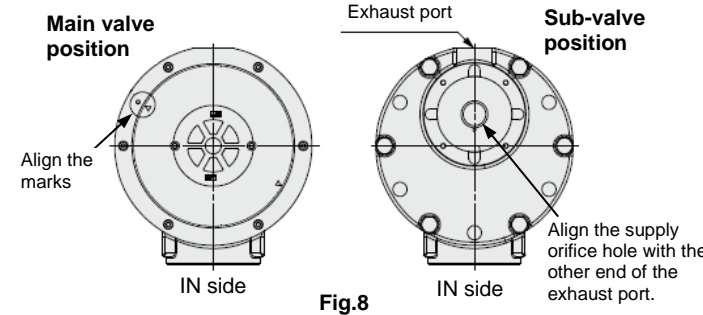

Fig.8

Port size 20:

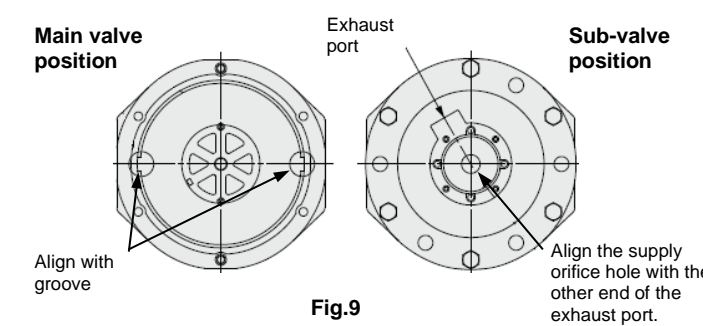

Fig.9

- Mount the O-ring into the groove in the body. Ensure that the O-ring is correctly positioned in the groove otherwise external leakage and/or operation failure may occur, see Fig.10.

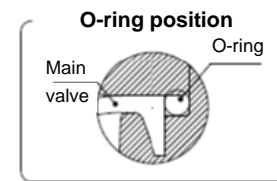

Fig.10

- Assemble the bonnet onto the body (refer to Fig.6).
- Tighten the hexagon bolts diagonally (Fig.11) using the correct tightening torque values shown in the table below.

Hexagon bolt tightening torque [N·m]			
55-JSXFA#-06#		M8	12.5 to 13.8
55-JSXFA#-10#		M8	12.5 to 13.8
55-JSXFA#-14#	Main valve	M6	5.2 to 5.7
	Sub-valve	M4	1.5 to 1.7
55-JSXFA#-20#	Main valve	M8	12.5 to 13.8
	Sub-valve	M4	1.5 to 1.7

6 Maintenance (continued)

Hexagon bolt tightening sequence:

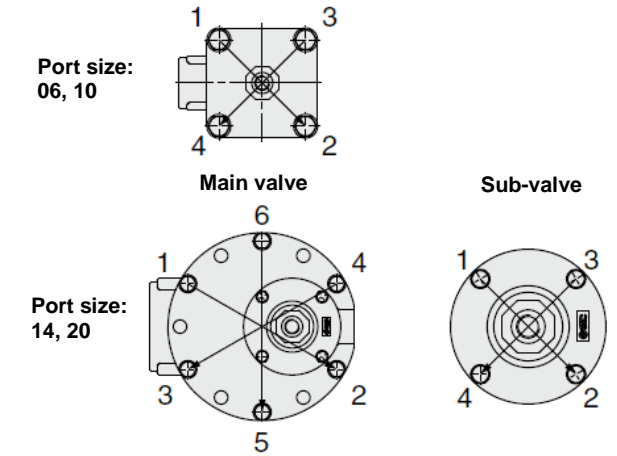

Fig.11

6.4 Replacement parts

The replacement parts available are the main valve and sub-valve elements, including O-ring, and silencer (where applicable). A list of the spare part kits is shown in the table below.

Port size	Model	Replacement part number	
		Main valve assembly (valve + O-ring)	Sub-valve assembly (valve + O-ring)
06	55-JSXFA(E/F/H)#-06#-B-#	JSXF-06B-KT	-
	55-JSXFA(E/F/H)#-06#-B-#A	JSXF-06B-A-KT	-
10	55-JSXFA(E/F/H)#-10#-B-#	JSXF-10B-KT	-
	55-JSXFA(E/F/H)#-10#-B-#A	JSXF-10B-A-KT	-
14	55-JSXFA(E/F)#-14#-B-(S)#	JSXF-14B-KT	JSXF-14B-KT2
	55-JSXFAH#-14#-B-(S)#	JSXF-14B-1-KT	
20	55-JSXFAH#-20#-B-(S)#	JSXF-20B-KT	

Silencer spare part number: AN30-03 (Rc, G thread)
AN30-N03 (NPT thread)

7 Limitations of Use

7.1 Limited warranty and disclaimer/compliance requirements

Refer to Handling Precautions for SMC Products.

Warning

- Refer to Ex classification for the product.
- Refer to the 'Special conditions of use', section 1.2.
- Use of the JSXFAH immersion type valve requires mounting into a suitable tank supplied by the customer. It is the customer's responsibility to ensure compliance with the applicable explosive atmosphere standards of the final valve/tank assembly.

7.2 Low temperature operation

Warning

A high dew point in low ambient temperature or a high flow rate may cause freezing. In such cases, take measures to prevent freezing by, for example, installing an air dryer or keeping the valve body warm.

8 Product Disposal

This product shall not be disposed of as municipal waste. Check your local regulations and guidelines to dispose this product correctly, in order to reduce the impact on human health and the environment.

9 Contacts

Refer to www.smcworld.com or www.smc.eu for your local distributor/importer.

SMC Corporation

URL : <https://www.smcworld.com> (Global) <https://www.smc.eu> (Europe)
SMC Corporation, 4-14-1, Sotokanda, Chiyoda-ku, Tokyo 101-0021, Japan
Specifications are subject to change without prior notice from the manufacturer.
© 2023 SMC Corporation All Rights Reserved.
Template DKP50047-F-085M