

Suction Cup/With Non-slip Feature

Bowl Shape	ø32, ø40, ø50, ø63, ø80, ø100
Bowl Bellows Shape	ø32, ø40, ø50, ø63, ø80, ø100
Oval Flat Shape	16 x 50, 30 x 90, 40 x 80, 50 x 100



Longer life (More than twice that of urethane cups)

Cup material: **FS61** (Fluoro-based rubber) with excellent abrasion resistance
 Reduced number of cup replacements

Non-slip special ribs

Diagonal ribs are radially arranged to secure the gripping force in all directions.

- Prevents workpiece slippage
- Secure adsorbing and transferring are possible.

Bowl shape with excellent flexibility

Curved workpieces can also be adsorbed.

Horizontal holding force: 387 N (Cup diameter ø100)*1
 Suitable for high-temperature workpieces (200°C)*1

*1 For details, refer to the specifications on pages 5, 12, and 20.

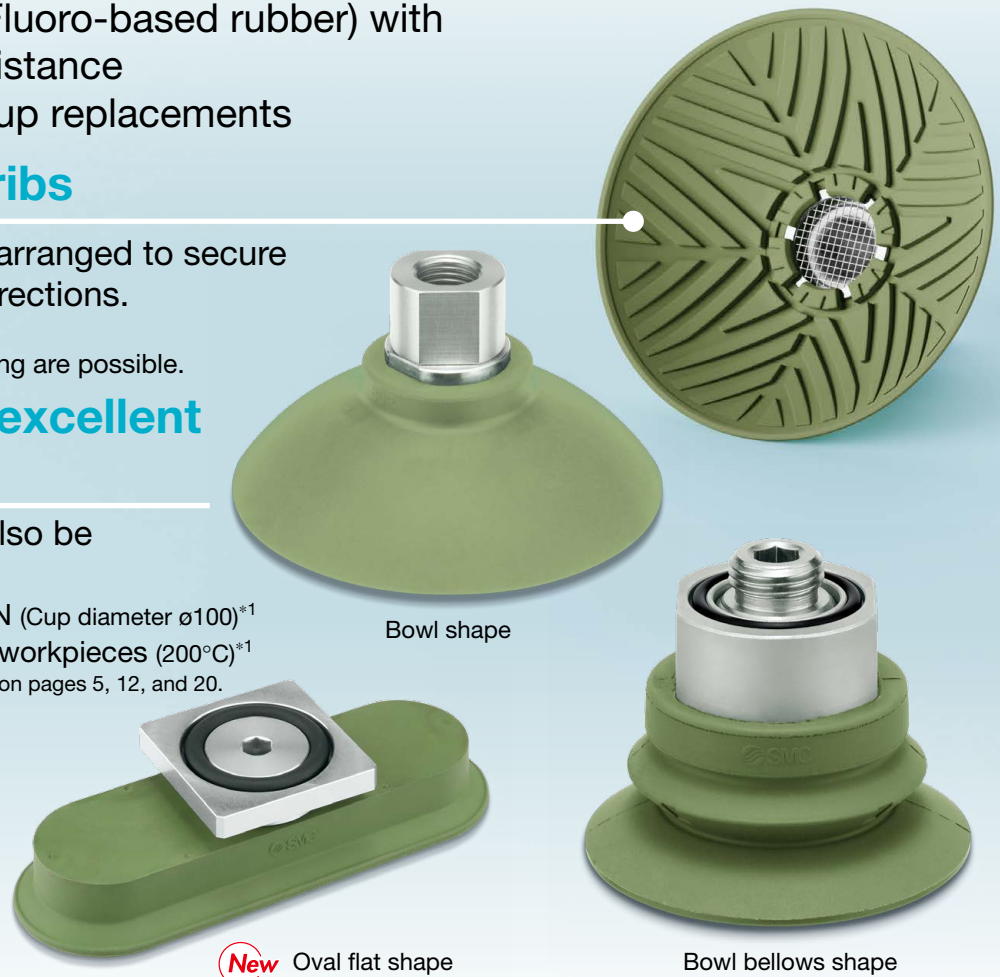

Suitable for workpieces with oil film

As oil is ejected to the grooves between special ribs, the lateral slipping of workpiece can be suppressed even on a steel plate with oil film.

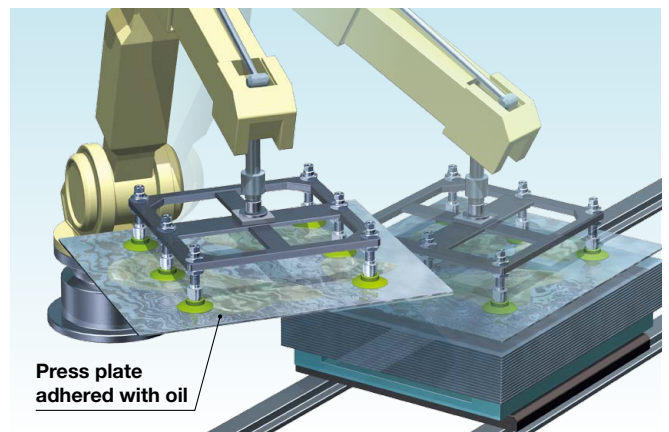
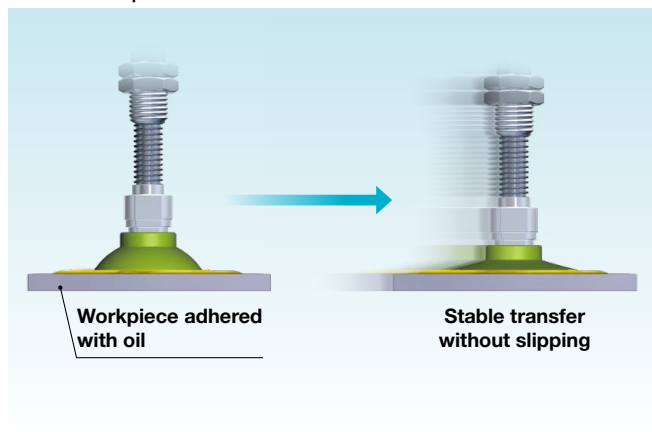

ZP3M Series



CAT.ES100-147C

Suction Cup/With Non-slip Feature **ZP3M Series**

Mesh filter (Option)

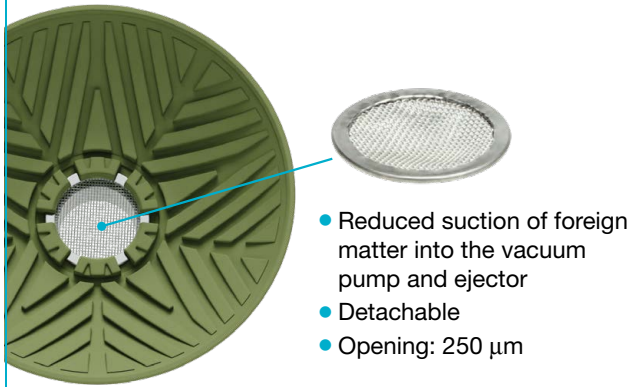

Insert-molded cup

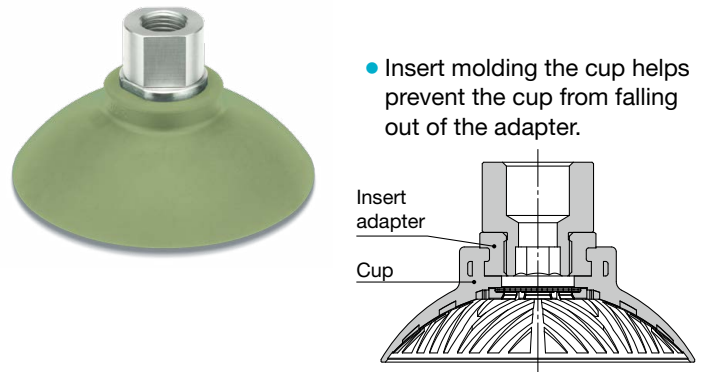

Mounting

① Mounting with a hexagon wrench
(Adapter (Male thread/Female thread))

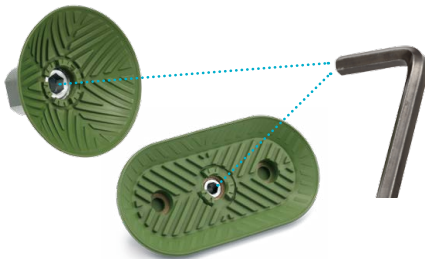

② Mounting with a standard wrench
(Adapter (Male thread/Female thread))



③ Square adapter mounting

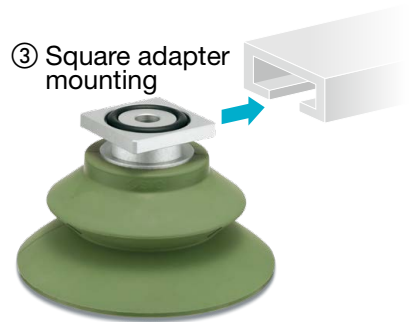

Bowl bellows shape

Discharge time reduced by max. **40%**
(horizontal transfer during adsorption)

Transfer conditions

Cup diameter: ø50, Workpiece mass: 1.3 kg,
Supply pressure: -85 kPa, Acceleration/Deceleration: 5 [G]

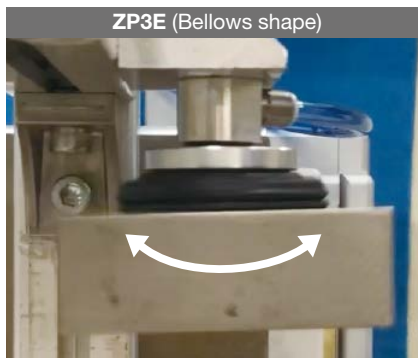
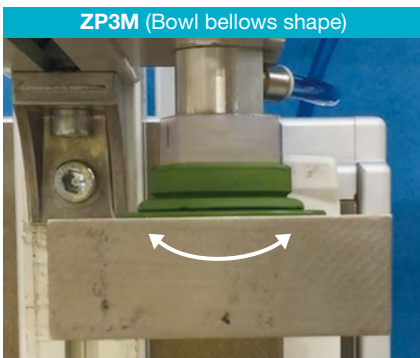

Relationship between the amplitude and time

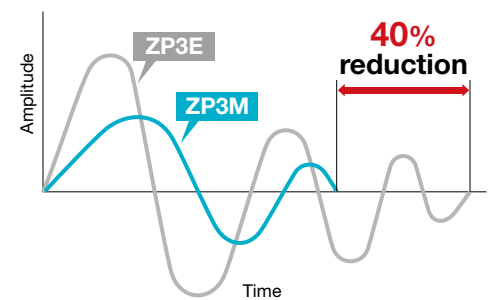

Deflection Small Discharge time **0.18 s** **Deflection Large** Discharge time **0.30 s**

Anti-stick grooves

Anti-stick grooves/Improved durability

The anti-stick grooves on the circumference prevent the bellows from sticking during suction. This reduces returning failure after the workpiece is released.

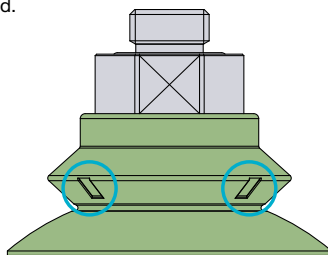

The bowl shape can handle curved workpieces.

The cup follows the workpiece shape, making stable adsorption possible.

Bowl-shape skirt with flexibility

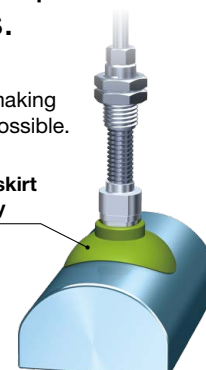

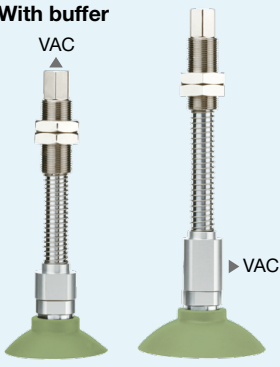

Bowl Shape Variations

Type	Mounting	Buffer specifications	Vacuum inlet direction	Connection		Vacuum inlet		Page	
				Type	Size		Size		
					Cup diameter: $\phi 32$ to $\phi 50$	Cup diameter: $\phi 63$ to $\phi 100$	Cup diameter: $\phi 32$ to $\phi 50$		Cup diameter: $\phi 63$ to $\phi 100$
	Direct mounting	—	Vertical	Male thread	M10 x 1.0	M16 x 1.5	Use the connection thread.		
				Female thread	G1/4				
					M14 x 1.0				
Square adapter	□31.8								
	Plate mounting	JB	Vertical	Male thread	M18 x 1.5	M22 x 1.5	Rc1/8		
			Lateral				M5 x 0.8	Rc1/8	
			KB	Vertical	Male thread	M22 x 1.5	M26 x 1.5	Rc1/8	
				Lateral				M5 x 0.8	Rc1/8

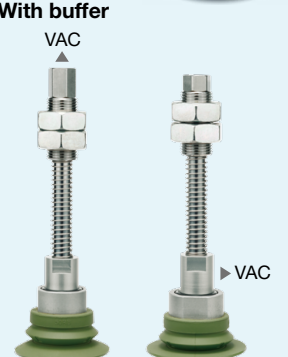
Bowl Bellows Shape Variations

Type	Mounting	Buffer specifications	Vacuum inlet direction	Connection		Vacuum inlet		Page	
				Type	Size		Size		
					Cup diameter: $\phi 32$ to $\phi 50$	Cup diameter: $\phi 63$ to $\phi 100$	Cup diameter: $\phi 32$ to $\phi 50$		Cup diameter: $\phi 63$ to $\phi 100$
	Direct mounting	—	Vertical	Male thread	M10 x 1.0	M16 x 1.5	Use the connection thread.		
				Female thread	G1/4				
					M14 x 1.0				
Square adapter	□31.8								
	Plate mounting	JB	Vertical	Male thread	M18 x 1.5	M22 x 1.5	Rc1/8		
			Lateral				M5 x 0.8	Rc1/8	
			KB	Vertical	Male thread	M22 x 1.5	M26 x 1.5	Rc1/8	
				Lateral				M5 x 0.8	Rc1/8

Oval Flat Shape Variations

Type	Mounting	Vacuum inlet direction	Connection			Vacuum inlet			Page
			Type	Size		Type	Size		
				Cup size: 16 x 50, 30 x 90	Cup size: 40 x 80, 50 x 100		Cup size: 16 x 50, 30 x 90	Cup size: 40 x 80, 50 x 100	
With adapter 	Direct mounting	Vertical	Male thread	M10 x 1.0	M16 x 1.5	—	Use the connection thread.		
			Female thread	G1/4					
				G3/8					
	Square adapter	□31.8							
	Plate mounting	Vertical	Male thread	M10 x 1.5	M22 x 1.5	M26 x 1.5	Female thread	M5 x 0.8	
				M14 x 1.5				Rc1/8	
G1/4									
With buffer 	Plate mounting	Vertical	Male thread	M22 x 1.5	M26 x 1.5	Female thread	Rc1/8		

Compatible with workpieces with an elongated adsorption surface

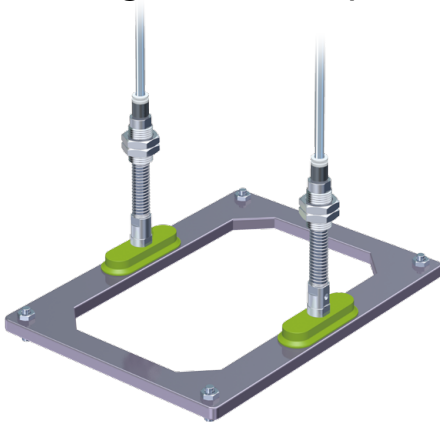

CONTENTS

Suction Cup/With Non-slip Feature *ZP3M Series*

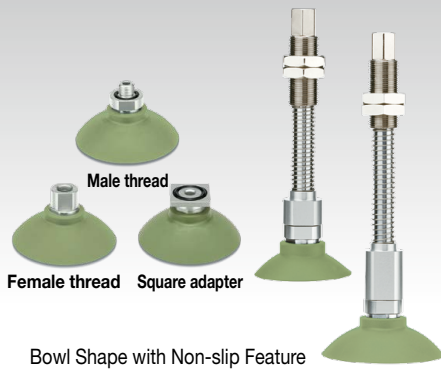

- **Bowl Shape with Non-slip Feature**

How to Order	p. 5
Specifications	p. 5
Dimensions/Models	p. 6
Construction	p. 10
Mounting Bracket Assembly	p. 11

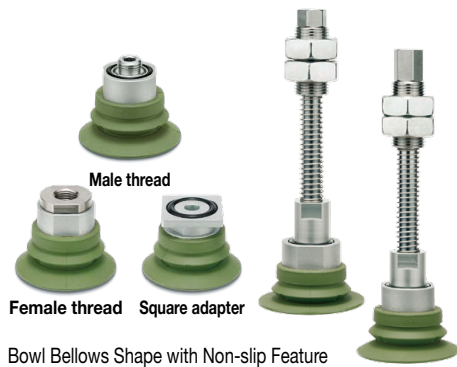

- **Bowl Bellows Shape with Non-slip Feature**

How to Order	p. 12
Specifications	p. 12
Dimensions/Models	p. 13
Construction	p. 18
Mounting Bracket Assembly	p. 19

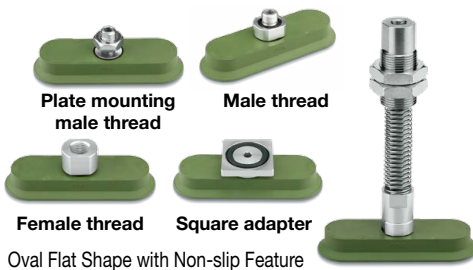

- **Oval Flat Shape with Non-slip Feature**

How to Order	p. 20
Specifications	p. 20
Dimensions/Models	p. 21
Construction	p. 24
Mounting Bracket Assembly	p. 25

Specific Product Precautions	p. 26
------------------------------------	-------

Suction Cup/ Bowl Shape with Non-slip Feature ZP3M Series

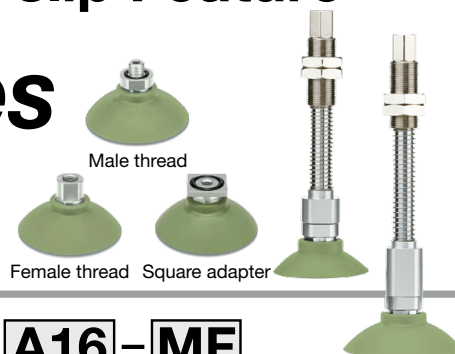

How to Order

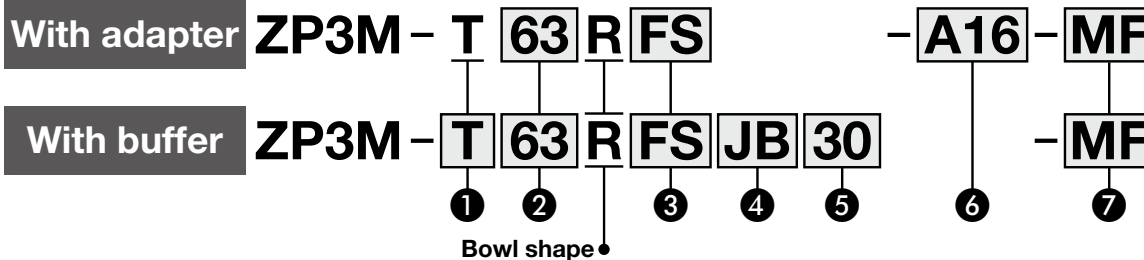

① Vacuum inlet direction

T	Vertical
Y	Lateral

⑤ Buffer stroke

Stroke [mm]	Cup size	
	All sizes	
10	●	●
30	●	●
50	●	●

⑦ Mesh filter

Nil	None
MF	With mesh filter

Mesh filter unit

Part no.	Cup diameter	
	ø32 to ø50	ø63 to ø100
ZPMF-60-D13	●	—
ZPMF-60-D18	—	●

② Cup diameter

32	ø32
40	ø40
50	ø50
63	ø63
80	ø80
100	ø100

③ Material

Symbol	Material	Color
FS	FS61 (Fluoro-based rubber)	Green

④ Buffer specifications

JB	Rotating, With bushing
KB	Non-rotating, With bushing

⑥ Connection thread and type

Mounting	Type	Symbol	Size	Cup diameter	
				ø32 to ø50	ø63 to ø100
Direct mounting	Male thread	A10	M10 x 1.0	●	—
		A16	M16 x 1.5	—	●
		AG02	G1/4	●	●
	Female thread	B14	M14 x 1.0	●	●
		BG02	G1/4	●	●
		BG03	G3/8	●	●
	Square adapter	S32	□31.8	●	●

* The adapter and cup are adhered to each other and cannot be disassembled.

Specifications

Cup Material

Material	FS61 (Fluoro-based rubber)
Color of rubber	Green
Rubber hardness (Shore A: ±5°)	65
Operating temperature range*1	0°C to 200°C
Ambient temperature	0°C to 150°C

*1 Surface temperature of the workpiece to be adsorbed

Adapter Specifications

Connection Cup diameter	Male thread		Female thread	Square adapter
	ø32 to ø50	ø63 to ø100	ø32 to ø100	ø32 to ø100
Size	M10 x 1.0 G1/4	M16 x 1.5 G1/4	M14 x 1.0 G1/4 G3/8	□31.8
Vacuum inlet	Use the connection thread and type.			

Buffer Specifications

Non-rotating specification	Cup diameter		ø32 to ø50			ø63 to ø100		
	Stroke [mm]		10	30	50	10	30	50
JB Rotating, With bushing	Connection thread		M18 x 1.5			M22 x 1.5		
	Spring reactive force [N]	At 0 stroke	5.0			10.0		
		At full stroke	6.5	8.5	10.5	11.5	13.5	15.5
KB Non-rotating, With bushing	Connection thread		M22 x 1.5			M26 x 1.5		
	Spring reactive force [N]	At 0 stroke	5.0			10.0		
		At full stroke	7.0	9.0	11.0	13.5	15.5	17.5

Cup Specifications

Part no.	Horizontal holding force [N]*1		Minimum curvature radius for adsorption [mm]*2
	Without oil	With oil	
ZP3M-T32RFS	47	21	14
ZP3M-T40RFS	81	53	15
ZP3M-T50RFS	111	74	20
ZP3M-T63RFS	170	108	27.5
ZP3M-T80RFS	231	178	36
ZP3M-T100RFS	387	224	46

*1 These are actual measurement values when flat workpieces were adsorbed at a setting vacuum pressure of -60 kPa; however, they are not guaranteed values. (According to SMC's tests)
The values vary depending on the conditions (shape, surface roughness, oil type, oil amount, and other conditions) of the workpiece.

*2 These are actual measurement values when cylindrical workpieces were adsorbed at a setting vacuum pressure of -85 kPa; however, they are not guaranteed values. (According to SMC's tests)

Mesh Filter Specifications

Mesh filter	60
Opening	250 μm

Buffer assembly part no. p. 11

* The mounting nut is shipped together with the product (unassembled).

Dimensions/Models

With adapter Direct mounting type (Male thread)

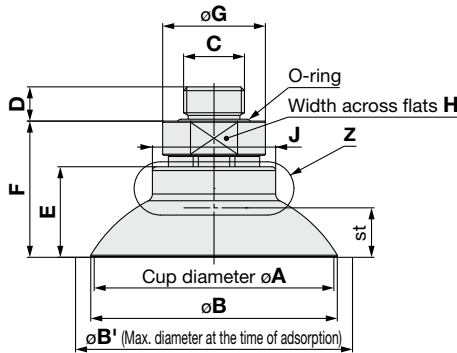

ZP3M - T 63 **R** FS - A16 - MF



		Cup diameter [mm]	
		$\phi 32$ to $\phi 50$	$\phi 63$ to $\phi 100$
A10	M10 x 1.0	○	—
A16	M16 x 1.5	—	○
AG02	G1/4	○	○

Model						A	B	B ¹ *2	C	D	E	F	G	H	J	K	st*2	Min. opening hole size of the adapter	Weight [g]
Vacuum inlet direction	1 Cup diameter	Form	2 Material *1	3 Connection thread	4 Mesh filter														
ZP3M	T	R	FS	Nil	MF	32	33.2	38.3	M10 x 1.0	7	14.3	23.8	20	17	20.4	5	6	$\phi 5$	16.1
									G1/4	6.5		24.1	25	22					24.5
						40	41.3	47.8	M10 x 1.0	7	17.8	27.3	20	17	21	5	8.4	$\phi 5$	17.3
									G1/4	6.5		27.6	25	22					25.7
						50	51.6	58.6	M10 x 1.0	7	19.4	28.9	20	17	21.4	5	10.4	$\phi 5$	21.1
									G1/4	6.5		29.2	25	22					29.5
	63	64.8	73.3	M16 x 1.5	9	24.1	36.1	27	24	32.4	8	12	$\phi 8$	47.1					
				G1/4	6.5		35.6									46.7			
	80	80.6	81.8	M16 x 1.5	9	27.1	39.1	27	24	33	8	14.4	$\phi 8$	61.3					
				G1/4	6.5		38.6									60.9			
	100	102.2	113.4	M16 x 1.5	9	33.9	45.9	27	24	34.4	8	20.1	$\phi 8$	96.7					
				G1/4	6.5		45.4									100.4			

*1 FS: FS61 (Fluoro-based rubber)

*2 B': Maximum cup diameter at the time of adsorption, st: The stroke is a guide value at the setting vacuum pressure of -90 kPa.

With adapter Direct mounting type (Female thread)

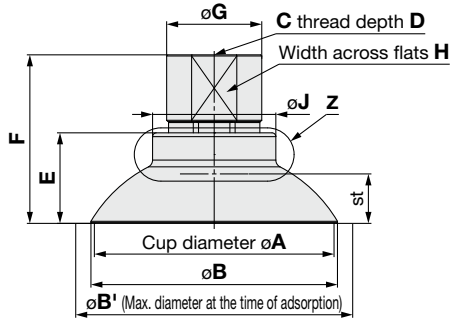

ZP3M - T 63 **R** FS - B14 - MF



		Cup diameter [mm]	
		$\phi 32$ to $\phi 100$	
B14	M14 x 1.0	○	
BG02	G1/4	○	
BG03	G3/8	○	

Model						A	B	B ¹ *2	C	D	E	F	G	H	J	K	st*2	Min. opening hole size of the adapter	Weight [g]
Vacuum inlet direction	1 Cup diameter	Form	2 Material *1	3 Connection thread	4 Mesh filter														
ZP3M	T	R	FS	Nil	MF	32	33.2	38.3	M14 x 1.0	8	14.3	31.6	23	19	20.4	5	6	$\phi 5$	20.9
									G1/4	11		33.6	20	17					19.1
						40	41.3	47.8	M14 x 1.0	8	17.8	35.1	23	19	21	5	8.4	$\phi 5$	22.1
									G1/4	11		37.1	20	17					20.3
						50	51.6	58.6	M14 x 1.0	8	19.4	36.7	23	19	21.4	5	10.4	$\phi 5$	25.9
									G1/4	11		38.7	20	17					24.1
						63	63.5	64.8	M14 x 1.0	8	24.1	41.6	23	19	32.4	8	12	$\phi 8$	42.2
									G1/4	11		42.6	22	19					42.5
						80	80.6	81.8	M14 x 1.0	8	27.1	44.6	23	19	33	8	14.4	$\phi 8$	56.4
									G1/4	11		45.6	22	19					56.7
						100	102.2	113.4	M14 x 1.0	8	33.9	51.4	23	19	34.4	8	20.1	$\phi 8$	92.3
									G1/4	11		52.4	22	19					92.6
	32	33.2	38.3	M14 x 1.0	8	14.3	31.6	23	19	20.4	5	6	$\phi 5$	20.9					
				G3/8	11.4		34.1	26	22					26.3					
	40	41.3	47.8	M14 x 1.0	8	17.8	35.1	23	19	21	5	8.4	$\phi 5$	22.1					
				G3/8	11.4		37.6	26	22					27.5					
	50	51.6	58.6	M14 x 1.0	8	19.4	36.7	23	19	21.4	5	10.4	$\phi 5$	25.9					
				G3/8	11.4		39.2	26	22					31.3					
	63	63.5	64.8	M14 x 1.0	8	24.1	41.6	23	19	32.4	8	12	$\phi 8$	42.2					
				G3/8	11.4		44.6	25	22					46.4					
	80	80.6	81.8	M14 x 1.0	8	27.1	44.6	23	19	33	8	14.4	$\phi 8$	56.4					
				G3/8	11.4		47.6	25	22					60.5					
	100	102.2	113.4	M14 x 1.0	8	33.9	51.4	23	19	34.4	8	20.1	$\phi 8$	92.3					
				G3/8	11.4		54.4	25	22					96.5					

*1 FS: FS61 (Fluoro-based rubber)

*2 B': Maximum cup diameter at the time of adsorption, st: The stroke is a guide value at the setting vacuum pressure of -90 kPa.

ZP3M Series

Dimensions/Models

With adapter Direct mounting type (Square adapter)

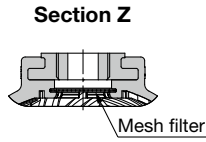
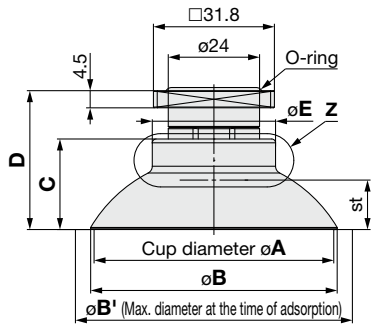

ZP3M - T **①** **②** **③** R FS - S32 - MF



		Model					A	B	B ^{*2}	C	D	E	st ^{*2}	Min. opening hole size of the adapter	Weight [g]
Vacuum inlet direction	① Cup diameter	Form	② Material *1	Connection thread	③ Mesh filter										
ZP3M	T	R	FS	S32	Nil MF	32	33.2	38.3	14.3	26.3	20.4	6	ø5	26.1	
						40	41.3	47.8	17.8	29.8	21	8.4	ø5	27.3	
						50	51.6	58.6	19.4	31.4	21.4	10.4	ø5	31.1	
						63	64.8	73.3	24.1	36.8	32.4	12	ø8	48.7	
						80	81.8	92.2	27.1	39.8	33	14.4	ø8	62.8	
						100	102.2	113.4	33.9	46.6	34.4	20.1	ø8	97.4	

*1 FS: FS61 (Fluoro-based rubber)

*2 B': Maximum cup diameter at the time of adsorption, st: The stroke is a guide value at the setting vacuum pressure of -90 kPa.

Square adapter mounting groove dimensions (Recommended)

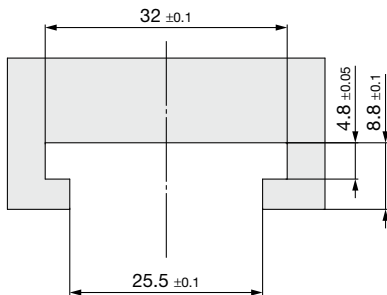

* For details on how to use the square adapter, refer to "Mounting" on page 26.

Dimensions/Models

With buffer Plate mounting type (Vacuum inlet direction: Vertical)

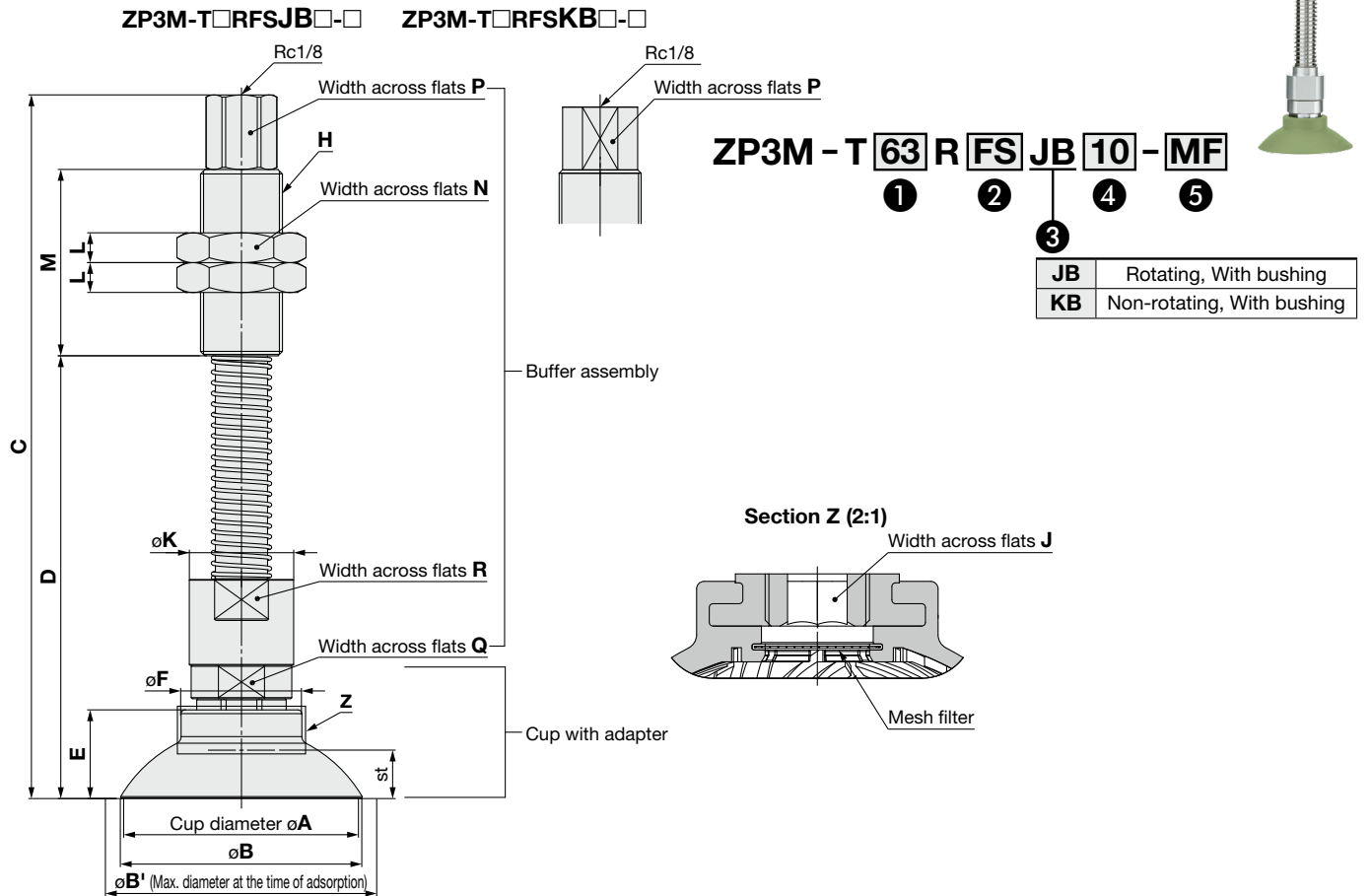

Model		Vacuum inlet direction					A	B	B ^{*2}	C	D	E	F	H		J	K	L		M	N			P	Q	R	st ^{*2}	Min. opening hole size of the adapter	Weight [g]	
		① Cup diameter	② Form	③ Material ^{*1}	④ Buffer spec.	⑤ Buffer stroke								⑥ Mesh filter	JB			KB	JB		KB	JB	KB						JB	KB
ZP3M	T	R	FS	JB	KB	Nil	MF	32	33.2	38.3	123.3	71.3	14.3	20.4	M18 x 1.5	M22 x 1.5	5	19	11	35	27	30	14	18	17	16	8.4	ø3	205	245.2
											148.3	96.3																	219.5	271.2
											168.3	116.3																	231	291.1
											126.8	74.8																	206.2	246.9
											171.8	119.8																	232.2	292.8
											128.4	76.4																	210	250.0
		50	51.6	58.6	153.4	101.4	19.4	21.4	M22 x 1.5	M26 x 1.5	8	28	8	50	30	32	17	21	24	24	20.1	14.4	ø4	224.5	276.0					
					173.4	121.4																		236	295.9					
					164.1	94.1																		355	389.3					
					189.1	119.1																		383.8	425.4					
					209.1	139.1																		406.7	453.1					
					167.1	97.1																		369.2	416.4					
	63	64.8	73.3	192.1	122.1	27.1	33	M22 x 1.5	M26 x 1.5	8	28	8	50	30	32	17	21	24	24	20.1	14.4	ø4	397.9	452.5						
				212.1	142.1																		420.9	480.2						
				173.9	103.9																		404.6	418.7						
				198.9	128.9																		433.4	454.8						
				218.9	148.9																		456.3	482.4						
				198.9	128.9																		433.4	454.8						
	218.9	148.9	456.3	482.4																										

*1 FS: FS61 (Fluoro-based rubber)

*2 B': Maximum cup diameter at the time of adsorption, st: The stroke is a guide value at the setting vacuum pressure of -90 kPa.

ZP3M Series

Dimensions/Models

With buffer Plate mounting type (Vacuum inlet direction: Lateral)

ZP3M-Y□RFSJB□-□ ZP3M-Y□RFSKB□-□

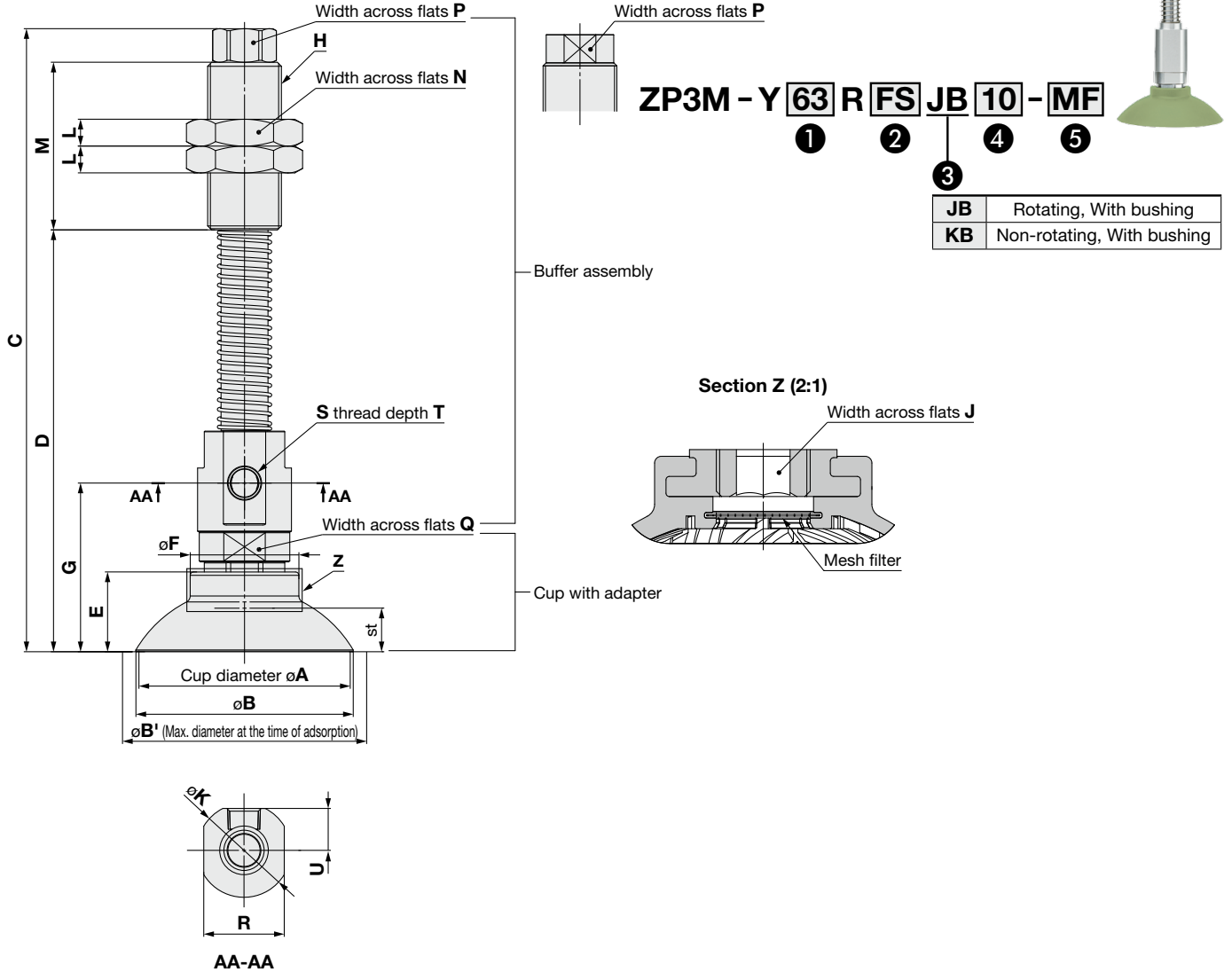

Vacuum inlet direction	Model					A	B	B ^{*2}	C	D	E	F	G	H		J	K	L	M	N		P		Q	R	S	T	U	st ^{*2}	Min. opening hole size of the adapter	Weight [g]					
	① Cup diameter	② Form	③ Material ^{*1}	④ Buffer spec.	⑤ Buffer stroke									JB	KB					JB	KB	JB	KB													
																															JB	KB	JB	KB	JB	KB
ZP3M	Y	R	FS	JB	KB	Nil	MF	10	30	50	118.3	74.3	143.3	99.3	14.3	20.4	33.7	M18 x 1.5	M22 x 1.5	5	19	11	35	27	30	14	18	17	16	M5 x 0.8	5	8.5	8.4	ø5	203.2	234.9
																																			219.1	262.3
																																			231.6	283.3
																																			204.4	236.6
																																			220.3	264.0
																																			232.8	285.0
	Y	R	FS	JB	KB	Nil	MF	10	30	50	121.8	77.8	146.8	102.8	17.8	21	37.2	M18 x 1.5	M22 x 1.5	5	19	11	35	27	30	14	18	17	16	M5 x 0.8	5	8.5	8.4	ø5	204.4	236.6
																																			220.3	264.0
																																			232.8	285.0
																																			208.2	239.7
																																			224.1	267.1
																																			236.6	288.0
Y	R	FS	JB	KB	Nil	MF	10	30	50	161.1	101.1	186.1	126.1	24.1	32.4	50.6	M18 x 1.5	M22 x 1.5	5	19	11	35	27	30	14	18	17	16	M5 x 0.8	5	8.5	8.4	ø5	355.6	376.3	
																																		386.8	414.9	
																																		411.7	444.5	
																																		369.7	403.4	
																																		400.9	442.0	
																																		425.9	471.6	
Y	R	FS	JB	KB	Nil	MF	10	30	50	164.1	104.1	189.1	129.1	27.1	33	53.6	M22 x 1.5	M26 x 1.5	8	28	8	50	30	32	17	21	24	24	Rc1/8	-	12.5	14.4	ø8	369.7	403.4	
																																		400.9	442.0	
																																		425.9	471.6	
																																		405.2	405.7	
																																		436.4	444.2	
																																		461.3	473.9	

*1 FS: FS61 (Fluoro-based rubber)

*2 B²: Maximum cup diameter at the time of adsorption, st: The stroke is a guide value at the setting vacuum pressure of -90 kPa.

Construction

With adapter

ZP3M-T□RFS-A□ ZP3M-T□RFS-B□ ZP3M-T□RFS-S32

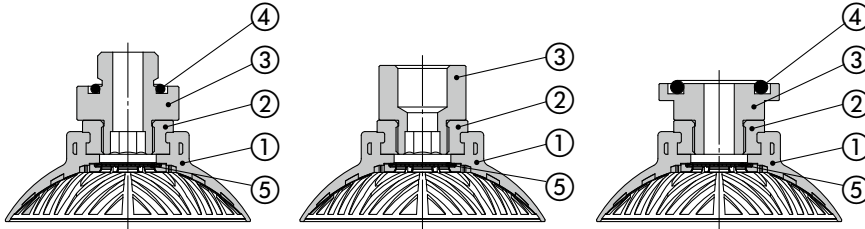

Component Parts

No.	Description	Material
1	Cup	FS61 (Fluoro-based rubber)
2	Insert adapter	Aluminum alloy
3	Adapter	Aluminum alloy (Anodized)
4	O-ring	FKM
5	Mesh filter	Stainless steel

* The parts 1, 2, and 3 are adhered to each other and cannot be disassembled.

With buffer

ZP3M-T□RFS□(JB/KB)□-□ ZP3M-Y□RFS□(JB/KB)□-□

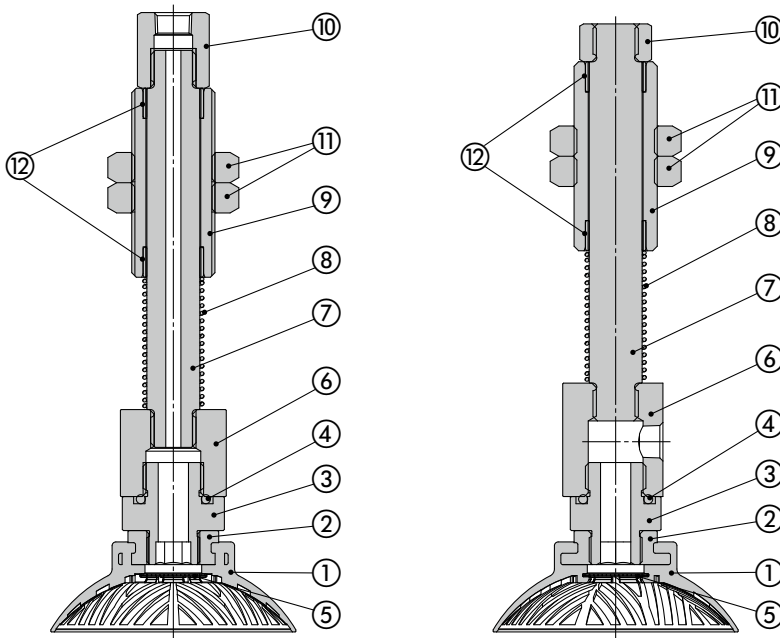

Component Parts

No.	Description	Material	Note
1	Cup	FS61 (Fluoro-based rubber)	—
2	Insert adapter	Aluminum alloy	—
3	Adapter	Aluminum alloy (Anodized)	—
4	O-ring	FKM	—
5	Mesh filter	Stainless steel	—
6	Adapter	Aluminum alloy (Anodized)	—
7	Piston rod	Structural steel (Hard chrome plating)	ZP3M-(T,Y)□RFSJB□-□
		Stainless steel	ZP3M-(T,Y)□RFSKB□-□
8	Return spring	Stainless steel	—
9	Buffer body	Brass (Electroless nickel plating)	—
10	Buffer adapter	Brass (Electroless nickel plating)	—
11	Nut	Steel (Zinc chromated)	M18 x 1.5
		Structural steel (Nickel plating)	M22 x 1.5
		Structural carbon steel (Nickel plating)	M26 x 1.5
12	Bushing	—	—

* The parts 1, 2, and 3 are adhered to each other and cannot be disassembled.

Replacement Parts: Mesh Filter Unit

Part no.	Cup diameter	
	ø32 to ø50	ø63 to ø100
ZPMF-60-D13	●	—
ZPMF-60-D18	—	●



ZP3M Series

Mounting Bracket Assembly

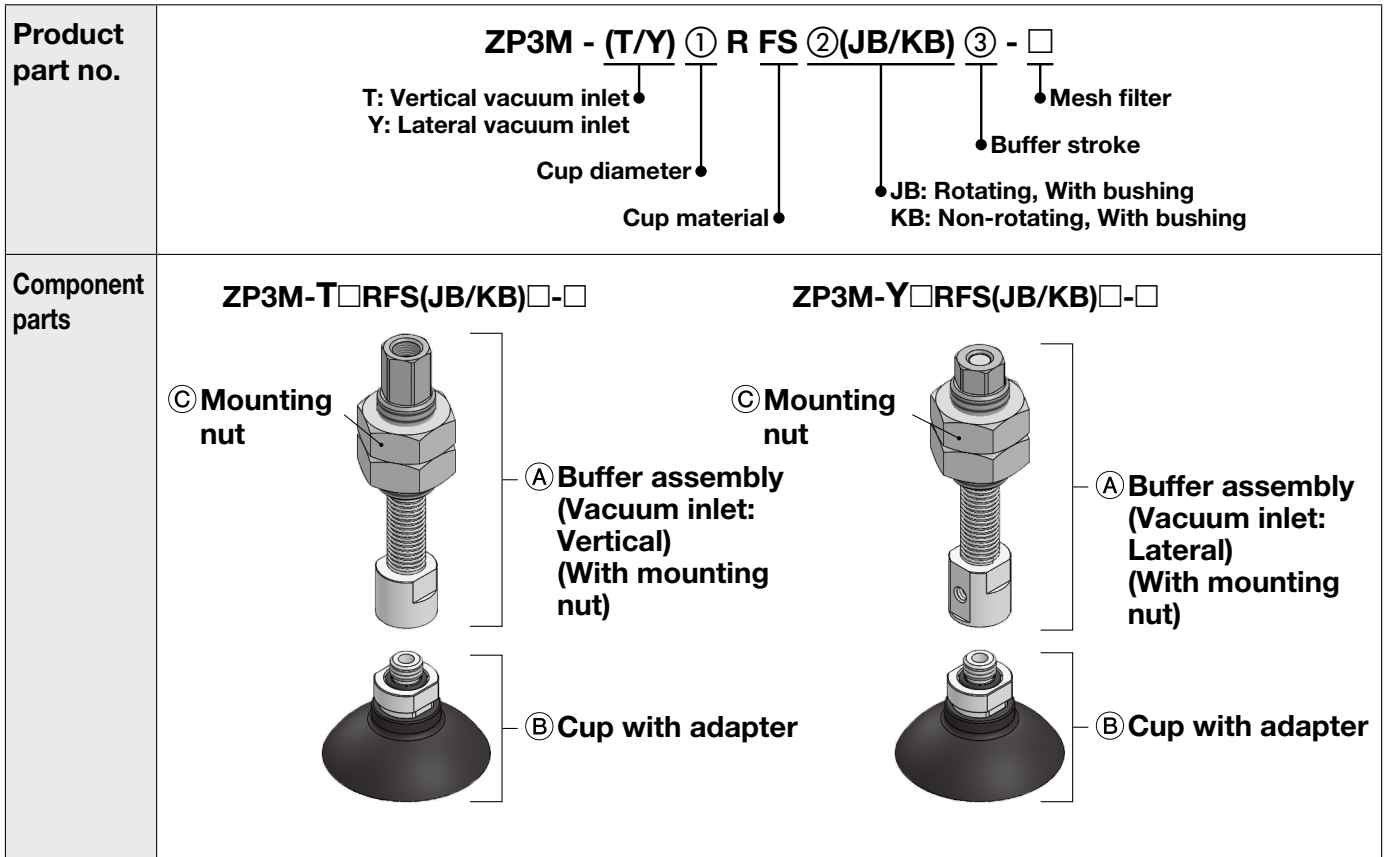

		Symbol	① Cup diameter						
			32	40	50	63	80	100	
Ⓐ Buffer assembly (With mounting nut)	③ Buffer stroke	10	ZP3EB-(T/Y)1(JB/KB)10			ZP3EB-(T/Y)2(JB/KB)10			
		30	ZP3EB-(T/Y)1(JB/KB)30			ZP3EB-(T/Y)2(JB/KB)30			
		50	ZP3EB-(T/Y)1(JB/KB)50			ZP3EB-(T/Y)2(JB/KB)50			
Ⓑ Cup with adapter		M10 x 1.0	ZP3M-T(32/40/50)RFS-A10-□			-			
		M16 x 1.5	-			ZP3M-T(63/80/100)RFS-A16-□			
Ⓒ Mounting nut (Single unit)	② Buffer specifications	JB	M18 x 1.5	ZPNA-M18			-		
			M22 x 1.5	-			ZPNA-M22		
		KB	M22 x 1.5	ZPNA-M22			-		
			M26 x 1.5	-			ZPNA-M26		

[Buffer assembly part number example]

Product part no. **ZP3M - T63RFS JB 10**

Buffer assembly **ZP3EB - T2 JB 10**

② Buffer stroke

Suction Cup/ Bowl Bellows Shape with Non-slip Feature ZP3M Series

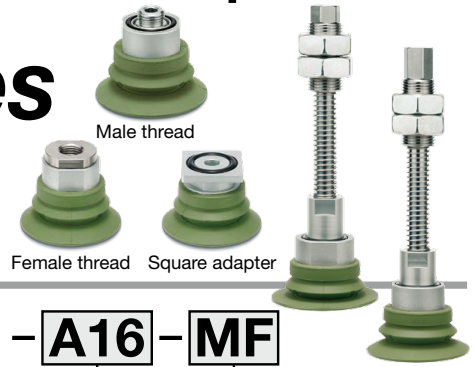

How to Order

With adapter **ZP3M - T 63 RB FS - A16 - MF**

With buffer **ZP3M - T 63 RB FS JB 30 - MF**

① Vacuum inlet direction ② Cup diameter ③ Material

④ Buffer specifications ⑤ Buffer stroke ⑥ Connection thread and type ⑦ Mesh filter

Bowl bellows shape ●

① Vacuum inlet direction

T	Vertical
Y	Lateral

⑤ Buffer stroke

Stroke [mm]	Cup size	
	All sizes	
10	●	●
30	●	●
50	●	●

⑦ Mesh filter

Nil	None
MF	With mesh filter

Mesh filter unit

Part no.	Cup diameter	
	ø32 to ø50	ø63 to ø100
ZPMF-60-D13	●	—
ZPMF-60-D18	—	●

② Cup diameter

32	ø32
40	ø40
50	ø50
63	ø63
80	ø80
100	ø100

③ Material

Symbol	Material	Color
FS	FS61 (Fluoro-based rubber)	Green

④ Buffer specifications

JB	Rotating, With bushing
KB	Non-rotating, With bushing

⑥ Connection thread and type

Mounting	Type	Symbol	Size	Cup diameter	
				ø32 to ø50	ø63 to ø100
Direct mounting	Male thread	A10	M10 x 1.0	●	—
		A16	M16 x 1.5	—	●
		AG02	G1/4	●	●
	Female thread	BG02	G1/4	●	●
		BG03	G3/8	●	●
		S32	□31.8	●	●

* The adapter and cup are adhered to each other and cannot be disassembled.

Specifications

Cup Material

Material	FS61 (Fluoro-based rubber)
Color of rubber	Green
Rubber hardness (Shore A: ±5°)	65
Operating temperature range*1	0°C to 200°C
Ambient temperature	0°C to 150°C

*1 Surface temperature of the workpiece to be adsorbed

Adapter Specifications

Connection	Male thread		Female thread	Square adapter
Cup diameter	ø32 to ø50	ø63 to ø100	ø32 to ø100	ø32 to ø100
Size	M10 x 1.0 G1/4	M16 x 1.5 G1/4	G1/4 G3/8	□31.8
Vacuum inlet	Use the connection thread and type.			

Buffer Specifications

Non-rotating specification	Cup diameter		ø32 to ø50			ø63 to ø100		
	Stroke [mm]		10	30	50	10	30	50
JB Rotating, With bushing	Connection thread		M18 x 1.5			M22 x 1.5		
	Spring reactive force [N]	At 0 stroke	5.0			10.0		
		At full stroke	6.5	8.5	10.5	11.5	13.5	15.5
KB Non-rotating, With bushing	Connection thread		M22 x 1.5			M26 x 1.5		
	Spring reactive force [N]	At 0 stroke	5.0			10.0		
		At full stroke	7.0	9.0	11.0	13.5	15.5	17.5

Cup Specifications

Part no.	Horizontal holding force [N]*1		Minimum curvature radius for adsorption [mm]*2
	Without oil	With oil	
ZP3M-T32RBFS	35.8	18.0	12.5
ZP3M-T40RBFS	37.5	25.2	17.5
ZP3M-T50RBFS	63	46	27.5
ZP3M-T63RBFS	86	59	27.5
ZP3M-T80RBFS	122	91	34
ZP3M-T100RBFS	184.1	149.1	60

*1 These are actual measurement values when flat workpieces were adsorbed at a setting vacuum pressure of -60 kPa; however, they are not guaranteed values. (According to SMC's tests)
The values vary depending on the conditions (shape, surface roughness, oil type, oil amount, and other conditions) of the workpiece.

*2 These are actual measurement values when cylindrical workpieces were adsorbed at a setting vacuum pressure of -85 kPa; however, they are not guaranteed values. (According to SMC's tests)

Mesh Filter Specifications

Mesh filter	60
Opening	250 μm

Buffer assembly part no. p. 19

* The mounting nut is shipped together with the product (unassembled).

ZP3M Series

Dimensions/Models

With adapter Direct mounting type (Male thread)

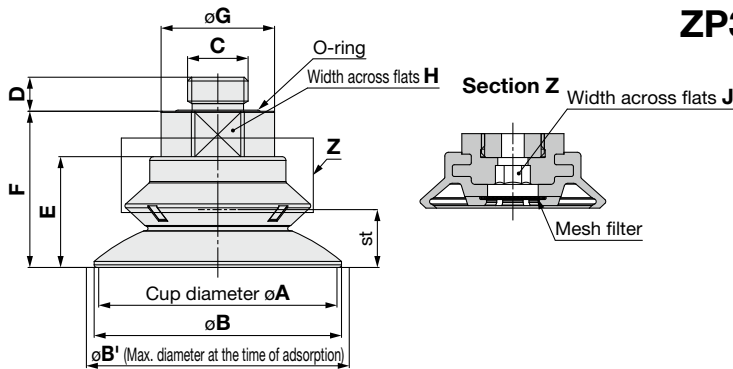

ZP3M - T **63** RB **FS** - **A16** - **MF**

① ② ③ ④



		Cup diameter [mm]	
		ø32 to ø50	ø63 to ø100
A10	M10 x 1.0	○	—
A16	M16 x 1.5	—	○
AG02	G1/4	○	○

Model							A	B	B ¹ *2	C	D	E	F	G	H	J	st*2	Min. opening hole size of the adapter	Weight [g]
Vacuum inlet direction	① Cup diameter	Form	② Material *1	③ Connection thread	④ Mesh filter														
ZP3M	T	RB	FS	A10	Nil MF	32	34	34.9	M10 x 1.0	7	19	28	22	19	5	9	ø5	29.9	
				G1/4					6.5	31.7									
				40		41.8	43.9	M10 x 1.0	7	19.8	28.8	22	19	5	10	ø5	31.4		
								G1/4	6.5								33.1		
				50		52.4	55.6	M10 x 1.0	7	24.9	36.9	30	27	8	11.8	ø5	68.6		
								G1/4	6.5								70.3		
				63		65.4	69.5	M16 x 1.5	9	29.3	41.3	30	27	8	15.2	ø6	86.3		
								G1/4	6.5								80.1		
				80		82.6	87.5	M16 x 1.5	9	37.9	49.9	30	27	8	22.1	ø6	119.3		
								G1/4	6.5								113.1		
				100		103	107.1	M16 x 1.5	9	44.6	56.6	30	27	8	25.8	ø6	166.5		
								G1/4	6.5								160.4		

*1 FS: FS61 (Fluoro-based rubber)

*2 B': Maximum cup diameter at the time of adsorption, st: The stroke is a guide value at the setting vacuum pressure of -90 kPa.

Dimensions/Models

With adapter Direct mounting type (Female thread)

ZP3M - T **63** **RB** **FS** - **BG02** - **MF**

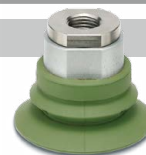

Connection thread: **BG02**

$\phi 32, \phi 40$

$\phi 50$ to $\phi 100$

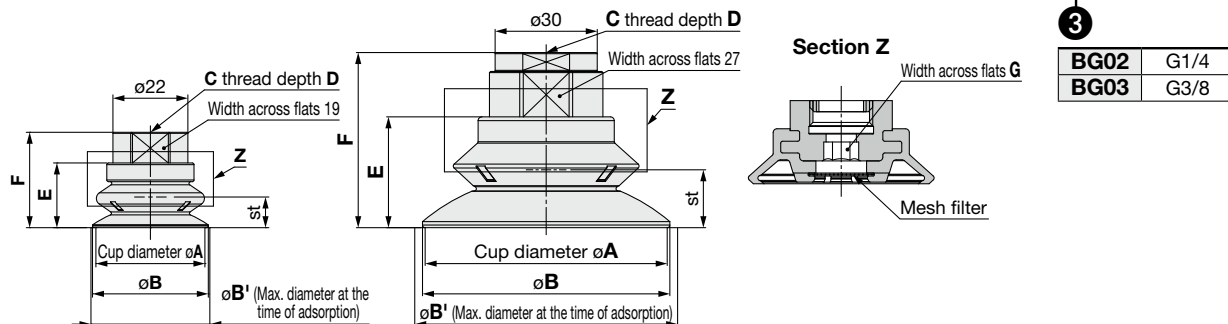

Connection thread: **BG03**

$\phi 32, \phi 40$

$\phi 50$ to $\phi 100$

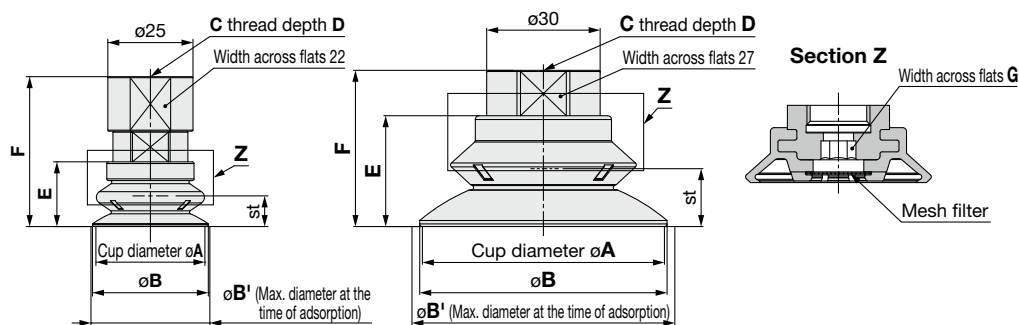

Model							A	B	B ^{*2}	C	D	E	F	G	st ^{*2}	Min. opening hole size of the adapter	Weight [g]
Vacuum inlet direction	① Cup diameter	Form	② Material ^{*1}	③ Connection thread	④ Mesh filter												
ZP3M	T	RB	FS	BG02	Nil MF	32	34	34.9	G1/4	11.0	19	28.0	5	9	10	11.8	17.5
				BG03					11.4	44.0							
				BG02					11.0	28.8							
				BG03					11.4	44.8							
				BG02					12.5	41.9							
				BG03					11.4	36.9							
	T	RB	FS	BG02	Nil MF	50	52.4	55.6	G1/4	12.5	24.9	46.3	8	15.2	22.1	25.8	111.9
				BG03					11.4	41.3							
				BG02					12.5	54.9							
				BG03					11.4	49.9							
				BG02					12.5	61.6							
				BG03					11.4	56.6							

*1 FS: FS61 (Fluoro-based rubber)

*2 B': Maximum cup diameter at the time of adsorption, st: The stroke is a guide value at the setting vacuum pressure of -90 kPa.

ZP3M Series

Dimensions/Models

With adapter Direct mounting type (Square adapter)

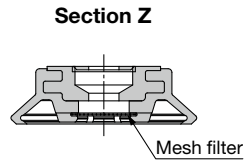
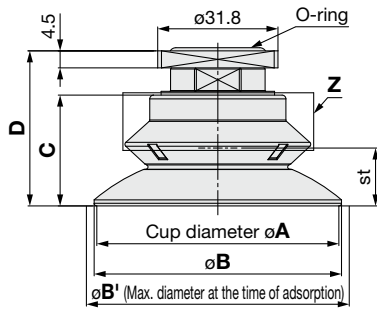

ZP3M - T **1** **2** **3** **63** RB **FS** - S32 - **MF**



	Vacuum inlet direction	Model					A	B	B ¹ *2	C	D	st*2	Min. opening hole size of the adapter	Weight [g]
		1 Cup diameter	Form	2 Material *1	Connection thread	3 Mesh filter								
ZP3M	T	32	RB	FS	S32	Nil MF	32	34	34.9	19	31.2	9	ø5	30.2
		40					40	41.8	43.9	19.8	32	10		31.6
		50					50	52.4	55.6	24.9	36.6	11.8	ø8	50.0
		63					63	65.4	69.5	29.3	41	15.2		59.8
		80					80	82.6	87.5	37.9	49.6	22.1		92.8
		100					100	103	107.1	44.6	56.3	25.8		140.0

*1 FS: FS61 (Fluoro-based rubber)

*2 B': Maximum cup diameter at the time of adsorption, st: The stroke is a guide value at the setting vacuum pressure of -90 kPa.

Square adapter mounting groove dimensions (Recommended)

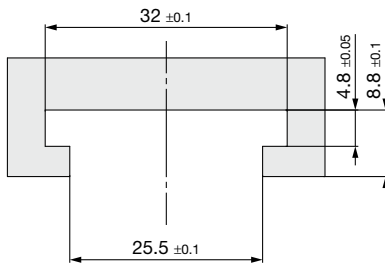

* For details on how to use the square adapter, refer to "Mounting" on page 26.

Dimensions/Models

With buffer Plate mounting type (Vacuum inlet direction: Vertical)

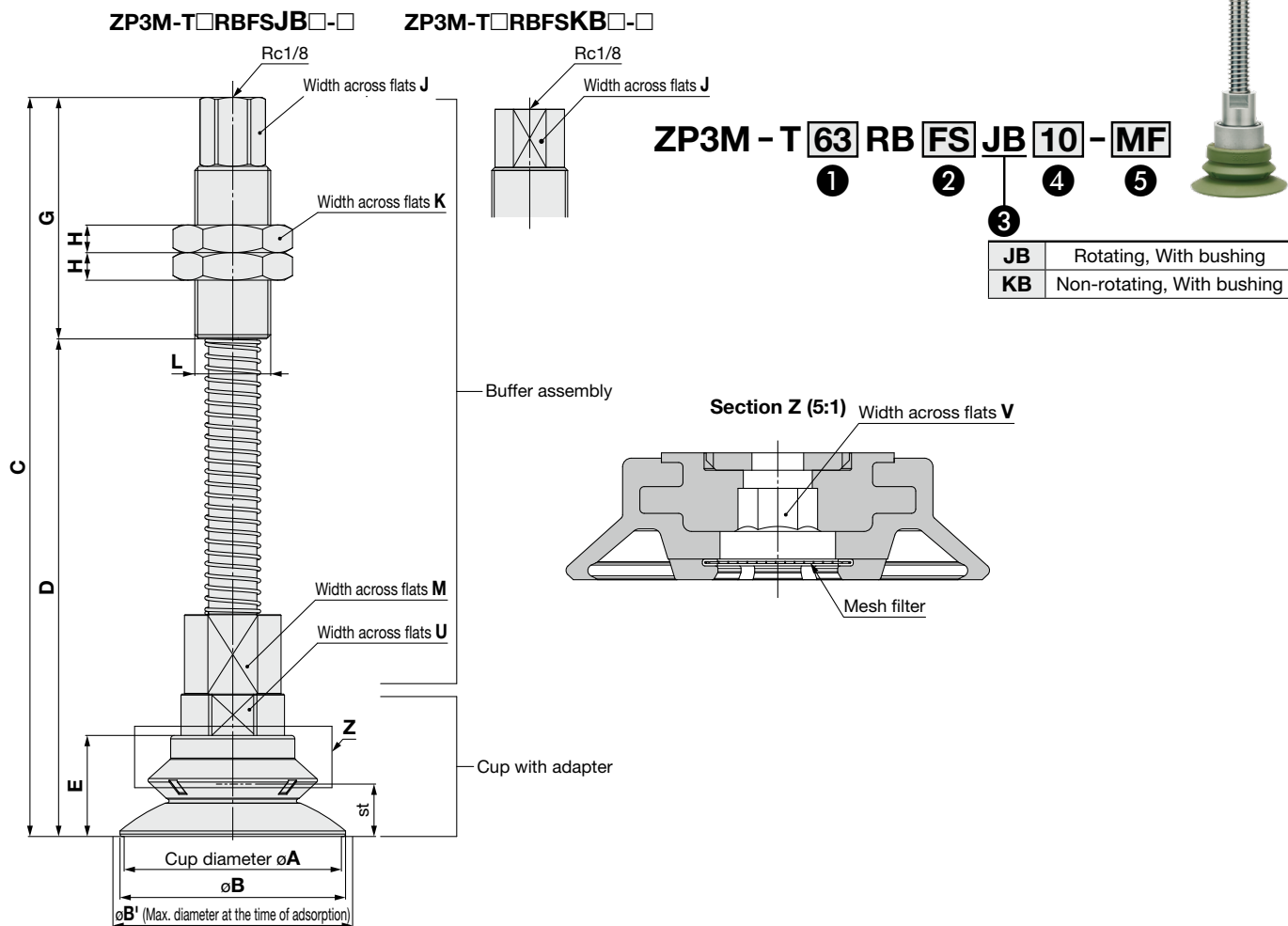

Vacuum inlet direction		Model					A	B	B ¹ *2	C	D	E	G	H				L		M	U	V	st ^{*2}	Min. opening hole size	Weight [g]								
		1	2	3	4	5								JB	KB	JB	KB	JB	KB														
		Cup diameter	Form	Material *1	Buffer spec.	Buffer stroke								Mesh filter	JB	KB	JB	KB	JB						KB								
ZP3M	T	32	RB	FS	JB	KB	10	Nil	MF	32	34	34.9	127.5	75.5	19	35	11	14	18	27	30	M18 x 1.5	M22 x 1.5	16	19	5	10	ø3	9	221.0	262.2		
																														30	235.5	288.2	
																														50	246.9	308.1	
																														10	222.4	263.7	
																														30	236.9	289.7	
																														50	248.3	309.5	
			40	RB	FS	JB	KB	10	Nil	MF	40	41.8	43.9	153.3	101.3	19.8	35	11	14	18	27	30	M18 x 1.5	M22 x 1.5	16	19	5	10	ø3	11.8	259.7	300.9	
																															30	274.2	326.9
																															50	285.6	346.8
																															10	259.7	300.9
																															30	274.2	326.9
																															50	285.6	346.8
		50	RB	FS	JB	KB	10	Nil	MF	50	52.4	55.6	161.4	109.4	24.9	50	8	17	21	30	32	M22 x 1.5	M26 x 1.5	24	27	8	15.2	ø4	22.1	399.1	435.9		
																														30	427.9	472.0	
																														50	450.8	499.6	
																														10	432.2	468.9	
																														30	460.9	505.0	
																														50	483.9	532.7	
		63	RB	FS	JB	KB	10	Nil	MF	63	65.4	69.5	194.3	124.3	29.3	50	8	17	21	30	32	M22 x 1.5	M26 x 1.5	24	27	8	15.2	ø4	22.1	479.4	516.2		
																														30	508.2	552.2	
																														50	531.1	579.9	
																														10	479.4	516.2	
																														30	508.2	552.2	
																														50	531.1	579.9	
80	RB	FS	JB	KB	10	Nil	MF	80	82.6	87.5	202.9	132.9	37.9	50	8	17	21	30	32	M22 x 1.5	M26 x 1.5	24	27	8	22.1	ø4	25.8	479.4	516.2				
																												30	508.2	552.2			
																												50	531.1	579.9			
																												10	479.4	516.2			
																												30	508.2	552.2			
																												50	531.1	579.9			
100	RB	FS	JB	KB	10	Nil	MF	100	103	107.1	209.6	139.6	44.6	50	8	17	21	30	32	M22 x 1.5	M26 x 1.5	24	27	8	22.1	ø4	25.8	479.4	516.2				
																												30	508.2	552.2			
																												50	531.1	579.9			
																												10	479.4	516.2			
																												30	508.2	552.2			
																												50	531.1	579.9			

*1 FS: FS61 (Fluoro-based rubber)

*2 B': Maximum cup diameter at the time of adsorption, st: The stroke is a guide value at the setting vacuum pressure of -90 kPa.

ZP3M Series

Dimensions/Models

With buffer Plate mounting type (Vacuum inlet direction: Lateral)

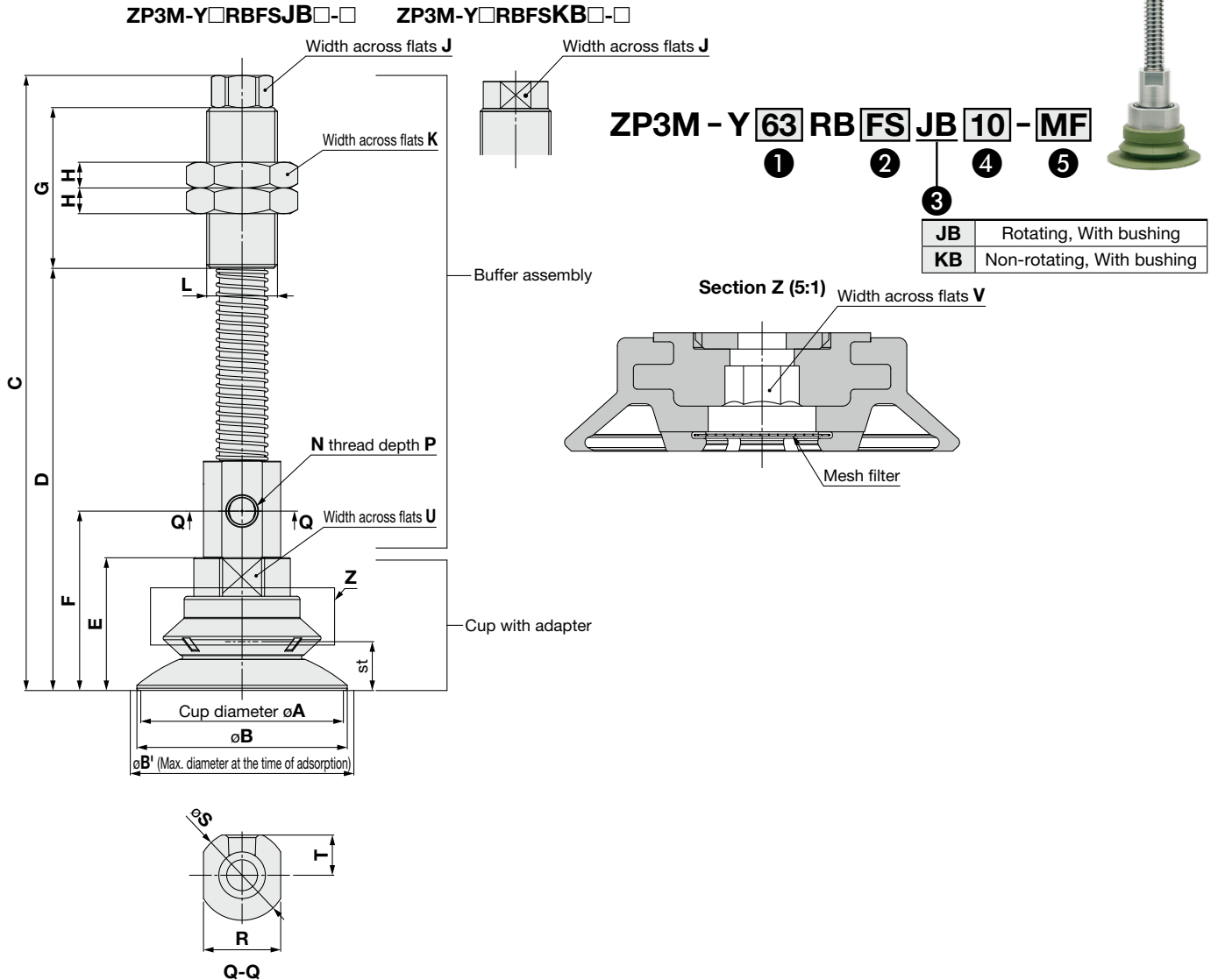

Model		1	2	3	4	5	A	B	B' _{※2}	C	D	E	F	G	H	J	K	L		N	P	R	S	T	U	V	st _{※2}	Min. opening hole size	Weight [g]			
Vacuum inlet direction	Cup diameter	Form	Material _{※1}	Buffer spec.	Buffer stroke	Mesh filter									JB	KB	JB	KB	JB	KB										JB	KB	
ZP3M	Y	RB	FS	JB	10	Nil	MF	32	34	34.9	122.5	78.5	19	37.9	11	14	18	27	30	M18 x 1.5	M22 x 1.5	M5 x 0.8	5	16	19	8.5	19	5	10	ø5	219.4	251.9
					30						147.5	103.5																			235.2	279.3
					50						167.5	123.5																			247.8	300.3
					10						123.3	79.3																			220.8	253.3
					30						148.3	104.3																			236.7	280.7
					50						168.3	124.3																			249.2	301.7
	63	50	52.4	55.6	10	131.4	87.4	24.9	46.8	11.8	258.0	290.6																				
					30	156.4	112.4				273.9	318.0																				
					50	176.4	132.4				286.5	339.0																				
					10	166.3	106.3				400.3	422.8																				
					30	191.3	131.3				431.5	461.4																				
					50	211.3	151.3				456.4	491.1																				
80	50	82.6	87.5	10	174.9	114.9	29.3	55.8	8	258.0	290.6																					
				30	199.9	139.9				273.9	318.0																					
				50	219.9	159.9				286.5	339.0																					
				10	181.6	121.6				400.3	422.8																					
				30	206.6	146.6				431.5	461.4																					
				50	226.6	166.6				456.4	491.1																					
100	50	103	107	10	181.6	121.6	44.6	71.1	8	258.0	290.6																					
				30	206.6	146.6				273.9	318.0																					
				50	226.6	166.6				286.5	339.0																					
				10	181.6	121.6				400.3	422.8																					
				30	206.6	146.6				431.5	461.4																					
				50	226.6	166.6				456.4	491.1																					

*1 FS: FS61 (Fluoro-based rubber)

*2 B': Maximum cup diameter at the time of adsorption, st: The stroke is a guide value at the setting vacuum pressure of -90 kPa.

Construction

With adapter

ZP3M-T□RBFS-A□

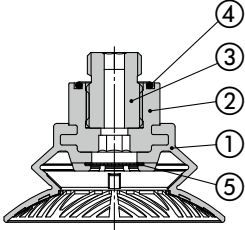

ZP3M-T (32, 40) RBFS-BG02

ZP3M-T□RBFS-S32

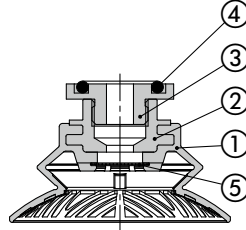

ZP3M-T (50, 63, 80, 100) RBFS-BG02

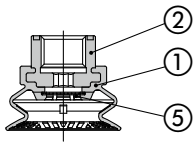

ZP3M-T (32, 40) RBFS-BG03

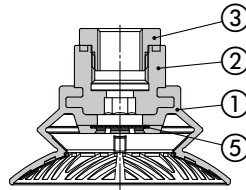

ZP3M-T (50, 63, 80, 100) RBFS-BG03

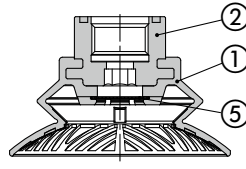
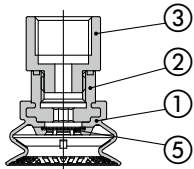

With buffer

ZP3M-T□RBFS(JB/KB)□-□

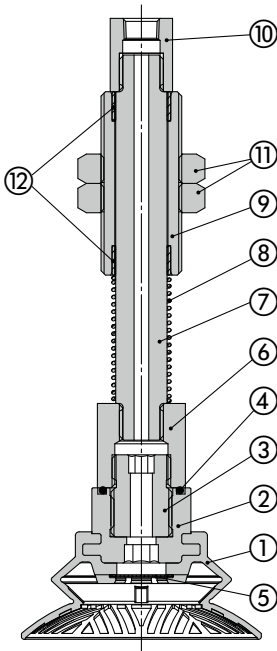

ZP3M-Y□RBFS(JB/KB)□-□

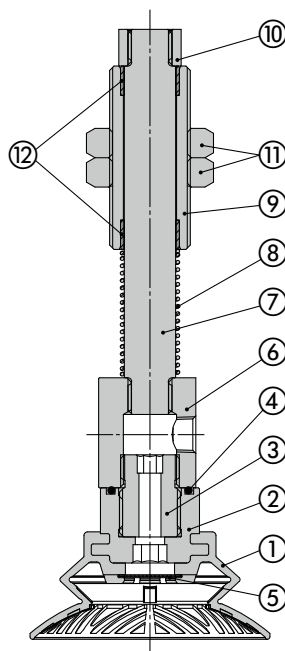

Component Parts

No.	Description	Material	Note
1	Cup	FS61 (Fluoro-based rubber)	—
2	Insert adapter	Aluminum alloy	—
3	Adapter	Structural carbon steel (Electroless nickel plating)	ZP3M-T (32, 40) RBFS-A□ ZP3M-T (50, 63, 80, 100) RBFS- (A□, BG02)
		Aluminum alloy (Anodized)	ZP3M-T (32, 40) RBFS-BG03 ZP3M-T□RBFS-S32
4	O-ring	FKM	—
5	Mesh filter	Stainless steel	—

* The parts 1, 2, and 3 are adhered to each other and cannot be disassembled.

Component Parts

No.	Description	Material	Note
1	Cup	FS61 (Fluoro-based rubber)	—
2	Insert adapter	Aluminum alloy	—
3	Adapter	Structural carbon steel (Electroless nickel plating)	—
4	O-ring	FKM	—
5	Mesh filter	Stainless steel	—
6	Adapter	Aluminum alloy (Anodized)	—
7	Piston rod	Structural steel (Hard chrome plating)	ZP3M-(T,Y)□RBFSJB□-□
		Stainless steel	ZP3M-(T,Y)□RBFSKB□-□
8	Return spring	Stainless steel	—
9	Buffer body	Brass (Electroless nickel plating)	—
10	Buffer adapter	Brass (Electroless nickel plating)	—
11	Nut	Steel (Zinc chromated)	M18 x 1.5
		Structural steel (Nickel plating)	M22 x 1.5
		Structural carbon steel (Nickel plating)	M26 x 1.5
12	Bushing	—	—

* The parts 1, 2, and 3 are adhered to each other and cannot be disassembled.

Replacement Parts: Mesh Filter Unit

Part no.	Cup diameter	
	ø32 to ø50	ø63 to ø100
ZPMF-60-D13	●	—
ZPMF-60-D18	—	●



ZP3M Series

Mounting Bracket Assembly

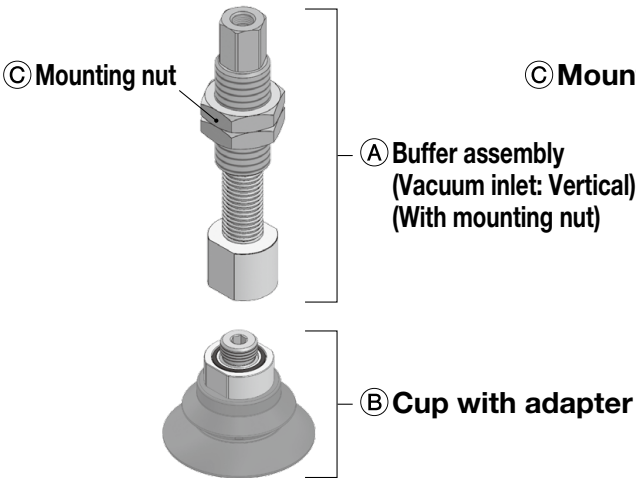
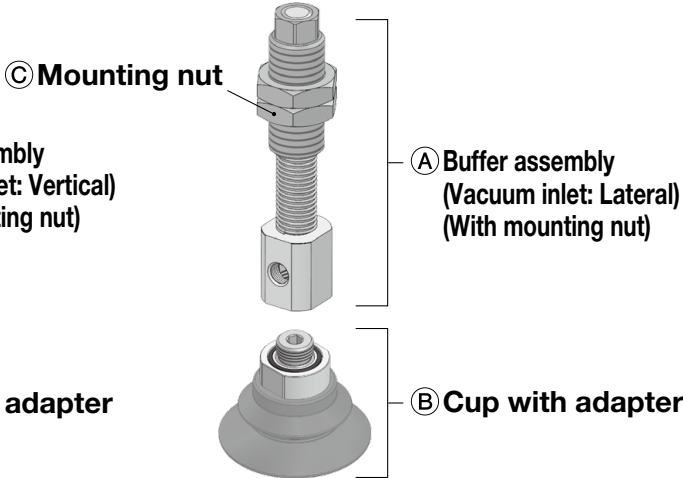
Product part no.	<p style="text-align: center;">ZP3M - (T/Y) ① RB FS ②(JB/KB) ③ - □</p> <p>T: Vertical vacuum inlet Y: Lateral vacuum inlet</p> <p>① Cup diameter</p> <p>② Cup material</p> <p>③ Mesh filter</p> <p>Buffer stroke</p> <p>JB: Rotating, With bushing KB: Non-rotating, With bushing</p>	
Component parts	<p>ZP3M-T□RBFS(JB/KB)□-□</p> 	<p>ZP3M-Y□RBFS(JB/KB)□-□</p> 

		Symbol	① Cup diameter						
			32	40	50	63	80	100	
Ⓐ Buffer assembly (With mounting nut)	③ Buffer stroke	10	ZP3EB-(T/Y)1(JB/KB)10			ZP3EB-(T/Y)2(JB/KB)10			
		30	ZP3EB-(T/Y)1(JB/KB)30			ZP3EB-(T/Y)2(JB/KB)30			
		50	ZP3EB-(T/Y)1(JB/KB)50			ZP3EB-(T/Y)2(JB/KB)50			
Ⓑ Cup with adapter		M10 x 1.0	ZP3M-T(32/40/50)RBFS-A10-□			-			
		M16 x 1.5	-			ZP3M-T(63/80/100)RBFS-A16-□			
Ⓒ Mounting nut (Single unit)	② Buffer specifications	JB	M18 x 1.5	ZPNA-M18			-		
			M22 x 1.5	-			ZPNA-M22		
		KB	M22 x 1.5	ZPNA-M22			-		
			M26 x 1.5	-			ZPNA-M26		

[Buffer assembly part number example]

Product part no. **ZP3M - T63RBFS JB 10**

Buffer assembly **ZP3EB - T2 JB 10**

② Buffer stroke

Suction Cup/ Oval Flat Shape with Non-slip Feature ZP3M Series

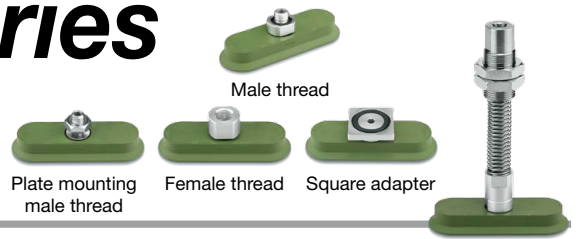

How to Order

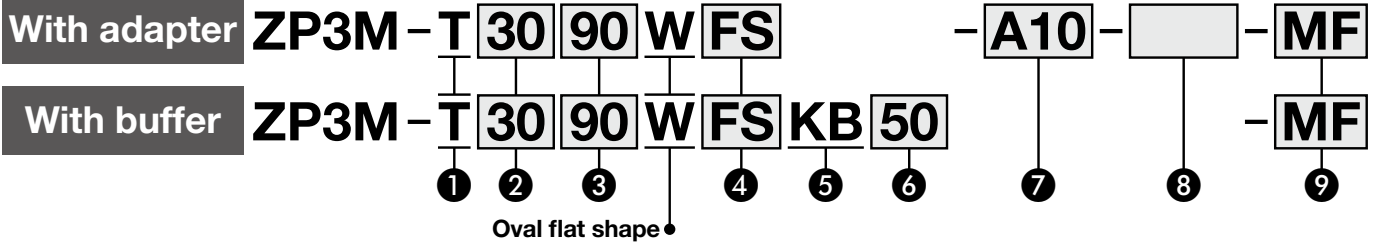

① Vacuum inlet direction

T	Vertical
----------	----------

② ③ Cup size

Symbol	③ Length			
	50	90	80	100
② Breadth	16	● (16 x 50)	-	-
	30	-	● (30 x 90)	-
	40	-	-	● (40 x 80)
	50	-	-	● (50 x 100)

⑦ Connection thread / ⑧ Vacuum inlet

Mounting	Connection thread			Vacuum inlet			Cup size
	Type	Symbol	Size	Type	Symbol	Size	
Direct mounting	Male thread	A10	M10 x 1.0	-	Nil	Use the connection thread.	16 x 50, 30 x 90
		A16	M16 x 1.5				40 x 80, 50 x 100
	Female thread	BG02	G1/4				All sizes
		BG03	G3/8				
Square adapter	S32	□31.8					
	Male thread	A10	M10 x 1.5	Female thread	B5	M5 x 0.8	
		A14	M14 x 1.5		B01	Rc1/8	
AG02	G1/4	B01	Rc1/8				

* The adapter and cup are adhered to each other and cannot be disassembled.

Specifications

Cup Material

Material	FS61 (Fluoro-based rubber)
Color of rubber	Green
Rubber hardness (Shore A: ±5°)	65
Operating temperature range*1	0°C to 200°C
Ambient temperature	0°C to 150°C

*1 Surface temperature of the workpiece to be adsorbed

Adapter Specifications

Mounting	Direct mounting				Plate mounting
	Male thread		Female thread	Square adapter	Male thread
Connection	Male thread		Female thread	Square adapter	Male thread
Cup diameter	16 x 50, 30 x 90	40 x 80, 50 x 100	All sizes	All sizes	All sizes
Size	M10 x 1.0	M16 x 1.5	G1/4 G3/8	□31.8	M10 x 1.5 M14 x 1.5 G1/4
Vacuum inlet	Use the connection thread.				M5 x 0.8 Rc1/8

Buffer Specifications

Non-rotating specification	Cup diameter			16 x 50, 30 x 90			40 x 80, 50 x 100			
	Stroke [mm]			10	30	50	10	30	50	
KB Non-rotating, With bushing	Connection thread			M22 x 1.5			M26 x 1.5			
	Spring reactive force [N]	At 0 stroke			5.0			10.0		
		At full stroke			7.0	9.0	11.0	13.5	15.5	17.5

Cup Specifications

Part no.	Horizontal holding force [N]*1, *2		Minimum curvature radius for adsorption [mm]*3
	Without oil	With oil	
ZP3M-T1650WFS	42	10	10
ZP3M-T3090WFS	160	42	42
ZP3M-T4080WFS	174	59	46
ZP3M-T50100WFS	267	105	65

*1 These are actual measurement values when flat workpieces were adsorbed at a setting vacuum pressure of -60 kPa; however, they are not guaranteed values. (According to SMC's tests)

The values vary depending on the conditions (shape, surface roughness, oil type, oil amount, and other conditions) of the workpiece.

*2 The horizontal holding force in the breadth and length directions is the same.

*3 These are actual measurement values when cylindrical workpieces were adsorbed at a setting vacuum pressure of -85 kPa; however, they are not guaranteed values. (According to SMC's tests)

Mesh Filter Specifications

Mesh filter	60
Opening	250 μm

Buffer assembly part no. p. 25

* The mounting nut is shipped together with the product (unassembled).

ZP3M Series

Dimensions/Models

With adapter Direct mounting type (Male thread)

ZP3M - T **3090** W **FS** - **A10** - **MF**



	Connection thread (Male thread)	Cup size	
		16 x 50, 30 x 90	40 x 80, 50 x 100
A10	M10 x 1.0	○	-
A16	M16 x 1.5	-	○

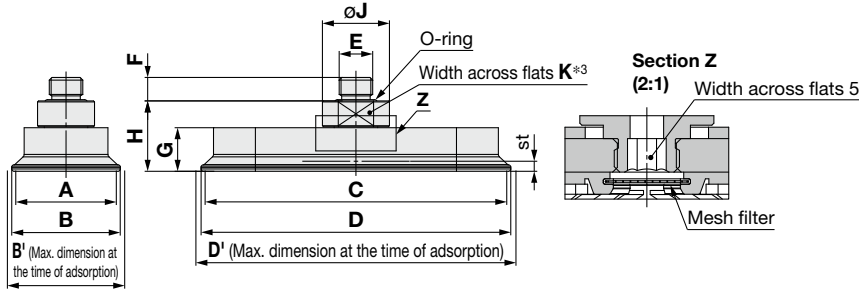

		Model						A	B	B ^{*2}	C	D	D ^{*2}	E	F	G	H	J	K	st ^{*2}	Min. opening hole size of the adapter	Weight [g]	
	Vacuum inlet direction	① Cup size	Form	② Material ^{*1}	③ Connection thread	④ Mesh filter																	
ZP3M	T	1650	W	FS	A10	Nil	16	18	19	50	52	53.3	M10 x 1.0	7	17.3	25.5	20	17	3	ø5	24.0		
		3090					30	32.4	35	90	92.4	95.5									13	21	48.5
		4080					40	42.4	45.2	80	82.4	85.5			14	24					54.2		
		50100					50	52.6	56.1	100	102.6	106.7									16	26	89.1

*1 FS: FS61 (Fluoro-based rubber)

*2 B', D': Maximum cup diameter at the time of adsorption, st: The stroke is a guide value at the setting vacuum pressure of -90 kPa.

*3 The direction of width across flats K varies depending on the product.

With adapter Direct mounting type (Female thread)

ZP3M - T **3090** W **FS** - **BG02** - **MF**

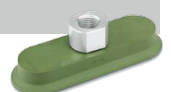

③ Connection thread (Female thread)

BG02	G1/4
BG03	G3/8

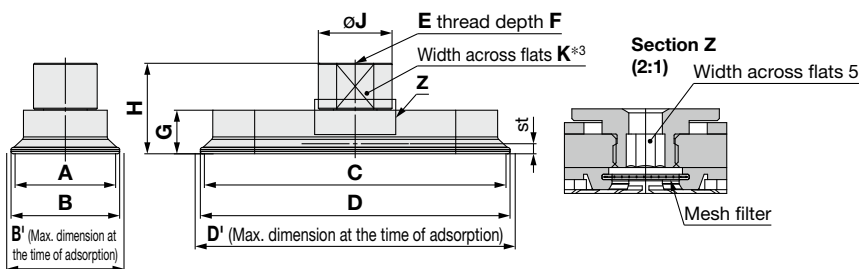

		Model						A	B	B ^{*2}	C	D	D ^{*2}	E	F	G	H	J	K	st ^{*2}	Min. opening hole size of the adapter	Weight [g]														
	Vacuum inlet direction	① Cup size	Form	② Material ^{*1}	③ Connection thread	④ Mesh filter																														
ZP3M	T	1650	W	FS	BG02	Nil	16	18	19	50	52	53.3	G1/4	8	17.3	31.5	22	19	3	ø5	27.4															
													G3/8	9							32.5	25	22	29.9												
		3090											BG02	30	32.4	35	90	92.4			95.5	G1/4	8	13	27	22	19	28	25	22	4	54.4				
																						G3/8	9										28	22	19	45.9
		4080											BG02	40	42.4	45.2	80	82.4			85.5	G1/4	8	14	28	22	19	29	25	22			5	80.7		
																						G3/8	9												29	25
		50100											BG02	50	52.6	56.1	100	102.6			106.7	G1/4	8	16	30	22	19	30	22	19					5	83.3
																						G3/8	9													

*1 FS: FS61 (Fluoro-based rubber)

*2 B', D': Maximum cup diameter at the time of adsorption, st: The stroke is a guide value at the setting vacuum pressure of -90 kPa.

*3 The direction of width across flats K varies depending on the product.

Dimensions/Models

With adapter Direct mounting type (Square adapter)

ZP3M - T **3090** W **FS** - S32 - **MF**

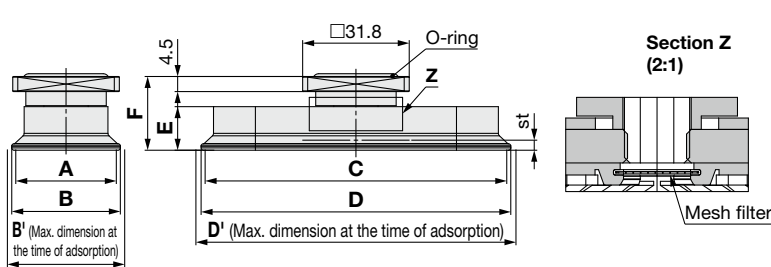

Model							A	B	B ^{1*2}	C	D	D ^{1*2}	E	F	st ^{*2}	Min. opening hole size of the adapter	Weight [g]
Vacuum inlet direction	① Cup size	Form	② Material *1	Connection thread	③ Mesh filter												
ZP3M	T	W	FS	S32	Nil MF	1650	16	18	19	50	52	53.3	17.3	26.5	3	ø5	34.0
						3090	30	32.4	35	90	92.4	95.5	13	22			58.5
						4080	40	42.4	45.2	80	82.4	85.5	14	23			52.4
						50100	50	52.6	56.1	100	102.6	106.7	16	25	87.3		

*1 FS: FS61 (Fluoro-based rubber)

*2 B¹, D¹: Maximum cup diameter at the time of adsorption, st: The stroke is a guide value at the setting vacuum pressure of -90 kPa.

Square adapter mounting groove dimensions (Recommended)

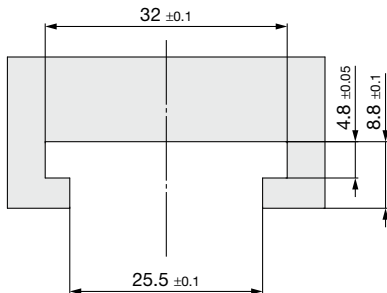

* For details on how to use the square adapter, refer to "Mounting" on page 26.

With adapter Plate mounting type (Male thread)

ZP3M - T **3090** W **FS** - **A10** - **B5** - **MF**

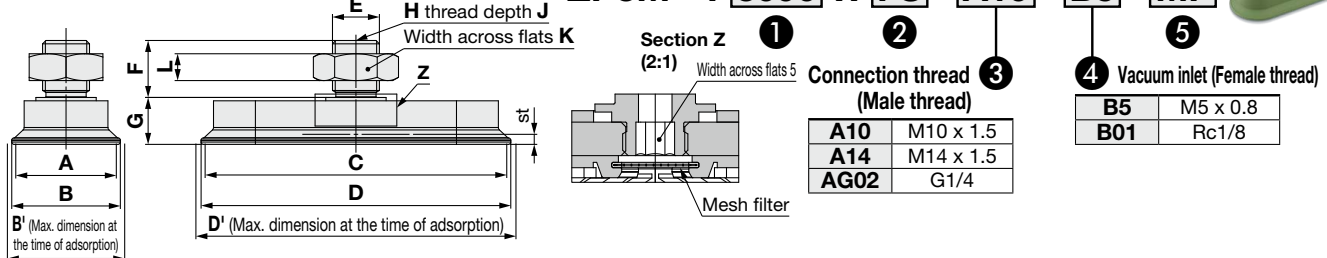

Model							A	B	B ^{1*2}	C	D	D ^{1*2}	E	F	G	H	J	K	L	st ^{*2}	Min. opening hole size of the adapter	Weight [g]
Vacuum inlet direction	① Cup size	Form	② Material *1	③ Connection thread	④ Vacuum inlet	⑤ Mesh filter																
ZP3M	T	W	FS	A10 A14 AG02	B5 B01 B01	Nil MF	16	18	19	50	52	53.3	M10 x 1.5	15	18.5	M5 x 0.8	5	17	6	3	ø4.2	37.0
													M14 x 1.5	17		Rc1/8	6.2	22	8		ø5	54.1
													G1/4	13		Rc1/8	6.2	17	5		35.3	
													M10 x 1.5	15	14	M5 x 0.8	5	17	6		ø4.2	61.5
													M14 x 1.5	17		Rc1/8	6.2	22	8		ø5	78.6
													G1/4	13		Rc1/8	6.2	17	5		59.8	
							M10 x 1.5	15	15	M5 x 0.8	5	17	6	ø4.2	55.4							
							M14 x 1.5	17		Rc1/8	6.2	22	8	ø5	72.6							
							G1/4	13		Rc1/8	6.2	17	5	53.8								
							50	52.6	56.1	100	102.6	106.7	106.7	M10 x 1.5	15	17	M5 x 0.8	5	17	6	ø4.2	90.3
														M14 x 1.5	17		Rc1/8	6.2	22	8	ø5	107.5
														G1/4	13		Rc1/8	6.2	17	5	88.6	

*1 FS: FS61 (Fluoro-based rubber)

*2 B¹, D¹: Maximum cup diameter at the time of adsorption, st: The stroke is a guide value at the setting vacuum pressure of -90 kPa.

ZP3M Series

Dimensions/Models

With buffer Plate mounting type (Vacuum inlet direction: Vertical)

ZP3M - T **4080** W **FS** **KB** **50** - **MF**

① ② ③ ④ ⑤

3 Buffer specifications
KB Non-rotating, With bushing

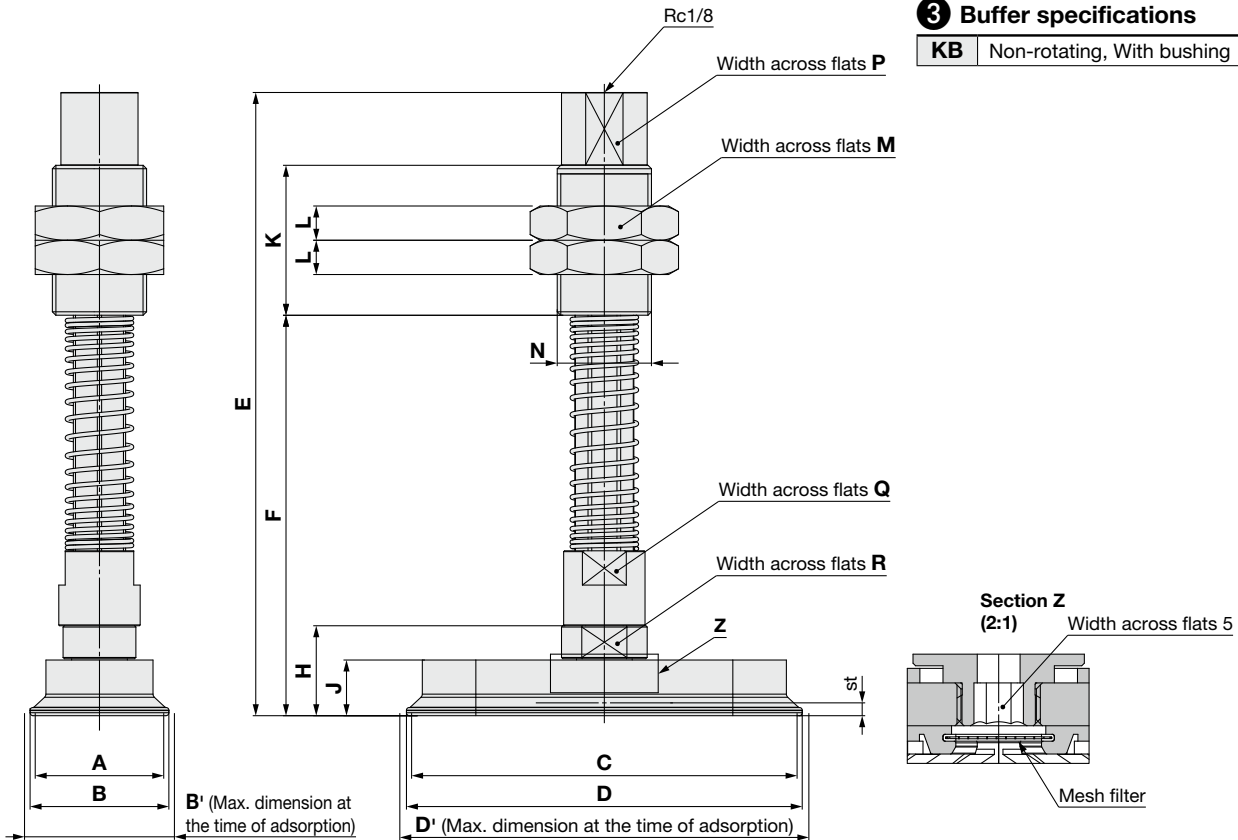

Model							A	B	B ¹ *2	C	D	D ¹ *2	E	F	H	J	K	L	M	N	P	Q	R	st*2	Min. opening hole size	Weight [g]
Vacuum inlet direction	① Cup size	Form	② Material *1	③ Buffer spec.	④ Buffer stroke	⑤ Mesh filter																				
ZP3M	T	W	FS	KB	10	Nil	16	18	19	50	52	53.3	125	73	25.5	17.3	35	30	M22 x 1.5	18	16	17	3	ø3	256.3	
													150	98											282.3	
													170	118											302.1	
													120.5	68.5											280.8	
													145.5	93.5											306.8	
													165.5	113.5											326.7	
	T	W	FS	KB	30	Nil	30	32.4	35	90	92.4	95.5	152	82	21	13	8	30	M22 x 1.5	18	16	17	3	ø3	403.9	
													177	107											439.9	
													197	127											467.6	
													154	84											438.7	
													179	109											474.8	
													199	129											502.5	
T	W	FS	KB	50	Nil	40	42.4	45.2	80	82.4	85.5	152	82	24	14	50	32	M26 x 1.5	21	24	24	4	ø4	403.9		
												177	107											439.9		
												197	127											467.6		
												154	84											438.7		
												179	109											474.8		
												199	129											502.5		
T	W	FS	KB	50	Nil	50	52.6	56.1	100	102.6	106.7	152	82	26	16	50	32	M26 x 1.5	21	24	24	5	ø4	403.9		
												177	107											439.9		
												197	127											467.6		
												154	84											438.7		
												179	109											474.8		
												199	129											502.5		

*1 FS: FS61 (Fluoro-based rubber)

*2 B', D': Maximum cup diameter at the time of adsorption, st: The stroke is a guide value at the setting vacuum pressure of -90 kPa.

Construction

With adapter

ZP3M-T□WFS-A□

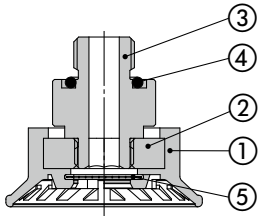

ZP3M-T□WFS-A□-B□

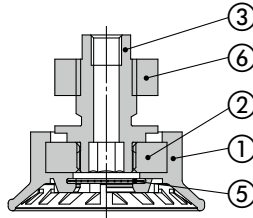

ZP3M-T□WFS-B□

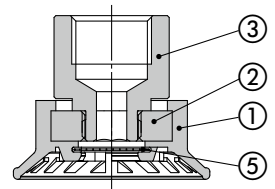

ZP3M-T□WFS-S32

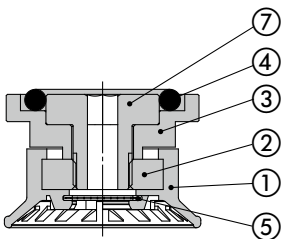

Component Parts

No.	Description	Material	Note
1	Cup	FS61 (Fluoro-based rubber)	-
2	Insert plate	Aluminum alloy	
3	Adapter	Aluminum alloy (Anodized)	ZP3M-T□WFS-A□ ZP3M-T□WFS-B□ ZP3M-T□WFS-S32
		Structural carbon steel (Electroless nickel plating)	ZP3M-T□WFS-A□-B□
4	O-ring	FKM	-
5	Mesh filter	Stainless steel	
6	Nut	Steel (Zinc chromated)	ZP3M-T□WFS-A10-B□ ZP3M-T□WFS-A14-B□
		Brass (Electroless nickel plating)	ZP3M-T□WFS-AG02-B□
7	Set screw	Aluminum alloy (Anodized)	-

* The parts 1, 2, and 3 are adhered to each other and cannot be disassembled.

With buffer

ZP3M-T□WFSKB□-□

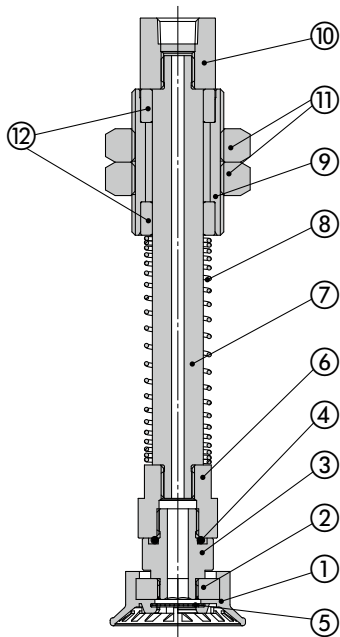

Component Parts

No.	Description	Material	Note
1	Cup	FS61 (Fluoro-based rubber)	-
2	Insert plate	Aluminum alloy	
3	Adapter	Structural carbon steel (Electroless nickel plating)	
4	O-ring	FKM	
5	Mesh filter	Stainless steel	
6	Adapter	Aluminum alloy	
7	Piston rod	Structural steel (Hard chrome plating)	
8	Return spring	Stainless steel	
9	Buffer body	Brass (Electroless nickel plating)	
10	Buffer adapter	Brass (Electroless nickel plating)	
11	Nut	Structural steel (Nickel plating)	
12	Bushing	-	

* The parts 1, 2, and 3 are adhered to each other and cannot be disassembled.

Replacement Parts: Mesh Filter Unit

Part no.	Cup size
ZPMF-60-D13	30 x 90, 40 x 80, 50 x 100



* The mesh filter cannot be mounted on cup size 16 x 50.

Replacement Parts: Mounting Nut

Product part no.	Mounting nut part no.
ZP3M-T□WFS-A10-B5	ZPNA-M10A
ZP3M-T□WFS-A14-B01	ZPNA-M14B
ZP3M-T□WFS-AG02-B01	ZPNA-G02

ZP3M Series

Mounting Bracket Assembly

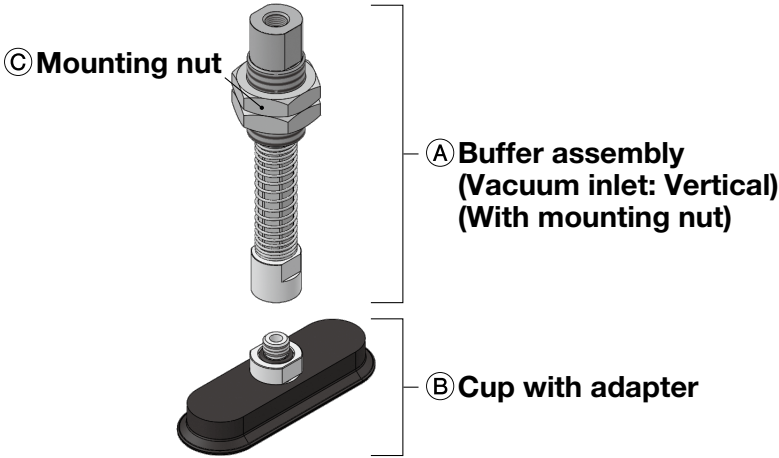
Product part no.	<p>ZP3M - T ① W FS KB ② - □</p> <p>T: Vertical vacuum inlet ●</p> <p>● Cup size</p> <p>● Buffer stroke</p> <p>● Cup material</p> <p>● Mesh filter</p>
Component parts	 <p>③ Mounting nut</p> <p>① Buffer assembly (Vacuum inlet: Vertical) (With mounting nut)</p> <p>② Cup with adapter</p>

		Symbol	① Cup size			
			1650	3090	4080	50100
① Buffer assembly (With mounting nut)	② Buffer stroke	10	ZP3EB-T1KB10		ZP3EB-T2KB10	
		30	ZP3EB-T1KB30		ZP3EB-T2KB30	
		50	ZP3EB-T1KB50		ZP3EB-T2KB50	
② Cup with adapter	M10 x 1.0	ZP3M-T(1650/3090)WFS-A10-□		-		
	M16 x 1.5	-		ZP3M-T(4080/50100)WFS-A16-□		
③ Mounting nut (Single unit)	M22 x 1.5	ZPNA-M22		-		
	M26 x 1.5	-		SN-032B		

[Buffer assembly part number example]

Product part no. **ZP3M - T4080WFS KB 10**

Buffer assembly **ZP3EB - T2 KB 10**

② Buffer stroke



ZP3M Series

Suction Cup/Specific Product Precautions

Be sure to read this before handling the products. Refer to the back cover for safety instructions. For vacuum equipment precautions, refer to the “Handling Precautions for SMC Products” and the “Operation Manual” on the SMC website: <https://www.smcworld.com>

Design

1. Before use, please check the transfer conditions with the customer’s actual equipment.

The transfer ability varies depending on the workpiece material, the friction between the cup and workpiece, moment, wind, vibration, etc. Testing with the customer’s actual equipment is necessary.

2. In cases where the workpieces are heavy or dangerous objects, etc., take measures to address a possible loss of adsorption force (installation of a drop prevention guide, etc.).

3. The oil, chemical, and other substances adhered to the workpiece may not be suitable for the cup material.

Before using this product, sufficiently verify the workpieces in your operating environment.

Mounting

1. When mounting the product, tighten with the tightening torque shown in the table below.

If excessive or insufficient tightening torque is applied, sealing failure or loose screws may result.

When using a product equipped with a buffer, if the buffer is tightened to a torque beyond the appropriate tightening torque range, the buffer may malfunction.

With Adapter (Male thread type)

Model	Connection thread size	Proper tightening torque [N·m]
ZP3M-T□(R, RB, W)FS-A10-□	M10 x 1.0	8 to 10
ZP3M-T□(R, RB, W)FS-A16-□	M16 x 1.5	13 to 15
ZP3M-T□(R, RB)FS-AG02-□	G1/4	8 to 12

With Adapter (Female thread type)

Model	Connection thread size	Proper tightening torque [N·m]
ZP3M-T□RFS-B14-□	M14 x 1.0	11 to 13
ZP3M-T□(R, RB, W)FS-BG02-□	G1/4	8 to 12
ZP3M-T□(R, RB, W)FS-BG03-□	G3/8	15 to 20

Plate Mounting: With Adapter (Male thread type)

Model	Connection thread size	Proper tightening torque [N·m]
ZP3M-T□WFS-A10-B5-□	M10 x 1.5	8 to 10
ZP3M-T□WFS-A14-B01-□	M14 x 1.5	11 to 13
ZP3M-T□WFS-AG02-B01-□	G1/4	8 to 12

With Buffer

Model	Connection thread size	Proper tightening torque [N·m]
ZP3M-(T/Y)□(R, RB)FSJB□-□	M18 x 1.5	28 to 32
	M22 x 1.5	45 to 50
ZP3M-(T/Y)□(R, RB)FSKB□-□	M22 x 1.5	45 to 50
	M26 x 1.5	62 to 68
ZP3M-T□WFSKB□-□	M22 x 1.5	45 to 50
	M26 x 1.5	62 to 68

Mounting

2. How to use the square adapter

Use the square adapter by inserting it to an attachment you prepare. If it is difficult to insert the square adapter, apply grease to the O-ring. Prepare retaining measures by yourself.

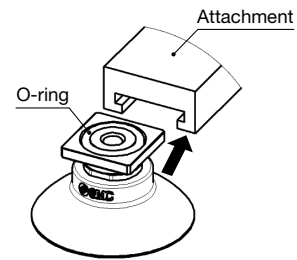

Handling

1. Depending on the type of oil or foreign matter, the mesh filter may be clogged at an early stage.

Before using this product, sufficiently verify the mesh filter in your operating environment.

2. Periodically inspect the mesh filter.

An adsorbing malfunction may be caused by the clogging of the mesh filter.

3. When the suction cup is pressed, make sure it stays within the stroke range.

If this product is used with a stroke exceeding the maximum stroke, the cup may be broken or may reach the end of its service life earlier.

4. Suction cups are consumable. Please replace them when cracks or deformation is confirmed during periodic maintenance.

5. The workpiece size must be equal to or greater than the minimum curvature radius for adsorption.

If the workpiece size is smaller than the minimum curvature radius for adsorption, an adsorbing malfunction may occur.

6. As the adapter and cup are adhered to each other, they cannot be disassembled.

7. When adsorbing a plane, the cup skirt may be entrained depending on the workpiece with rough friction surface. Before using this product, sufficiently verify the adsorbing condition.

Safety Instructions

These safety instructions are intended to prevent hazardous situations and/or equipment damage. These instructions indicate the level of potential hazard with the labels of “**Caution**,” “**Warning**” or “**Danger**.” They are all important notes for safety and must be followed in addition to International Standards (ISO/IEC)*1), and other safety regulations.

 **Danger :** **Danger** indicates a hazard with a high level of risk which, if not avoided, will result in death or serious injury.

 **Warning:** **Warning** indicates a hazard with a medium level of risk which, if not avoided, could result in death or serious injury.

 **Caution:** **Caution** indicates a hazard with a low level of risk which, if not avoided, could result in minor or moderate injury.

*1) ISO 4414: Pneumatic fluid power - General rules and safety requirements for systems and their components
ISO 4413: Hydraulic fluid power - General rules and safety requirements for systems and their components
IEC 60204-1: Safety of machinery - Electrical equipment of machines - Part 1: General requirements
ISO 10218-1: Robots and robotic devices - Safety requirements for industrial robots - Part 1: Robots etc.

Warning

1. The compatibility of the product is the responsibility of the person who designs the equipment or decides its specifications.

Since the product specified here is used under various operating conditions, its compatibility with specific equipment must be decided by the person who designs the equipment or decides its specifications based on necessary analysis and test results. The expected performance and safety assurance of the equipment will be the responsibility of the person who has determined its compatibility with the product. This person should also continuously review all specifications of the product referring to its latest catalog information, with a view to giving due consideration to any possibility of equipment failure when configuring the equipment.

2. Only personnel with appropriate training should operate machinery and equipment.

The product specified here may become unsafe if handled incorrectly. The assembly, operation and maintenance of machines or equipment including our products must be performed by an operator who is appropriately trained and experienced.

3. Do not service or attempt to remove product and machinery/equipment until safety is confirmed.

1. The inspection and maintenance of machinery/equipment should only be performed after measures to prevent falling or runaway of the driven objects have been confirmed.
2. When the product is to be removed, confirm that the safety measures as mentioned above are implemented and the power from any appropriate source is cut, and read and understand the specific product precautions of all relevant products carefully.
3. Before machinery/equipment is restarted, take measures to prevent unexpected operation and malfunction.

4. SMC products cannot be used beyond their specifications. They are not developed, designed, and manufactured to be used under the following conditions or environments. Use under such conditions or environments is not allowed.

1. Conditions and environments outside of the given specifications, or use outdoors or in a place exposed to direct sunlight.
2. Use for nuclear power, railways, aviation, space equipment, ships, vehicles, military application, equipment affecting human life, body, and property, combustion equipment, entertainment equipment, emergency shut-off circuits, press clutches, brake circuits, safety equipment, etc., and use for applications that do not conform to standard specifications such as catalogs and operation manuals.
3. Use for interlock circuits, except for use with double interlock such as installing a mechanical protection function in case of failure. Please periodically inspect the product to confirm that the product is operating properly.

Caution

SMC develops, designs, and manufactures products to be used for automatic control equipment, and provides them for peaceful use in manufacturing industries.

Use in non-manufacturing industries is not allowed.

Products SMC manufactures and sells cannot be used for the purpose of transactions or certification specified in the Measurement Act of each country. The new Measurement Act prohibits use of any unit other than SI units in Japan.

Limited warranty and Disclaimer/ Compliance Requirements

The product used is subject to the following “Limited warranty and Disclaimer” and “Compliance Requirements”.

Read and accept them before using the product.

Limited warranty and Disclaimer

1. The warranty period of the product is 1 year in service or 1.5 years after the product is delivered, whichever is first.*2)
Also, the product may have specified durability, running distance or replacement parts. Please consult your nearest sales branch.
2. For any failure or damage reported within the warranty period which is clearly our responsibility, a replacement product or necessary parts will be provided.
This limited warranty applies only to our product independently, and not to any other damage incurred due to the failure of the product.
3. Prior to using SMC products, please read and understand the warranty terms and disclaimers noted in the specified catalog for the particular products.

*2) **Suction cups (Vacuum pads) are excluded from this 1 year warranty.**

A suction cup (vacuum pad) is a consumable part, so it is warranted for a year after it is delivered.

Also, even within the warranty period, the wear of a product due to the use of the suction cup (vacuum pad) or failure due to the deterioration of rubber material are not allowed by the limited warranty.

Compliance Requirements

1. The use of SMC products with production equipment for the manufacture of weapons of mass destruction (WMD) or any other weapon is strictly prohibited.
2. The exports of SMC products or technology from one country to another are governed by the relevant security laws and regulations of the countries involved in the transaction. Prior to the shipment of a SMC product to another country, assure that all local rules governing that export are known and followed.

Revision History

Edition B * A bowl bellows shape (ø50, ø63, and ø80) has been added.
* The number of pages has been increased from 12 to 20.

Edition C * An oval flat shape (16 x 50, 30 x 90, 40 x 80, and 50 x 100) has been added.
* The number of pages has been increased from 20 to 28.

 **Safety Instructions** Be sure to read the “Handling Precautions for SMC Products” (M-E03-3) and “Operation Manual” before use.