

# Vacuum Unit

# Series 25A-ZK2

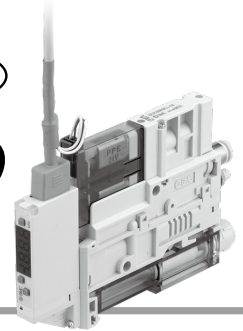

## How to Order Single Unit

Ejector System (with Valve)

25A-ZK2 **A** **12** **K** **5** **A** **L** - **08** -

Ejector System (without Valve)

25A-ZK2 **A** **12** **N** **0** **N** **N** - **08** -

① ② ③ ④ ⑤ ⑥ ⑦ ⑧

Remains blank when option is not selected.

### ① System/Body type

Symbol	System	Body type	Exhaust type
A	Ejector system	Single unit	Silencer exhaust
			Port exhaust <small>Note 1)</small>
B			Port exhaust <small>Note 1)</small>

Note 1) Port size of exhaust port:  $\phi 8$  (Metric)

### ③ Combination of supply valve and release valve Note 3)

Symbol	Supply valve	Release valve
<small>Note 5)</small> K	N.C.	N.C.
J	N.C.	None
R	Self-holding release valve linked <small>Note 4)</small>	N.C.
N	None	None

Note 3) Only non-locking type is available for the manual override for "K, J, R".  
 Note 4) Self-holding type maintains vacuum by instantaneous energization (20 ms or more). Stopping the vacuum turns on the release valve. (signal to stop vacuum not needed)  
 Note 5) When the digital pressure switch for vacuum with energy saving function is selected for ⑤, select "K" for ③ Combination of supply valve and release valve.

### ② Nominal nozzle size

Symbol	System	Nominal size
07	Ejector system <small>Note 2)</small>	$\phi 0.7$
10		$\phi 1.0$
12		$\phi 1.2$
15		$\phi 1.5$

Note 2) Standard supply pressure for nozzle size 07 to 12 is 0.35 MPa, 15 is 0.4 MPa

### ④ Rated voltage Note 6)

Symbol	Voltage
5	24 VDC
6	12 VDC
0	When ③ is "N"

Note 6) Rated voltage for the supply and release valve

### ⑤ Pressure sensor/Digital pressure switch for vacuum specifications

Symbol	Type	Pressure range [kPa]	Specifications
P	Pressure sensor	0 to -101	Analog output 1 to 5 V
T		-100 to 100	Analog output 1 to 5 V
A	Digital pressure switch for vacuum	0 to -101	NPN 2 outputs Unit selection function <small>Note 7)</small> SI unit only <small>Note 8)</small>
B			SI unit only <small>Note 8)</small>
C			SI unit only <small>Note 8)</small>
D		-100 to 100	NPN 2 outputs Unit selection function <small>Note 7)</small> SI unit only <small>Note 8)</small>
E			SI unit only <small>Note 8)</small>
F			SI unit only <small>Note 8)</small>
H	-100 to 100	NPN 2 outputs Unit selection function <small>Note 7)</small> SI unit only <small>Note 8)</small>	Digital pressure switch for vacuum with energy saving function
J			SI unit only <small>Note 8)</small>
K			SI unit only <small>Note 8)</small>
Q	Digital pressure switch for vacuum with energy saving function <small>Note 9)</small>	-100 to 100	NPN 1 output Unit selection function <small>Note 7)</small> SI unit only <small>Note 8)</small>
R			SI unit only <small>Note 8)</small>
S			PNP 1 output Unit selection function <small>Note 7)</small> SI unit only <small>Note 8)</small>
N	Without pressure sensor/ Digital pressure switch for vacuum		

Note 7) Unit selection function is not available in Japan due to new measurement law.  
 Note 8) Fixed unit: kPa  
 Note 9) When "K, Q, R or S" is selected, select "K" for ③ Combination of supply valve and release valve. Select "W" or "L3" for ⑥.

Manifold type is not available.

- PV: Air pressure supply port/Port for vacuum source (Vacuum pump)
- PS: Pilot pressure supply port ● PD: Individual release pressure supply port
- V: Vacuum port ● EXH: Exhaust port ● PE: Pilot pressure exhaust port

## 6 Supply valve/Release valve/Digital pressure switch for vacuum connector specifications

Symbol	3 For supply valve/release valve <small>Note 10)</small>		5 Lead wire with connector for pressure switch/ sensor <small>Note 13)</small>	
	Connector type	Lead wire with connector		
L		○ <small>Note 11)</small>	○ <small>Note 14)</small>	
L1		× <small>Note 12)</small>	○ <small>Note 14)</small>	
L2	L-type plug connector	○ <small>Note 11)</small>	× <small>Note 15)</small>	
L3		× <small>Note 12)</small>	× <small>Note 15)</small>	
W		With lead wire for switch with energy saving function		
Y	Non-valve (without supply/release valve)		○ <small>Note 14)</small>	
Y1	When "N" is selected for 3		×	
N	When "N" is selected for both 3 and 5 (without supply/release valve, without switch, pressure sensor)			

- Note 10) Solenoid valve with light/surge voltage suppressor  
 Note 11) Standard lead wire length for solenoid valve is 300 mm.  
 Note 12) For lead wire lengths other than standard, select "L1 or L3", and order the connector assembly desired. (Refer to the table on the right.)  
 Note 13) Standard lead wire length for pressure sensor is 3 m. Standard lead wire length with connector for vacuum pressure switch and the lead wire length for switch with energy saving function is 2 m.  
 Note 14) Select "L, L1, Y" when the pressure sensor (P, T) is selected for 5 Pressure sensor/Digital pressure switch for vacuum specifications. Since only grommet type is available for the pressure sensor, sensor without lead wire cannot be selected.  
 Note 15) Select when no vacuum pressure switch, pressure sensor, or vacuum pressure switch with connector without lead wire is used.

## 8 Optional specifications/Functions/Applications Note 17)

Symbol	Type	Function/Application	
Nil	Without option	—	
B	With one bracket for mounting a single unit (Mounting screw is attached.)	Use when a single unit is mounted to the floor in an upright position is requested. (The part number for ordering only a bracket is ZK2-BK1-A. Bolt nuts are included.)	
D	With individual release pressure supply (PD) port type <small>Note 18)</small>	Use when supply pressure for vacuum release which pressure is different from the ejector supply pressure is requested.	
J	Vacuum break flow adjustment needle Round lock nut type	Thicker than standard hexagon type. More suitable for hand tightening. Round lock nut improves operability when port exhaust type is used.	
K	Vacuum break flow adjustment needle Screwdriver operation type	Slotted type improves fine adjustment performance when port exhaust type is used.	
W	With exhaust interference prevention valve <small>Note 19), 20), 21)</small>	When ejectors are operated individually, exhausted air may flow backward from the V port of ejectors that are OFF. Exhaust interference prevention valve prevents back flow.	

Note) Refer to the **WEB catalog** or the Best Pneumatics No. 4 when mounting single unit to DIN rail.

## 7 Vacuum (V) port Note 16)

Symbol	Type	Port size	
06	Metric size	ø6 One-touch fitting	
08		ø8 One-touch fitting	

Note 16) Supply port size of single unit: ø6

## Connector assembly

ZK2 - LV W - A

Applicable valve type ●		Lead wire length ●	
W	Valve type K/R (With supply valve and release valve)	Nil	300 mm
		6	600 mm
S	Valve type J (Supply valve only)	10	1000 mm
		20	2000 mm
		30	3000 mm

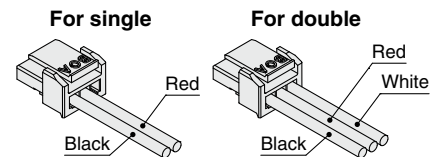

## Single Unit and Options Note 22)

		1	2	3	4	5	6	7	8			
		A	07 10 12 15	K J R N	5 6 0	P to N	L to N	06 08	B	D	J	K
ZK2	B								●	●	●	●

Note 22) When "J" or "N" is selected for 3 Combination of Supply Valve and Release Valve, "D, J or K" cannot be selected for 8 Optional Specifications/Functions/Applications. For options not in the table, please contact SMC.

- Note 17) When more than one option is selected, list the option symbols in an alphabetical order. Example) -BJ  
 Note 18) Use One-touch fittings or barb fittings with O.D. ø8 or less for piping. (Recommended fitting: KQ2S23-M3G)  
 Note 19) To prevent backflow of the exhaust air, not for holding vacuum. This option does not completely stop the backflow of the exhaust air. Select port exhaust type depending on purpose.  
 Note 20) When "J" is selected for 3 Combination of supply valve and release valve and "W" (exhaust interference prevention valve type) is selected for 8 Optional specifications/Functions/Applications, install a release valve or vacuum breaker.  
 Note 21) When "K", "Q", "R", or "S" is selected for 5 Pressure sensor/Digital pressure switch for vacuum specifications, the exhaust interference prevention valve is provided. So, it is not necessary to select "W".

# Series 25A-ZK2

## Replacement Parts/How to Order

### ■ Vacuum pressure switch assembly

25A - ZK2 - ZS **E** **A** **M** **G** - A

①
②
③
④

#### ① Rated pressure range and function

<b>E</b>	0 to -101 kPa	Vacuum pressure switch	Open collector 2 outputs
<b>F</b>	-100 to 100 kPa		
<b>V</b>	-100 to 100 kPa	Pressure switch with energy saving function	Open collector 1 output

#### ② Output specifications

<b>A</b>	NPN
<b>B</b>	PNP

#### ③ Unit specifications

<b>Nil</b>	Unit selection function <small>Note 1)</small>
<b>M</b>	SI unit only <small>Note 2)</small>

Note 1) Unit selection function is not available in Japan due to measurement law.

Note 2) Fixed unit: kPa

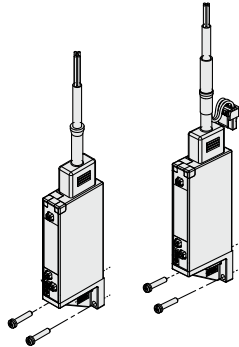

#### ④ Lead wire with connector

<b>Nil</b>	None	
<b>G</b>	With lead wire	When ① is E or F...For vacuum pressure switch, Lead wire with connector (Length 2 m)
		When ① is V...For switch with energy saving function, Lead wire with connector (Length 2 m)

### ■ Lead wire with connector for vacuum pressure switch

(When individual lead wire is necessary, order with the part number below.)

#### ● Lead wire with connector for vacuum pressure switch ZS - 39 - 5G

#### ● Lead wire with connector for switch with energy saving function

ZK2 - LW **A** 20 - A

#### ● Output specifications

<b>A</b>	NPN open collector
<b>B</b>	PNP open collector

### ■ Pressure sensor assembly

25A - ZK2 - PS **1** - A

#### Rated pressure range and specifications

<b>1</b>	0 to -101 kPa, Output: 1 to 5 V, Accuracy: ±2% F.S. or less
<b>3</b>	-100 to 100 kPa, Output: 1 to 5 V, Accuracy: ±2% F.S. or less

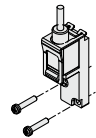

Auto Switches	Electric Actuators	Fluid Control Equipment	Detection Switches	Fittings/Flow Control Equipment	Air Filters/Pressure Control Equipment	Clean Air Filters	Air Preparation Equipment	Vacuum Equipment	Air Grippers	Rotary Actuators	Related Products	Air Cylinders	Directional Control Valves
---------------	--------------------	-------------------------	--------------------	---------------------------------	--	-------------------	---------------------------	------------------	--------------	------------------	------------------	---------------	----------------------------



[Option]  
Note) CE-compliant:  
For DC only.

# Space Saving Vacuum Ejector Series 25A-ZQ

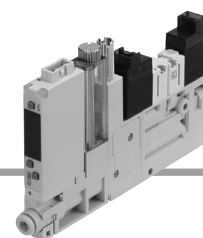

## How to Order

### Ejector Unit

**25A-ZQ1** 05 1U - K1   5 L   - EA   G   -     -  

• Series compatible with secondary batteries

#### ① Nozzle nominal size

05	ø0.5
07	ø0.7
10	ø1.0

#### ② Exhaust type

1U	With silencer for single unit
3M	With silencer for manifold

#### ③ Solenoid valve combination (Refer to Table (1).)

Symbol	Supply valve	Vacuum release valve
<b>K1</b>	Normally closed	Normally closed
<b>K2</b> <small>Note 1)</small>	Normally open	Normally closed
<b>J1</b>	Normally closed	None
<b>J2</b> <small>Note 1)</small>	Normally open	None
<b>Q1</b>	Latching positive common	Normally closed
<b>Q2</b>	Latching positive common	None
<b>N1</b>	Latching negative common	Normally closed
<b>N2</b>	Latching negative common	None

Note 1) In cases when "K2" or "J2" (supply valve normally open) is selected for the solenoid valve combination, when vacuum is stopped for long periods of time (10 minutes or more), do not continue to energize the supply valve, and shut off the air supply.

#### ④ Pilot valve (Refer to Table (1).)

Nil	Standard (DC: 1 W) <sup>Note 2)</sup>
Y	DC low wattage type (0.5 W) <sup>Note 2)</sup>

Note 2) Avoid energizing the solenoid valve for long periods of time. (Refer to Design and Selection on Specific Product Precautions.)

#### ⑤ Solenoid valve rated voltage (Refer to Table (1).)

		CE-compliant
<b>1</b> <small>Note 3)</small>	100 VAC (50/60 Hz)	—
<b>2</b> <small>Note 3)</small>	200 VAC (50/60 Hz)	—
<b>3</b> <small>Note 3)</small>	110 VAC (50/60 Hz)	—
<b>4</b> <small>Note 3)</small>	220 VAC (50/60 Hz)	—
<b>5</b>	24 VDC	●
<b>6</b>	12 VDC	●

Note 3) CE-compliant products are not available for "1", "2", "3" and "4".

**Table (1) Combination of Solenoid Valve, Pilot Valve and Power Supply Voltage**

Combination no.	Solenoid valve combination symbol	Pilot valve symbol	Applicable power supply voltage (V)					
			100 AC	200 AC	110 AC	220 AC	24 DC	12 DC
①	K1	Nil	—	—	—	—	●	●
②	K1	Y	—	—	—	—	●	●
③	K2	Nil	—	—	—	—	●	●
④	J1	Nil	●	●	●	●	●	●
⑤	J1	Y	—	—	—	—	●	●
⑥	J2	Nil	—	—	—	—	●	●
⑦	Q1	Nil	—	—	—	—	●	●
⑧	Q2	Nil	●	●	●	●	●	●
⑨	N1	Nil	—	—	—	—	●	●
⑩	N2	Nil	—	—	—	—	●	●

\* Combinations ① to ⑩ in the above table are the only possible options.

## ⑥ Electrical entry

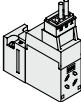
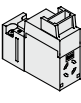
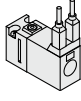
<b>L</b>	L-type plug connector, with 0.3 m lead wire, with light/surge voltage suppressor	
<b>LO</b>	L-type plug connector, without connector, with light/surge voltage suppressor	
<b>G</b>	Grommet, with 0.3 m lead wire (Latching/AC type: Not applicable)	

## ⑦ Manual override Note 4)

<b>Nil</b>	Non-locking push type Latching type: Push-locking type
<b>B</b>	Locking type (Q1/Q2/N1/N2: Not applicable)

Note 4) Latching type supply valve: Available in "Nil" only. In this case, the supply valve and release valve come with a push-locking type.

## ⑧ Vacuum pressure switch suction filter Note 5)

<b>EA</b>	0 to -101 kPa/NPN open collector 2 outputs, with suction filter
<b>EB</b>	0 to -101 kPa/PNP open collector 2 outputs, with suction filter
<b>EC</b>	0 to -101 kPa/NPN open collector 1 output + analog voltage, with suction filter
<b>EE</b>	0 to -101 kPa/PNP open collector 1 output + analog voltage, with suction filter
<b>FA</b>	100 to -100 kPa/NPN open collector 2 outputs, with suction filter
<b>FB</b>	100 to -100 kPa/PNP open collector 2 outputs, with suction filter
<b>FC</b>	100 to -100 kPa/NPN open collector 1 output + analog voltage, with suction filter
<b>FE</b>	100 to -100 kPa/PNP open collector 1 output + analog voltage, with suction filter
<b>F</b>	Suction filter only

Note 5) The filter included in this product is of a simple type, and will become clogged quickly in environments with high quantities of dust or particulates. Please make additional use of an air suction filter of the ZFA, ZFB or ZFC series.

### **⚠ Warning**

The filter case of this suction filter is made of nylon. Contact with alcohol or similar chemicals may cause it to be damaged. Also, do not use the filter when these chemicals are present in the atmosphere.

## ⑪ Check valve Note 8)

<b>Nil</b>	None
<b>K</b>	With check valve

Note 8) The check valve has a function to prevent the exhaust air from the silencer overflowing to the vacuum port side when a manifold is used. However, depending on usage conditions, it does not always suppress air overflow to the desired extent. During usage, please inspect thoroughly with actual machine. Also, in order to completely prevent the overflow of exhaust air, leave plenty of space between the check valve unit and adjacent ejector to avoid interference from the ejector's exhaust unit.

### **⚠ Warning**

- ① Cannot be used for vacuum retention.
- ② Use a release valve. (Without a release valve, a workpiece may not be released.)

## ⑫ Fitting (V port)

<b>Symbol</b>	Applicable tubing O.D.
<b>0</b>	Without fitting (M5 x 0.8)

## ⑬ Fitting (P port)

<b>Symbol</b>	Applicable tubing O.D.	Object spec.
<b>Nil</b>	Without port	Manifold
<b>0</b>	Without fitting (M5 x 0.8)	Single unit

## ⑨ Vacuum pressure switch unit specifications

<b>Nil</b>	With unit switching function <small>Note 6)</small>
<b>M</b>	Fixed SI unit <small>Note 7)</small>
<b>P</b>	With unit switching function <small>Note 6)</small> (Initial value psi)

Note 6) Under the New Measurement Law, sales of switches with the unit switching function are not allowed for use in Japan.

Note 7) Fixed unit: kPa

## ⑩ Vacuum pressure switch lead wire specifications

<b>Nil</b>	Without connector
<b>G</b>	Lead wire with connector (Lead wire length 2 m) With connector cover

## ⑭ CE-compliant

<b>Nil</b>	—
<b>Q</b>	CE-compliant

Note) CE-compliant: For DC only.

\* Specifications and dimensions for the 25A-series are the same as standard products.

## How to Order

**Manifold**

**25A – ZZQ1 07 – B S C**

**Number of stations** Note)

01	1 station
02	2 stations
⋮	⋮
08	8 stations

Note) Number of stations varies according to nozzle nominal size during simultaneous operation.

**Maximum Number of Stations in Simultaneous Operation**

Nozzle nominal size	Maximum number of stations in simultaneous operation
ø0.5	8 stations
ø0.7	6 stations
ø1.0	4 stations

**Air pressure supply (P) port position**

<b>B</b>	Both sides
----------	------------

**Exhaust**

<b>S</b>	With silencers (Both sides)
----------	-----------------------------

**Vacuum release pressure supply port (PD port)**

<b>B</b>	None (Release pressure is supplied from the P port.)
<b>C</b>	Provided (Air can be alternatively supplied from the P port.)

\* Specifications and dimensions for the 25A-series are the same as standard products.

## How to Order

### Solenoid valve

**Actuation**

1	Normally closed
2	Normally open

**25A-ZQ1-VQ1 1 0** **5 L**

**25A-ZQ1-VQ1 2 0** **5 L**

**Pilot valve**

Nil	Standard (DC: 1 W)
Y	DC low wattage type (0.5 W) *AC type: Not applicable
L	Latching positive common
N	Latching negative common

**Solenoid valve rated voltage**

1	100 VAC (50/60 Hz)
2	200 VAC (50/60 Hz)
3	110 VAC (50/60 Hz)
4	220 VAC (50/60 Hz)
5	24 VDC
6	12 VDC

**Actuation**

Nil	Standard (1 W)
-----	----------------

**Solenoid valve rated voltage**

5	24 VDC
6	12 VDC

**Manual override** <sup>Note)</sup>

Nil	Non-locking push type
B	Latching type: Push-locking type
	Locking type

Note) Latching type: Available in "Nil" only

**Electrical entry** <sup>Note)</sup>

L	L-type plug connector, with 0.3 m lead wire	
LO	L-type plug connector, without connector	
G	Grommet, with 0.3 m lead wire (Latching/AC type: Not applicable)	

Note) Mounting screws are attached.

### Vacuum pressure switch

**25A-ZQ1-ZS** **A**

**Vacuum pressure switch specifications**

EA	0 to -101 kPa/NPN open collector 2 outputs, with suction filter
EB	0 to -101 kPa/PNP open collector 2 outputs, with suction filter
EC	0 to -101 kPa/NPN open collector 1 output + analog voltage, with suction filter
EE	0 to -101 kPa/PNP open collector 1 output + analog voltage, with suction filter
FA	100 to -100 kPa/NPN open collector 2 outputs, with suction filter
FB	100 to -100 kPa/PNP open collector 2 outputs, with suction filter
FC	100 to -100 kPa/NPN open collector 1 output + analog voltage, with suction filter
FE	100 to -100 kPa/PNP open collector 1 output + analog voltage, with suction filter

**Vacuum pressure switch unit specifications**

Nil	With unit switching function <sup>Note 1)</sup>
M	Fixed SI unit <sup>Note 2)</sup>
P	With unit switching function <sup>Note 1)</sup> (Initial value psi)

Note 1) Under the New Measurement Law, sales of switches with the unit switching function are not allowed for use in Japan.  
Note 2) Fixed unit: kPa

**Vacuum pressure switch lead wire specifications**

Nil	Without connector
G	Lead wire with connector (lead wire length 2 m) With connector cover

**Fitting (V port)**

Symbol	Applicable tubing O.D.
0	Without fitting (M5 x 0.8)

**Check valve** <sup>Note 3)</sup>

Nil	None
K	With check valve

Note 3) The check valve has a function to prevent the exhaust air from the silencer overflowing to the vacuum port side when a manifold is used, but it is incapable of completely preventing overflow. During usage, please inspect thoroughly with actual machine. Also, in order to completely prevent the overflow of exhaust air, leave plenty of space between the check valve unit and adjacent ejector to avoid interference from the ejector's exhaust unit.

**Warning**

- Cannot be used for vacuum retention.
- Use a vacuum release valve. (Without a vacuum release valve, the workpiece may not be released.)

Lead wire with connector part no.	Note
ZS-39-5G	Lead wire length 2 m (With connector cover)

\* Specifications and dimensions for the 25A-series are the same as standard products.





[Option]  
Note) CE-compliant:  
For DC only.

# Space Saving Vacuum Pump System

## Series 25A-ZQ

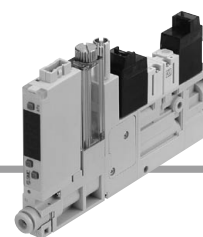

### How to Order

#### Vacuum pump unit

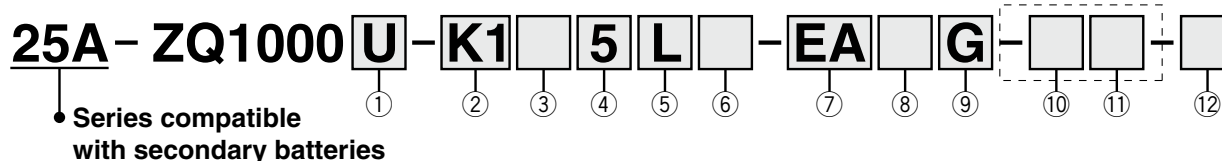

#### ① Body type

<b>U</b>	For single unit
<b>M</b>	For manifold

#### ② Solenoid valve combination (Refer to Table (1).)

Symbol	Supply valve	Vacuum release valve
<b>K1</b>	Normally closed	Normally closed
<b>K2</b> <small>Note 1)</small>	Normally open	Normally closed
<b>J1</b>	Normally closed	None
<b>J2</b> <small>Note 1)</small>	Normally open	None
<b>Q1</b>	Latching positive common	Normally closed
<b>Q2</b>	Latching positive common	None
<b>N1</b>	Latching negative common	Normally closed
<b>N2</b>	Latching negative common	None

⚠ The air in the adsorption section of this product is not released to the atmosphere at the vacuum suspension state.  
As for "K1", "K2", "Q1" and "N1", use the vacuum release valve when a workpiece is detached.  
Concerning "J1", "J2", "Q2" and "N2", devise the circuit for the vacuum release additionally when a workpiece is detached.

Note 1) In cases when "K2" or "J2" (supply valve normally open) is selected for the solenoid valve combination, when vacuum is stopped for long periods of time (10 minutes or more), do not continue to energize the supply valve, and shut off the air supply.

#### ③ Pilot valve (Refer to Table (1).)

<b>Nil</b>	Standard (DC: 1 W) <small>Note 2)</small>
<b>Y</b>	DC low wattage type (0.5 W) <small>Note 2)</small>

Note 2) Avoid energizing the solenoid valve for long periods of time. (Refer to Specific Product Precautions; Caution on Design and Selection.)

#### ④ Solenoid valve rated voltage (Refer to Table (1).)

		CE-compliant
<b>1</b> <small>Note 3)</small>	100 VAC (50/60 Hz)	—
<b>2</b> <small>Note 3)</small>	200 VAC (50/60 Hz)	—
<b>3</b> <small>Note 3)</small>	110 VAC (50/60 Hz)	—
<b>4</b> <small>Note 3)</small>	220 VAC (50/60 Hz)	—
<b>5</b>	24 VDC	●
<b>6</b>	12 VDC	●



Note 3) CE-compliant products are not available for "1", "2", "3" and "4".

**Table (1) Combination of Solenoid Valve, Pilot Valve and Rated Voltage**

Combination no.	Solenoid valve combination symbol	Pilot valve symbol	Applicable power supply voltage (V)					
			100 AC	200 AC	110 AC	220 AC	24 DC	12 DC
①	<b>K1</b>	<b>Nil</b>	—	—	—	—	●	●
②	<b>K1</b>	<b>Y</b>	—	—	—	—	●	●
③	<b>K2</b>	<b>Nil</b>	—	—	—	—	●	●
④	<b>J1</b>	<b>Nil</b>	●	●	●	●	●	●
⑤	<b>J1</b>	<b>Y</b>	—	—	—	—	●	●
⑥	<b>J2</b>	<b>Nil</b>	—	—	—	—	●	●
⑦	<b>Q1</b>	<b>Nil</b>	—	—	—	—	●	●
⑧	<b>Q2</b>	<b>Nil</b>	●	●	●	●	●	●
⑨	<b>N1</b>	<b>Nil</b>	—	—	—	—	●	●
⑩	<b>N2</b>	<b>Nil</b>	—	—	—	—	●	●

\* Combinations ① to ⑩ in the above table are the only possible options.

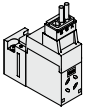
## ⑤ Electrical entry

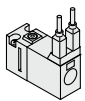
<b>L</b>	L-type plug connector, with 0.3 m lead wire, with light/surge voltage suppressor	
<b>LO</b>	L-type plug connector, without connector, with light/surge voltage suppressor	
<b>G</b>	Grommet, with 0.3 m lead wire (Latching/AC type: Not applicable)	

## ⑥ Manual override <sup>Note 4)</sup>

<b>Nil</b>	Non-locking push type Latching type: Push-locking type
<b>B</b>	Locking type (Q1/Q2/N1/N2: Not applicable)

Note 4) Latching type supply valve: Available in "Nil" only.  
In this case, the supply valve and release valve come with a push-locking type.

## ⑦ Vacuum pressure switch suction filter <sup>Note 5)</sup>

<b>EA</b>	0 to -101 kPa/NPN open collector 2 outputs, with suction filter
<b>EB</b>	0 to -101 kPa/PNP open collector 2 outputs, with suction filter
<b>EC</b>	0 to -101 kPa/NPN open collector 1 output + analog voltage, with suction filter
<b>EE</b>	0 to -101 kPa/PNP open collector 1 output + analog voltage, with suction filter
<b>FA</b>	100 to -100 kPa/NPN open collector 2 outputs, with suction filter
<b>FB</b>	100 to -100 kPa/PNP open collector 2 outputs, with suction filter
<b>FC</b>	100 to -100 kPa/NPN open collector 1 output + analog voltage, with suction filter
<b>FE</b>	100 to -100 kPa/PNP open collector 1 output + analog voltage, with suction filter
<b>F</b>	Suction filter only

Note 5) The filter included in this product is of a simple type, and will become clogged quickly in environments with high quantities of dust or particulates. Please make additional use of an air suction filter of the ZFA, ZFB or ZFC series.

### ⚠ Warning

The filter case of this suction filter is made of nylon. Contact with alcohol or similar chemicals may cause it to be damaged. Also, do not use the filter when these chemicals are present in the atmosphere.

## ⑩ Fitting (V port) <sup>Note 8)</sup>

Symbol	Applicable tubing O.D.
<b>0</b>	Without fitting (M5 x 0.8)

## ⑪ Fitting (PS / PV port) <sup>Note 8)</sup>

Symbol	Applicable tubing O.D.	Part no.	Object spec.
<b>Nil</b>	Without port	—	Manifold
<b>0</b>	Without fitting (M5 x 0.8)	—	Single unit

## ⑫ CE-compliant

<b>Nil</b>	—
<b>Q</b>	CE-compliant

Note) CE-compliant: For DC only.

Note 8) For filter only (Without vacuum pressure switch)  
When neither V port fitting nor PS/PV port fitting are needed, enter nothing or -00 in the dotted line "How to Order".

## ⑧ Vacuum pressure switch unit specifications

<b>Nil</b>	With unit switching function <sup>Note 6)</sup>
<b>M</b>	Fixed SI unit <sup>Note 7)</sup>
<b>P</b>	With unit switching function <sup>Note 6)</sup> (Initial value psi)

Note 6) Under the New Measurement Law, sales of switches with the unit switching function are not allowed for use in Japan.

Note 7) Fixed unit: kPa

## ⑨ Vacuum pressure switch lead wire specifications

<b>Nil</b>	Without connector
<b>G</b>	Lead wire with connector (Lead wire length 2 m) With connector cover

\* Specifications and dimensions for the 25A-series are the same as standard products.

Directional Control Valves  
 Air Cylinders  
 Related Products  
 Rotary Actuators  
 Air Grippers  
 Vacuum Equipment  
 Air Preparation Equipment  
 Clean Air Filters  
 Air Filters/Pressure Control Equipment  
 Fittings/Flow Control Equipment  
 Detection Switches  
 Fluid Control Equipment  
 Electric Actuators  
 Auto Switches

## How to Order

**Manifold** 25A-ZZQ1 **08** - **0** **0**

Number of stations ●

01	1 station
02	2 stations
⋮	⋮
08	8 stations

Vacuum pressure supply port (PV port)  
Port location  
(Refer to Table (1).) ●

L	Left side
R	Right side

**Table (1) Air Pressure Supply Port Location on the Manifold**

PD port	Manifold Port location	Left			Right		
		PS	PV	PD	PS	PV	PD
<b>B</b>	L (Left side)	—	●	—	● <sup>Note)</sup>	—	—
	R (Right side)	● <sup>Note)</sup>	—	—	—	●	—
<b>C</b>	L (Left side)	—	●	●	●	—	●
	R (Right side)	●	—	●	—	●	●

Note) The position of each port is shown as right and left sides viewed from the front side of the vacuum port.

Release pressure is commonly supplied from the PS port.

\* PS: Pilot pressure supply port, PV: Vacuum pressure supply port, PD: Release pressure supply port

Release pressure supply port (PD port) ●

<b>B</b>	None (Release pressure is supplied from the PS port.)
<b>C</b>	Provided (Air can be alternatively supplied from the PS port.)

\* Specifications and dimensions for the 25A-series are the same as standard products.

## How to Order

### Solenoid valve

**Actuation**

1	Normally closed
2	Normally open

**Pilot valve**

Nil	Standard (DC: 1 W)
Y	DC low wattage type (0.5 W) *AC type: Not applicable
L	Latching positive common
N	Latching negative common

**Solenoid valve rated voltage**

1	100 VAC (50/60 Hz)
2	200 VAC (50/60 Hz)
3	110 VAC (50/60 Hz)
4	220 VAC (50/60 Hz)
5	24 VDC
6	12 VDC

**Manual override** Note)

Nil	Non-locking push type
B	Latching type: Push-locking type
	Locking type

Note) Latching type: Available in "Nil" only

**Electrical entry** Note)

L	L-type plug connector, with 0.3 m lead wire	
LO	L-type plug connector, without connector	
G	Grommet, with 0.3 m lead wire (Latching/AC type: Not applicable)	

Note) Mounting screws are attached.

**Ordering Examples:**

25A-ZQ1-VQ1 1 0 [ ] - 5 L [ ]

25A-ZQ1-VQ1 2 0 [ ] - 5 L [ ]

**Solenoid valve rated voltage**

5	24 VDC
6	12 VDC

### Vacuum pressure switch

**25A-ZQ1-ZS [ ] [ ] [ ] [ ] - [ ] - A**

**Vacuum pressure switch specifications**

EA	0 to -101 kPa/NPN open collector 2 outputs, with suction filter
EB	0 to -101 kPa/PNP open collector 2 outputs, with suction filter
EC	0 to -101 kPa/NPN open collector 1 output + analog voltage, with suction filter
EE	0 to -101 kPa/PNP open collector 1 output + analog voltage, with suction filter
FA	100 to -100 kPa/NPN open collector 2 outputs, with suction filter
FB	100 to -100 kPa/PNP open collector 2 outputs, with suction filter
FC	100 to -100 kPa/NPN open collector 1 output + analog voltage, with suction filter
FE	100 to -100 kPa/PNP open collector 1 output + analog voltage, with suction filter

**Vacuum pressure switch unit specifications**

Nil	With unit switching function <small>Note 1)</small>
M	Fixed SI unit <small>Note 2)</small>
P	With unit switching function <small>Note 1)</small> (Initial value psi)

Note 1) Under the New Measurement Law, sales of switches with the unit switching function are not allowed for use in Japan.

Note 2) Fixed unit: kPa

**Vacuum pressure switch lead wire specifications**

Nil	Without connector
G	Lead wire with connector (Lead wire length 2 m) With connector cover

**Fitting (V port)**

Symbol	Applicable tubing O.D.
0	Without fitting (M5 x 0.8)

**Check valve** Note 3)

Nil	None
K	With check valve

Note 3) The check valve has a function to prevent the exhaust air from the silencer overflowing to the vacuum port side when a manifold is used, but it is incapable of completely preventing overflow. During usage, please inspect thoroughly with actual machine. Also, in order to completely prevent the overflow of exhaust air, leave plenty of space between the check valve unit and adjacent ejector to avoid interference from the ejector's exhaust unit.

**Warning**

- Cannot be used for vacuum retention.
- Use a vacuum release valve. (Without a vacuum release valve, the workpiece may not be released.)

Lead wire with connector part no.	Note
ZS-39-5G	Lead wire length 2 m (With connector cover)

\* Specifications and dimensions for the 25A-series are the same as standard products.