

! Contact our sales office for delivery dates and prices as this is a special model.

Specialized Product **P.G.** Point to Group information

Rotary Clamp Cylinder Rotation Stroke Zero-Type MKB40-X3322

Features

- The rotation stroke has been eliminated and the height has been reduced by 15 mm.
- Can be installed in locations with height restrictions
- The rotation direction (left or right) can be selected.

When unclamped (Compared based on the clamp position)

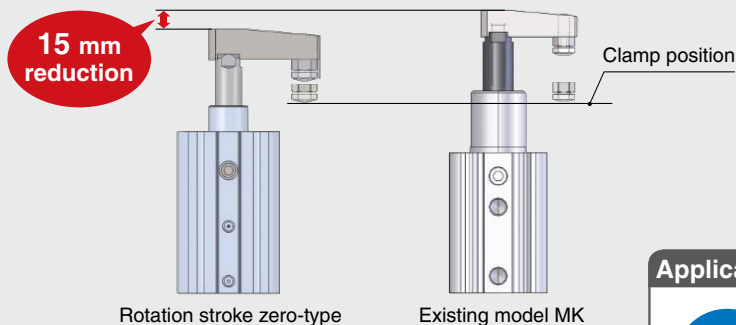

• Operation

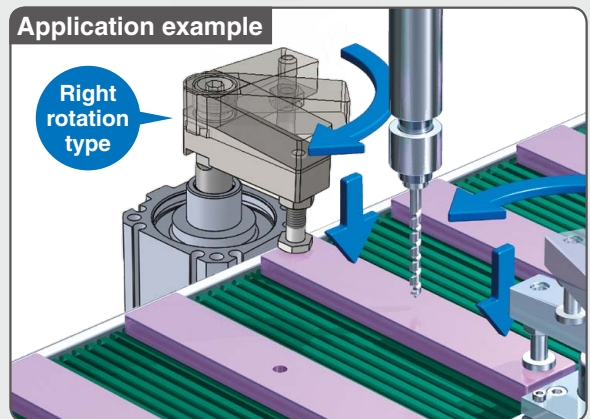
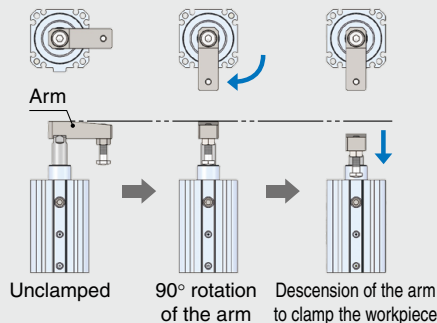

Allowable Bending Moment/Moment of Inertia

Allowable bending moment

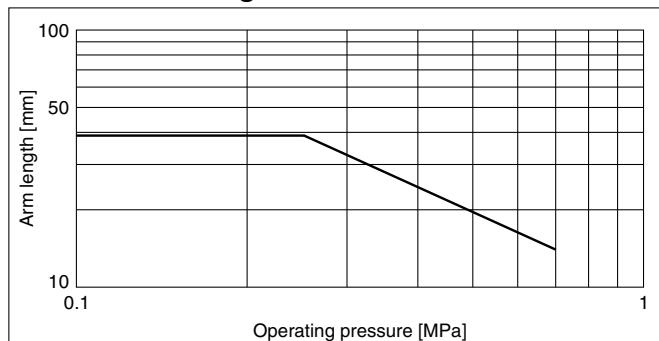

* When the arm length is 35 mm, the pressure should be 0.28 MPa or less.

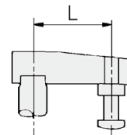

Moment of inertia

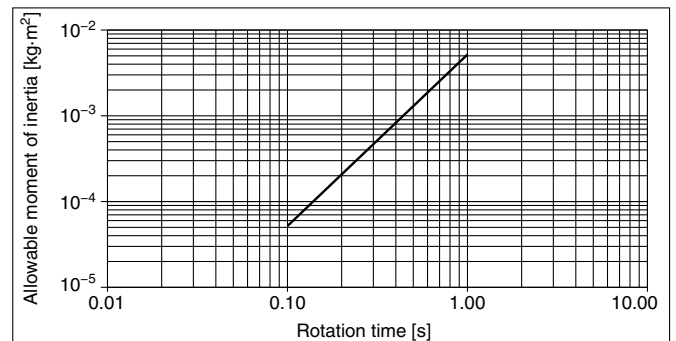

* When the arm's moment of inertia is 5.2×10^{-5} kg·m², set the rotation time required for a 90° rotation to 0.1 s or more.



Caution

To ensure the safest possible operation of this product, please be sure to thoroughly read the "Safety Instructions" in our "Best Pneumatics" catalog before use.

SMC Corporation 4-14-1, SOTO-KANDA, CHIYODA-KU, TOKYO 101-0021, JAPAN URL: <https://www.smcworld.com>

©2021 SMC Corporation All Rights Reserved



SP202X-005E
P: ZS