

! Contact our sales office for delivery dates and prices as this is a special model.

Specialized Product

Point to Group
P.G. information

Coolant-resistant Air Gripper

MHZJ2-32D-X6544

Features

- Increased resistance to splashing coolant
- Finger portion with collar protected by dust cover prevents contamination.
- Dust cover and plate connection prevent contamination.

Specifications

Model	MHZJ2-32D-X6544	
Gripping force (at 0.5 MPa)	O.D.	158 N
	I.D.	193 N
Finger stroke	22 mm	
Bore size	ø32	
Dust cover material	<ul style="list-style-type: none"> · Chloroprene rubber · Fluororubber · Silicone rubber 	
Weight	830 g	

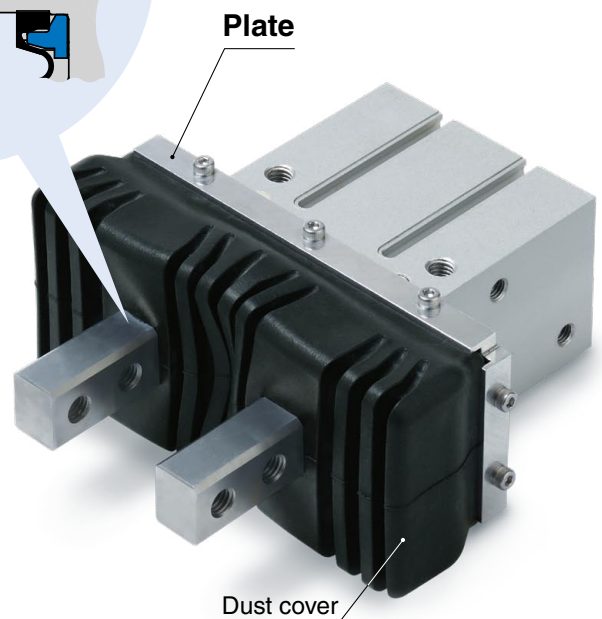
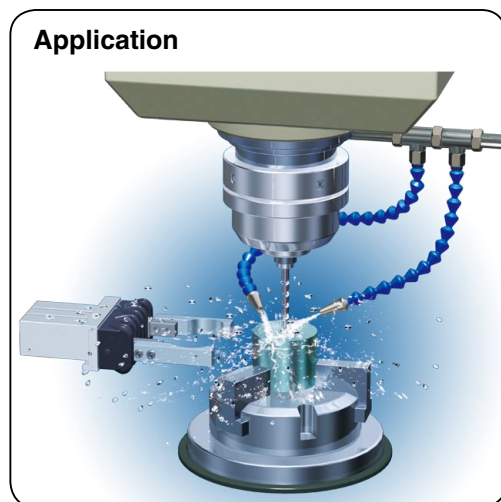
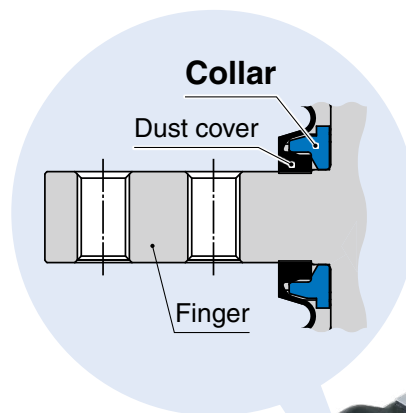

How to Order

MHZJ2-32D **F** - **M9BW** **□** - **X6544**

Dust cover option

Nil	Chloroprene rubber (CR)
F	Fluororubber (FKM)
S	Silicone rubber (SI)

• Coolant-resistant air gripper

• Number of auto switches
(Same as standard type)

• Auto switch
(Same as standard type)



Caution

To ensure the safest possible operation of this product, please be sure to thoroughly read the "Safety Instructions" in our "Best Pneumatics" catalog before use.

SMC Corporation 4-14-1, SOTO-KANDA, CHIYODA-KU, TOKYO 101-0021, JAPAN URL: <http://www.smcworld.com>

©2017 SMC Corporation All Rights Reserved



SP163X-013E
P: VU

Dimensions

MHZJ2-32D-X6544

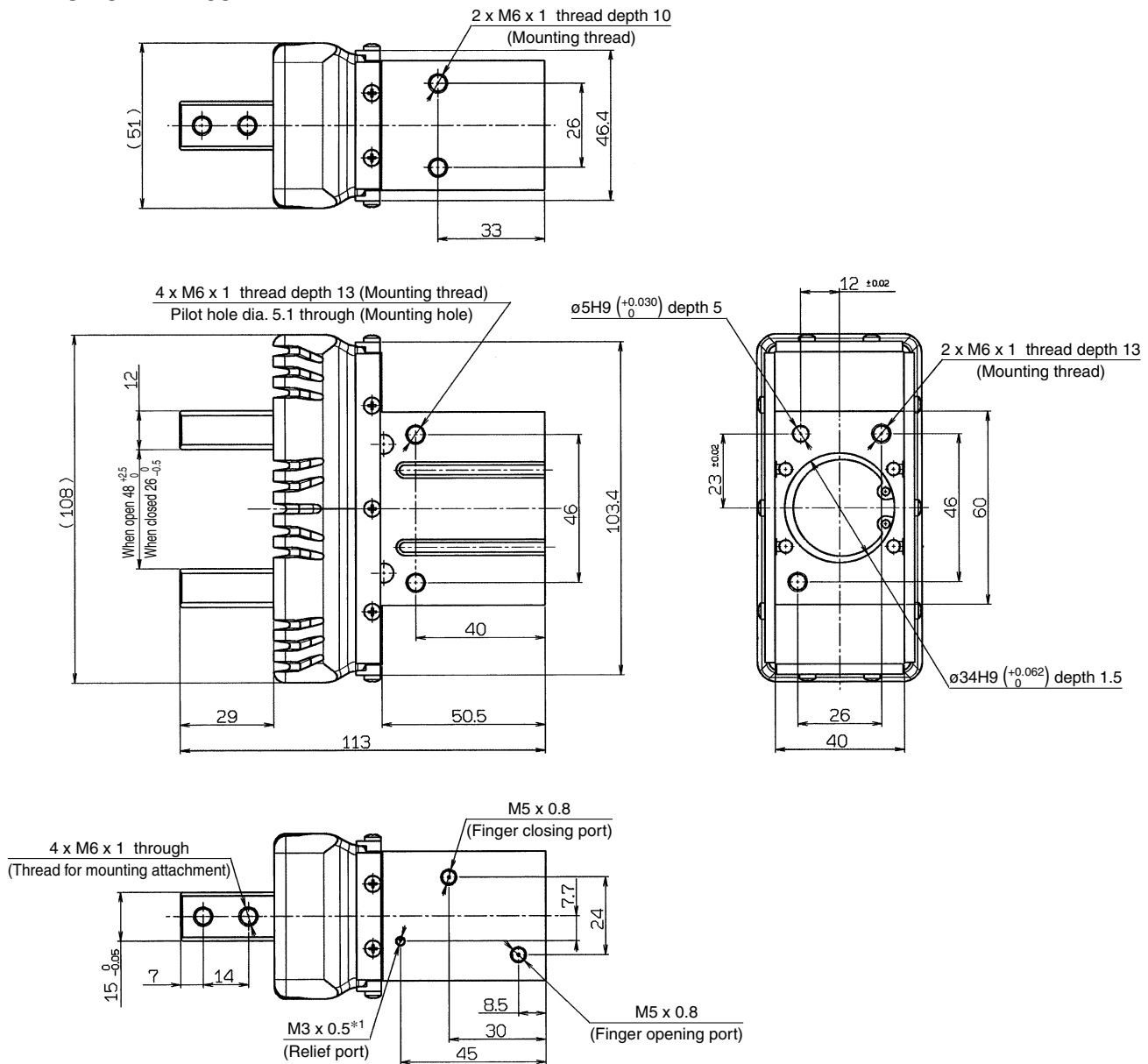

*1 The dust cover features an internal sealed construction which prevents internal pressure fluctuations. In addition, there is a relief port which allows for the release of the small amounts of air leaked from the air gripper.

Be sure to attach a fitting to the relief port to prevent foreign matter, liquid, etc., from entering the product. (The fitting should be prepared by the customer.)