



No. LEC-OM03907
(No. JXC※-OMU0029)

Operation Manual

PRODUCT NAME

***Programless controller
Step motor (servo 24 VDC)***

MODEL/ Series

LECP1 Series



SMC Corporation

Contents

1. Safety Instructions	4
2. Outlines of Product	6
2.1 Features	6
2.2 How to Order	7
2.3 Structure of the product	8
2.4 Procedure (How to start the actuator).....	9
(1) Checking the contents of the package	9
(2) Mounting the Controller	9
(3) Controller Wiring / Connection	9
(4) Power supply ON, and the Alarm check.....	10
(5) Data (Operation pattern) setting.....	10
(6) Test run.....	10
3. Specifications.....	11
3.1 Basic specifications	11
3.2 Details of the controller	12
3.3 Outer dimensions	13
(2) DIN rail mounting.....	13
(LECP1□□D-□)	13
(1) Mounting screw	13
(LECP1□□-□)	13
3.4 Mounting	14
(1) Mounting.....	14
(2) Connection to ground	14
(3) Location for mounting	15
4. External connection	16
4. 1 CN1: Power supply connector	16
4. 2 CN2: Motor power connector, CN3: Encoder connector	16
4. 3 CN4: Parallel I/O connector	16
5. CN1: Power supply cable.....	17
5. 1 Power supply cable specification	17
5. 2 Wiring of power supply cable	17
(1) Wiring of power supply	17
(2) Wiring of forced unlocking switch.....	18
(3) Stop the power supply for the motor	18
6. CN4: Parallel I/O cable	20
6.1 Parallel input / output.....	20
6.2 Parallel input / output circuit (NPN, PNP).....	20

(1) Parallel I/O input circuit (NPN, PNP common)	20
(2) Parallel I/O output circuit.....	20
6.3 Parallel input / output signal.....	21
6.4 Parallel I/O connector wiring (Example).....	23
7. Setting method	24
7.1 Setting procedure	25
7.2 Setting parameters	32
7.3 Controller modes	35
(A) Before return to origin.....	36
(B) Auto mode after return to origin	37
(C) Manual mode after return to origin.....	38
7.4 Test function	39
8. Operations	40
8.1 Return to origin.....	40
8.2 Positioning.....	41
8.3 Pushing operation.....	41
(1) Successful pushing operation	41
(2) Unsuccessful pushing operation (Idling)	42
(3) Movement of workpiece after the completion of the pushing process	42
8.4 Jog / inching operation	43
8.5 Servo ON	44
8.6 Response time for the controller input signal	44
8.7 LED display in auto mode.....	45
9. Operation (Example).....	46
9.1 Positioning / Return to origin.....	46
9.2 Pushing operation.....	47
9.3 Stoppage during operation.....	48
9.4 Alarm generation and reset.....	49
10. Initial setting value per actuator	50
10.1 Initial setting value of LEF series	50
10.2 Initial setting value of LEH series.....	53
10.3 Initial setting value of LES series	56
10.4 Initial setting value of LEY and LEYG series.....	57
10.5 Initial setting value of LER series.....	59
10.6 Initial setting value of LEP series	60
10.7 Initial setting value of LEL series.....	61
10.8 Initial setting value of LEM series.....	62

11. Options	63
11.1 Actuator cable [5 m or less].....	63
11.2 Actuator cable [8 to 20m]	63
11.3 Actuator cable (for sensor / lock) [5 m or less].....	64
11.4 Actuator cable (for sensor / lock) [8 to 20 m]	64
12. Alarm detection	65
12.1 Alarm group output	65
12.2 Alarms and countermeasures	66
13. Wiring of cables/Common precautions.....	69
14. Electric actuators/ Common precautions.....	70
14.1 Design and selection	70
14.2 Mounting	71
14.3 Handling	71
14.4 Operating environment	73
14.5 Maintenance.....	74
14.6 Precautions for actuator with lock	74
15. Controller and its peripheral devices / Specific product precautions.....	75
15.1 Design and selection	75
15.2 Handling	75
15.3 Installation	76
15.4 Wiring of cables/Common precautions	77
15.5 Power supply	77
15.6 Grounding.....	77
15.7 Maintenance.....	78
16. Troubleshooting	79
16.1 Operation troubles	79
16.2 Position / Speed troubles	81



LECP1 Series / Controller

1. Safety Instructions

These safety instructions are intended to prevent hazardous situations and/or equipment damage. These instructions indicate the level of potential hazard with the labels of “Caution,” “Warning” or “Danger.”

They are all important notes for safety and must be followed in addition to International Standards (ISO/IEC)*1), and other safety regulations.

*1) ISO 4414: Pneumatic fluid power -- General rules relating to systems.

ISO 4413: Hydraulic fluid power -- General rules relating to systems.

IEC 60204-1: Safety of machinery -- Electrical equipment of machines .(Part 1: General requirements)

ISO 10218: Manipulating industrial robots -Safety.

etc.



Caution

Caution indicates a hazard with a low level of risk which, if not avoided, could result in minor or moderate injury.



Warning

Warning indicates a hazard with a medium level of risk which, if not avoided, could result in death or serious injury.



Danger

Danger indicates a hazard with a high level of risk which, if not avoided, will result in death or serious injury.

Warning

1. The compatibility of the product is the responsibility of the person who designs the equipment or decides its specifications.

Since the product specified here is used under various operating conditions, its compatibility with specific equipment must be decided by the person who designs the equipment or decides its specifications based on necessary analysis and test results.

The expected performance and safety assurance of the equipment will be the responsibility of the person who has determined its compatibility with the product.

This person should also continuously review all specifications of the product referring to its latest catalog information, with a view to giving due consideration to any possibility of equipment failure when configuring the equipment.

2. Only personnel with appropriate training should operate machinery and equipment.

The product specified here may become unsafe if handled incorrectly.

The assembly, operation and maintenance of machines or equipment including our products must be performed by an operator who is appropriately trained and experienced.

3. Do not service or attempt to remove product and machinery/equipment until safety is confirmed.

1. The inspection and maintenance of machinery/equipment should only be performed after measures to prevent falling or runaway of the driven objects have been confirmed.

2. When the product is to be removed, confirm that the safety measures as mentioned above are implemented and the power from any appropriate source is cut, and read and understand the specific product precautions of all relevant products carefully.

3. Before machinery/equipment is restarted, take measures to prevent unexpected operation and malfunction.

4. Contact SMC beforehand and take special consideration of safety measures if the product is to be used in any of the following conditions.

1. Conditions and environments outside of the given specifications, or use outdoors or in a place exposed to direct sunlight.

2. Installation on equipment in conjunction with atomic energy, railways, air navigation, space, shipping, vehicles, military, medical treatment, combustion and recreation, or equipment in contact with food and beverages, emergency stop circuits, clutch and brake circuits in press applications, safety equipment or other applications unsuitable for the standard specifications described in the product catalog.

3. An application which could have negative effects on people, property, or animals requiring special safety analysis.

4. Use in an interlock circuit, which requires the provision of double interlock for possible failure by using a mechanical protective function, and periodical checks to confirm proper operation.



LECP1 Series / Controller Safety Instructions

Caution

1. The product is provided for use in manufacturing industries.

The product herein described is basically provided for peaceful use in manufacturing industries. If considering using the product in other industries, consult SMC beforehand and exchange specifications or a contract if necessary.

If anything is unclear, contact your nearest sales branch.

Limited warranty and Disclaimer/Compliance Requirements

The product used is subject to the following "Limited warranty and Disclaimer" and "Compliance Requirements".

Read and accept them before using the product.

Limited warranty and Disclaimer

1. The warranty period of the product is 1 year in service or 1.5 years after the product is delivered, whichever is first.*2)

Also, the product may have specified durability, running distance or replacement parts. Please

consult your nearest sales branch.

2. For any failure or damage reported within the warranty period which is clearly our responsibility,

a replacement product or necessary parts will be provided.

This limited warranty applies only to our product independently, and not to any other damage incurred due to the failure of the product.

3. Prior to using SMC products, please read and understand the warranty terms and disclaimers

noted in the specified catalog for the particular products.

***2) Vacuum pads are excluded from this 1 year warranty.**

A vacuum pad is a consumable part, so it is warranted for a year after it is delivered.

Also, even within the warranty period, the wear of a product due to the use of the vacuum pad or failure due to the deterioration of rubber material are not covered by the limited warranty.

Compliance Requirements

1. The use of SMC products with production equipment for the manufacture of weapons of mass destruction(WMD) or any other weapon is strictly prohibited.

2. The exports of SMC products or technology from one country to another are governed by the relevant security laws and regulation of the countries involved in the transaction. Prior to the shipment of a SMC product to another country, assure that all local rules governing that export are known and followed.

2. Outlines of Product

2.1 Features

Features of the controller.

- Actuator control

Servo control enables the positioning and the operation with a specified thrust of the actuator.

- Operation and settings are available with the controller.

Settings can be altered and operation can be run from the controller. Adjustments of the position, speed, acceleration and test runs are available without the teaching box, PC, and PLC.

- Operation with specified thrust

The holding force and pushing force of the actuator can be controlled in three steps.

- Separated power supply input

Power supply input is separated into the motor power supply and control power supply. Even if the power supply for the motor is turned off, the information of the encoder position is not lost while the control power supply is on, and parallel I/O control is available.

- Automatic sequence function of the returning to origin position

Returning to origin position is available through I/O signal combination.

- Alarm detection

Abnormal conditions are self-detected. Alarms are displayed by LED on the controller and abnormal conditions are output to the outside by the parallel I/O terminal.

- 14 points positioning / pushing is available

Through the combination of parallel I/O inputs, 14 points (position number 1 to 14(E)) of positioning / pushing are available. The speed and acceleration of the positioning can be set by the switch for each operating direction.

- Data input method

Parameter settings, test runs, and alarm resets can be performed by the controller.

Caution

When the device is set up or failure occurs, please refer to the operation manual of the actuator as well as this operation manual.

* Keep this operation manual accessible so it can be referred to when necessary.

2.2 How to Order

How to order is shown below.

Controller

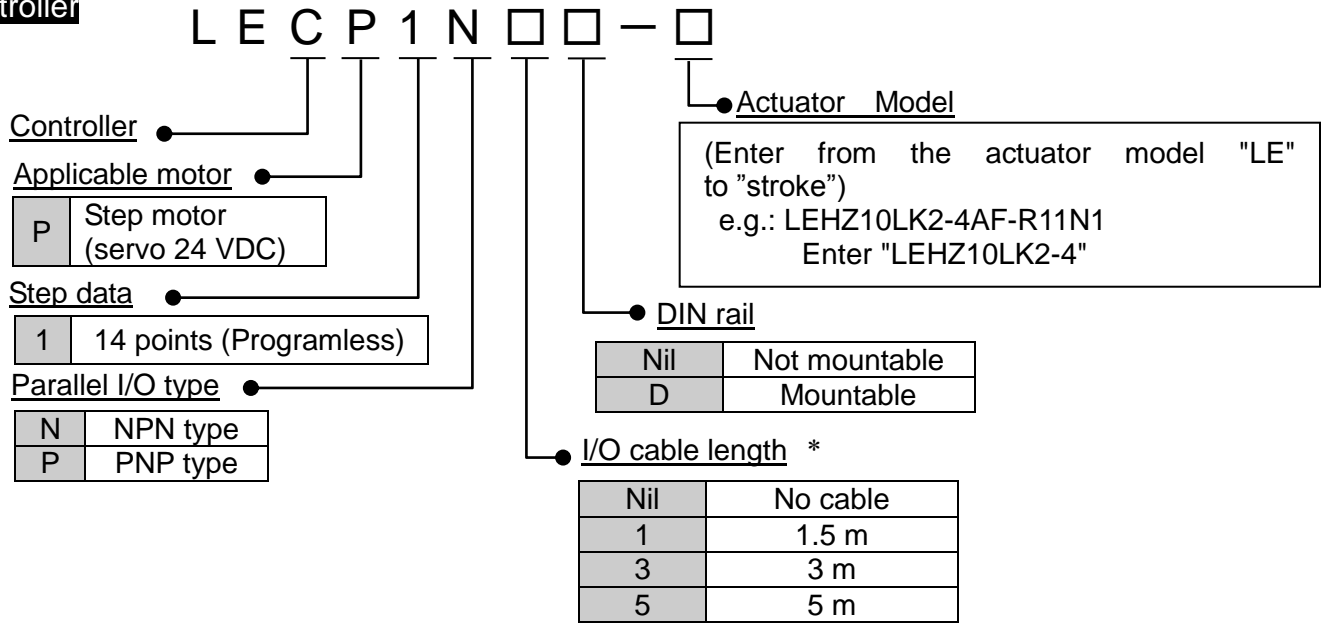

* 1.5 m power cable is included

Actuator + Controller

LEHZ10LK2-4AF-R11N1□

Actuator type ●

Fill in How to Order referring to How to Order of the catalog of Actuators.
Please refer to the table below for the applicable actuators.
e.g.: LEHZ10LK2-4AF-R11N1

Applicable actuators	
Electric gripper	LEH Series
Electric slide table	LES Series
Electric actuator / Rod type	LEY Series
Electric actuator / Slider type	LEF Series
Electric actuator / Rotary type	LER Series
Electric actuator / Guide rod Slider	LEL Series
Electric actuator / Miniature type	LEP Series
Electric actuator / Low profile slider type	LEM Series

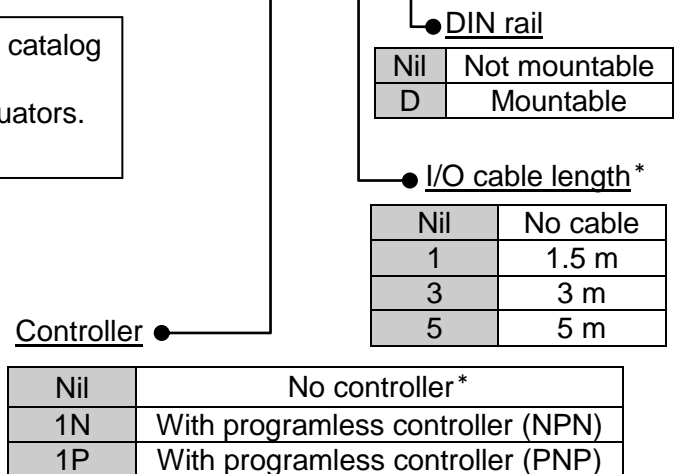

* If the actuator is ordered without the controller, the I/O cable type is not available.
LECP6 series I/O cables cannot be used due to different specification.

⚠ Caution

Single controllers are also shipped after setting the actuator specification parameters.
Confirm the combination of the controller and the actuator is correct.

2.3 Structure of the product

Structure of the controller.

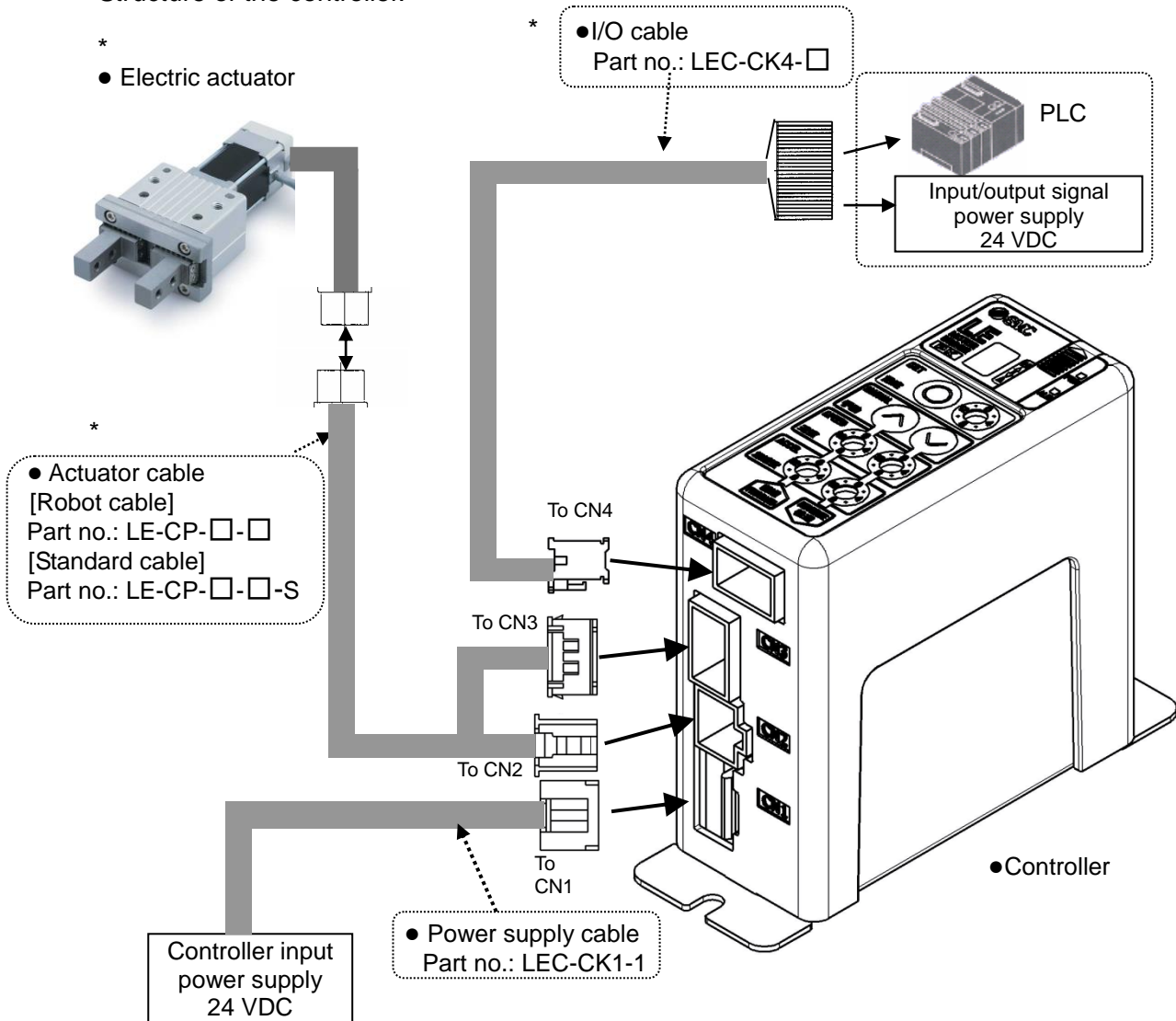

*When conformity to UL is required, the electric actuator and controller should be used with a UL1310 Class 2 power supply.

* These items are included when ordered using the part number for an actuator set.

Warning

Refer to **4. External connection** for wiring.

Refer to **13. Wiring of cables/Common precautions** when handling the wiring and cables.

2.4 Procedure (How to start the actuator)

Install, wire, set and operate the controller referring to the procedure below when the product is used for the first time.

(1) Checking the contents of the package

After unpacking everything, check the description on the label to identify the controller and the number of accessories.

Part's name	Quantity
Controller (LECP1□□-□)	1 pcs.
Power supply cable (LEC-CK1-1)	1 pcs.
I/O cable *(LEC-CK4-□)	1 pcs.
Actuator *	1 pcs.
Actuator cable * Robot cable: LE-CP-□-□ or Standard cable: LE-CP-□-□-S	1 pcs.

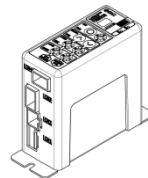

Controller

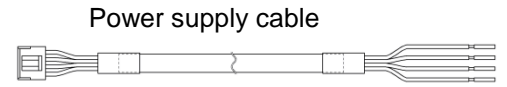

Power supply cable

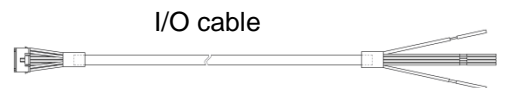

I/O cable

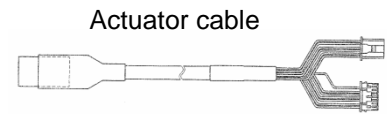

Actuator cable

* These items are included when ordered using the part number for an actuator set.

If parts are missing or damaged, please contact our distributor.

(2) Mounting the Controller

Refer to [3.4 Mounting](#) to mount the controller.

(3) Controller Wiring / Connection

Connect cables to the controller connectors (CN1 to CN4). Refer to [4. External connection](#) for the wiring of the cables.

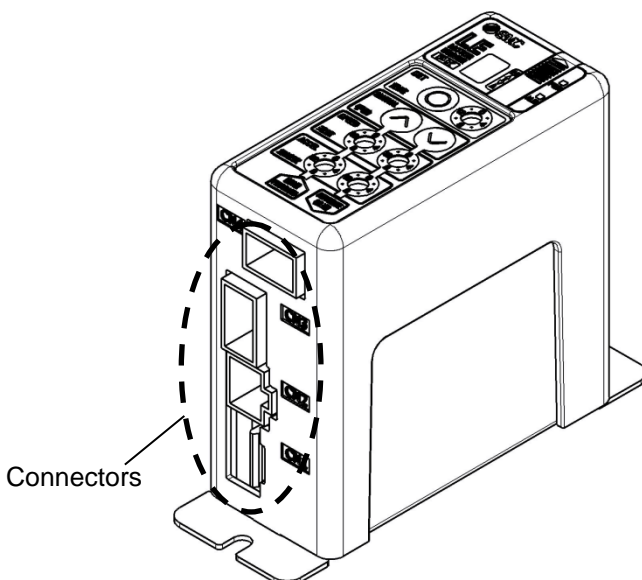

(4) Power supply ON, and the Alarm check

Supply power 24VDC.

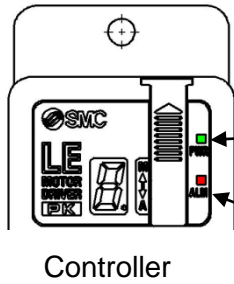

Description	LED turns on	Condition
PWR	Green LED is on	Servo is turned on
	Green LED is flashing	Servo is turned off
ALARM	Red	Alarm is generated

If the conditions are normal, the LED[PWR] on the front of the controller changes from a flashing to a solid light. The servo is turned on if the conditions are normal. If an alarm is generated, the LED [ALM] on the front of the controller lights up red.

Caution

When an alarm is generated

Confirm the content of the alarm with 7-segment LED of the controller or I/O output.

Eliminate the cause referring to **12. Alarm detection**.

(5) Data (Operation pattern) setting

Set the stop position, speed and acceleration per operating direction with the buttons and switches on the controller. Operations other than position setting, jog/inching can be performed after returning to origin position. Refer to **7. Setting method** for the details of settings.

(6) Test run

Test run is performed with the buttons and switches of the controller or I/O signal. Refer to **7.1 Setting procedure** and **6.3 Parallel input / output signal** for details.

3. Specifications

3.1 Basic specifications

Basic specifications of the product.

Item	Specifications
Controlled motor	Unipolar winding method 2-Phase HB step motor
Power supply specification (*1)	Power supply voltage: 24 VDC±10% (*2) *When conformity to UL is required, use UL1310 compliant Class 2 power supply unit for direct current.
Parallel input	Input 6 points (Photo coupler insulation)
Parallel output	Output 6 points (Photo coupler insulation)
Stop points	14 points (Location number 1 to 14(E))
Encoder	A/B phase, line receiver input specifications Pulse number: 800 pulse/rev
Memory	EEPROM
LED display	LED (Green/Red) 1 for each
7-segment LED display (*3)	1 digit, 7-segment display (red) Figures are expressed in hexadecimal (10 to 15 in decimal number are expressed as A to F)
Locked	With forced lock-release terminal
Cable length	I/O cable: 5 m or less Actuator cable: 20 m or less
Cooling method	Air-cooling type
Operating temperature range	0 to 40°C (No freezing)
Operating humidity range	90%RH or less (No condensation)
Storage temperature range	-10 to 60°C (No freezing)
Storage humidity range	90%RH or less (No condensation)
Insulation resistance	Between external terminals and case: 50MΩ (500 VDC)
Weight	130g (Mounting screw type), 150g(DIN rail mounting type)

*1) Do not use inrush current suppressor type as the power supply for the controller input.

*2) Power consumption depends on actuator. Please refer to the operation manual of actuators for details.

*3) "10" to "15" in decimal number are displayed as follows in the 7-segment LED

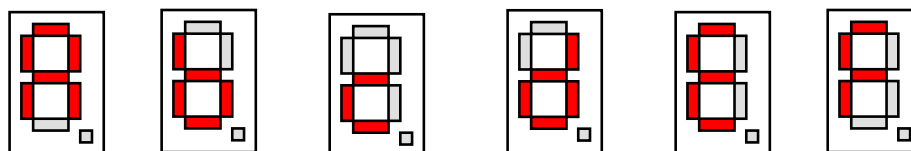

Decimal display

10

11

12

13

14

15

Hexadecimal display

A

b

c

d

E

F

3.2 Details of the controller

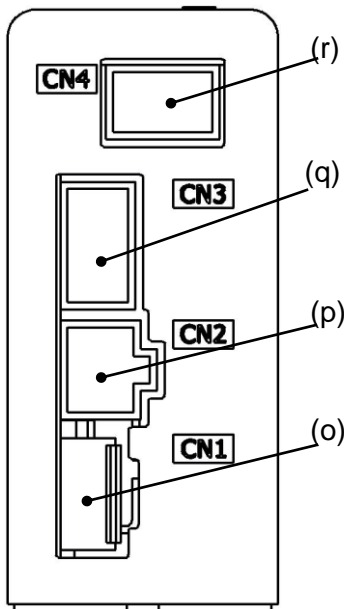
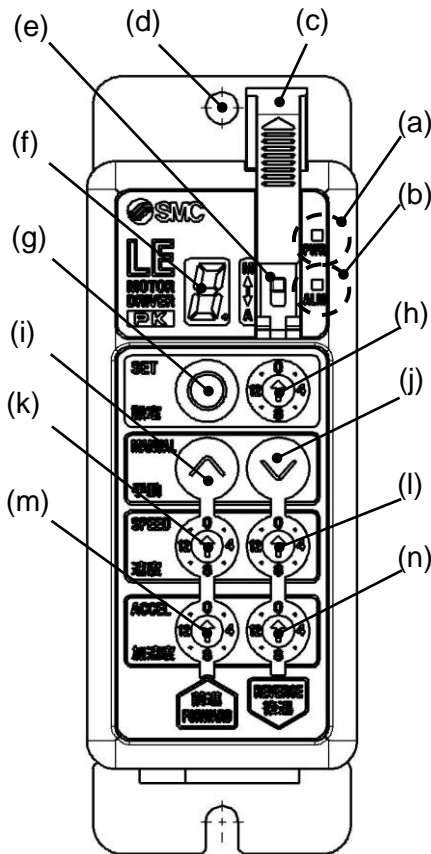

No.	Display	Description	Details
(a)	PWR	Power supply LED	Power supply ON/No alarm: Green turns on Power supply ON/Servo OFF: Green flashes
(b)	ALM	Alarm LED	Power supply ON/With alarm: Red flashes Power supply ON/Parameter setting: Red flashes
(c)	—	Cover	Protection for the change in the mode using the mode switch (Close the cover after changing the SW position).
(d)	—	FG	Frame ground (Tighten the bolt with the nut when mounting the controller. Connect the grounding cable.)
(e)	—	Mode switch	Changes the mode (Manual mode <-> Auto mode)
(f)	—	7-segment LED	Displays the stop position, value set using the position switch (h), and alarm information.
(g)	SET	Set button	Determines the settings and gives a command to operate in manual mode.
(h)	—	Position switch	Assigns the position to drive (1 to 14) and the origin (15)
(i)	MANU AL	Forward button	Performs forward jog and inching.
(j)		Reverse button	Performs reverse jog and inching.
(k)	SPEED	Forward speed switch	16 forward speeds are available. *1)
(l)		Reverse speed switch	16 reverse speeds are available *1)
(m)	ACCEL	Forward acceleration switch	16 forward acceleration steps are available. *1)
(n)		Reverse acceleration switch	16 reverse acceleration steps are available. *1)
(o)	CN1	Power supply connector	Power supply cable is connected.
(p)	CN2	Motor driving connector	Motor connector of the actuator cable is connected.
(q)	CN3	Encoder connector	Encoder connector of the actuator cable is connected.
(r)	CN4	I/O connector	I/O cable is connected.

*1) The Set value of speed and acceleration are set for back and forth directions. The set value will be reflected in the operation of all position numbers.

⚠ Caution

Use a flat blade watchmaker's screwdriver of the size shown below when changing position switch (h) and the set value of the speed/acceleration switches (k) to(n).

<Size>

End width L : 2.0 to 2.4 [mm]

End thickness W : 0.5 to 0.6 [mm]

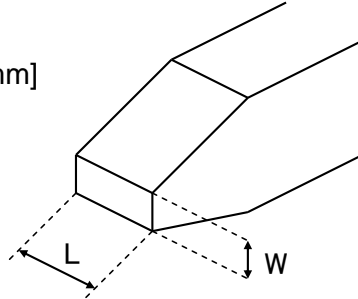

Magnified view of the end of the flat blade screwdriver

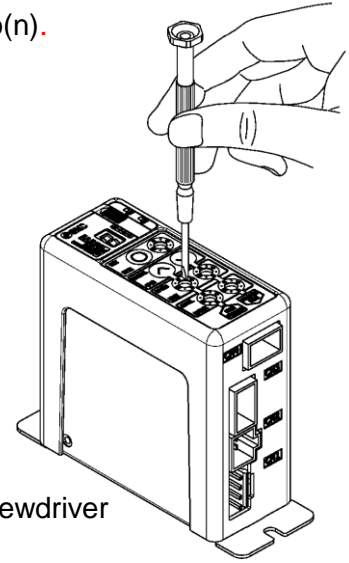

3.3 Outer dimensions

The appearance of the product is shown below.

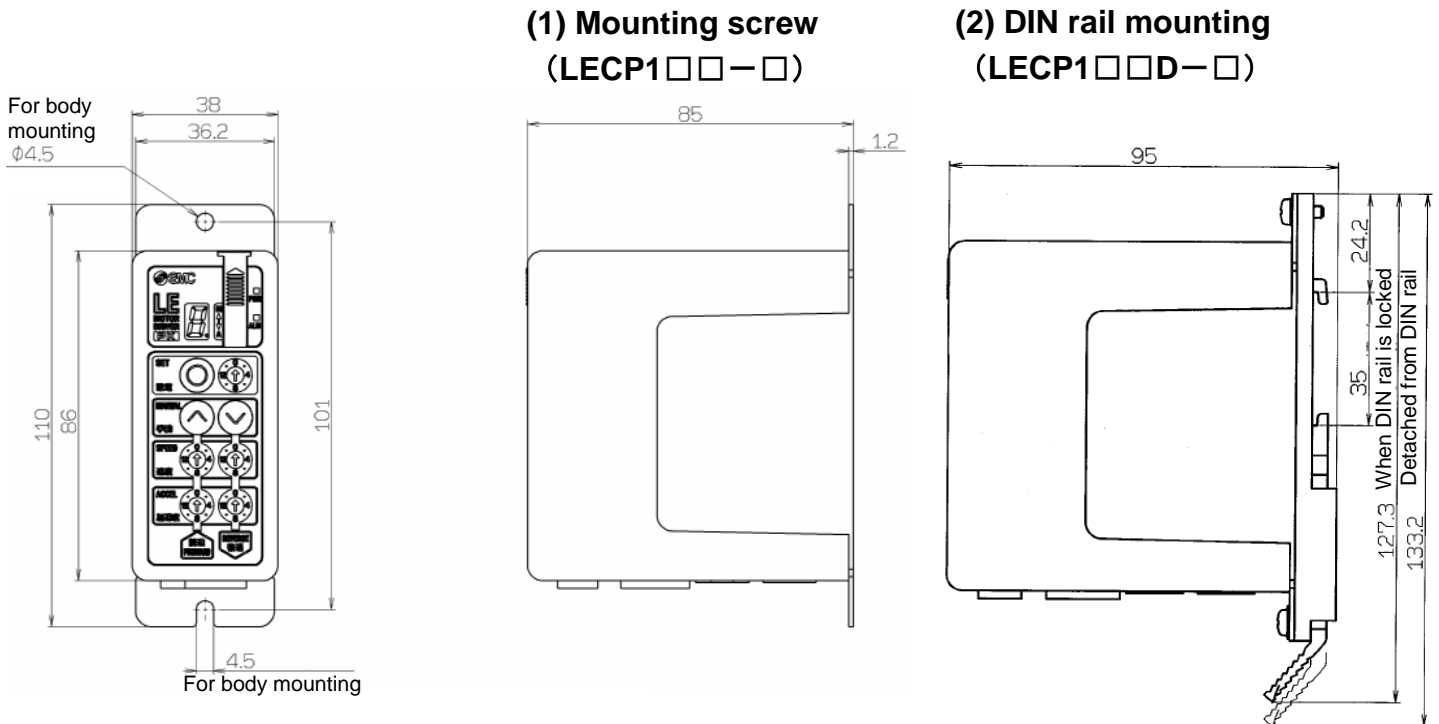

3.4 Mounting

(1) Mounting

Controller mounting methods are shown below.

(1) Screw mounting (LECP1□□-□) (Mounting with two M4 screws)

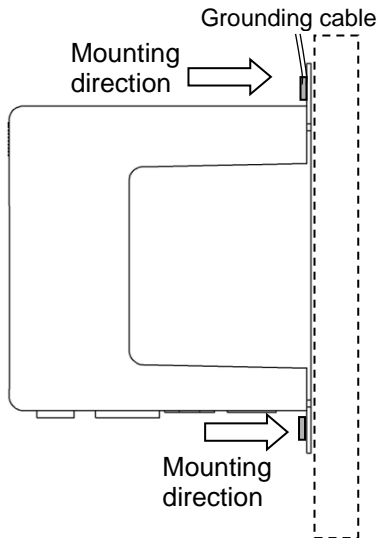

(2) DIN rail mounting (LECP1□□D-□)

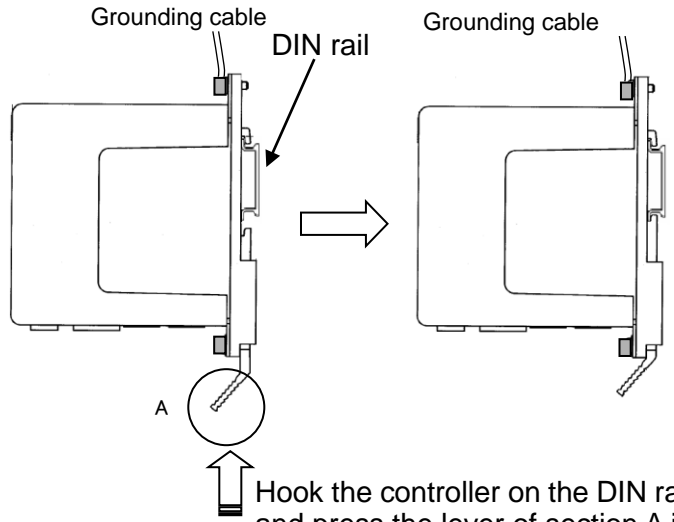

Hook the controller on the DIN rail and press the lever of section A in the arrow direction to lock it.

(2) Connection to ground

Tighten the bolt with the nut when mounting the ground cable as shown below.

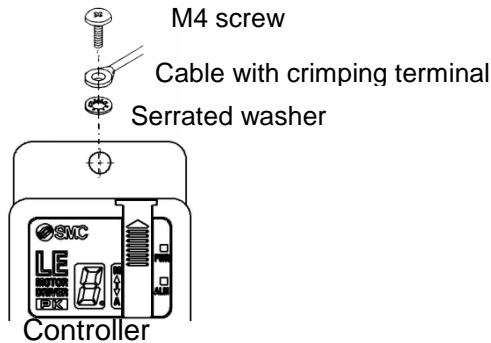

! Caution

- M4 screws, cable with crimping terminal and serrated washer are prepared by customer.
- Ground the controller to reduce noise.
- Controller attaching hole (Installation position of grounding cable) and SG (Signal ground) are connected in the controller. Please do not ground the controller when using it in the plus earth environment.

⚠ Caution

- (1) A dedicated Ground connection must be used. Use a D-class ground connection (ground with a resistance of less than 100Ω).
- (2) The cross sectional area of the grounding cable shall be 2mm² or more. Grounding location shall be in the vicinity of the controller. Keep the grounding cable short.
- (3) The controller case mounting part is connected to 0V of the power supply.

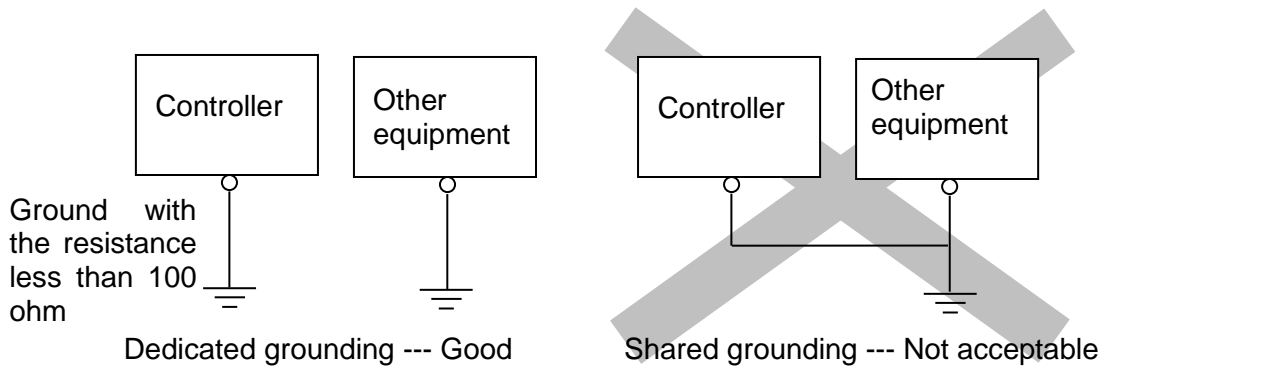

(3) Location for mounting

Select the size and the installation style so that the surrounding temperature of the controller is 40°C or less. Mount the controller vertically on the wall as shown. Leave a minimum of 30 mm of clearance at the top of the controller or 60 mm below the controller so that the cables can be connected and disconnected. Keep 60mm or more between the front of the controller and the cover (lid) so that buttons and switches can be operated. Keep enough space around the controller so that the operating temperature of the controller stays within the specification range. Avoid mounting the controller near a vibration source, such as a large electromagnetic contactor or circuit fuse breaker on the same panel.

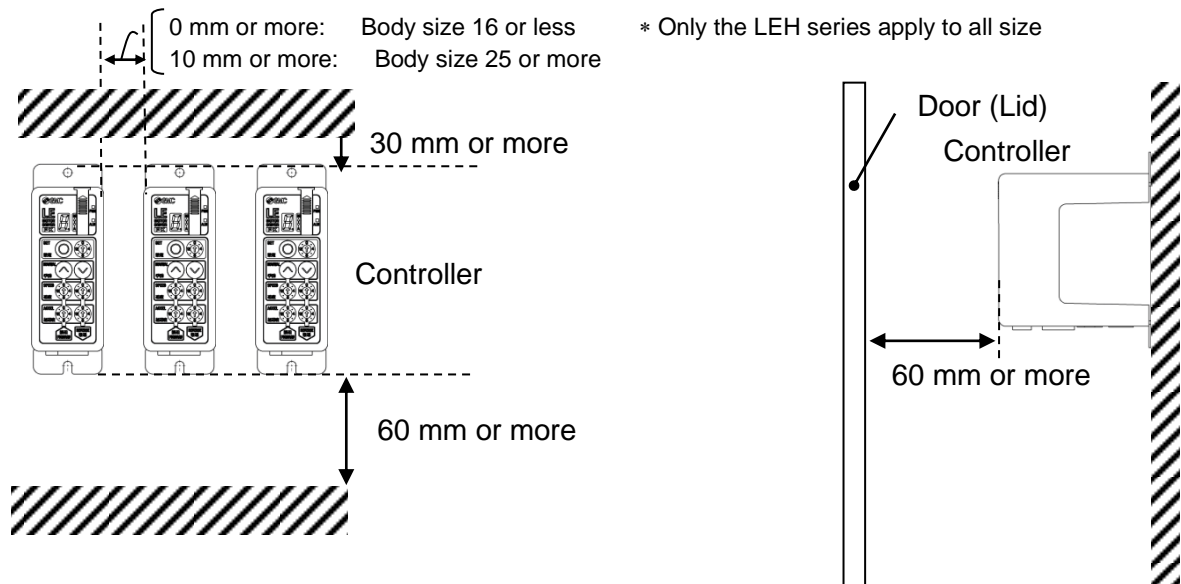

⚠ Caution

When there are dents, bumps or warping on the mounting surface of the controller, excessive force can be applied to the case, which can cause failure. Mount on a flat surface.

4. External connection

4. 1 CN1: Power supply connector

Examples of standard wiring are shown for each connector (CN1 to CN4) of the controller.

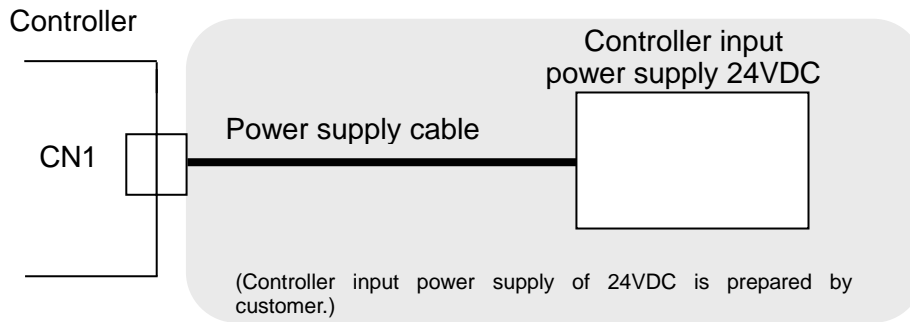

Refer to **5. CN1: Power supply cable** for wiring.

Caution

Do not use inrush current suppressor type as the power supply for the controller input.

4. 2 CN2: Motor power connector, CN3: Encoder connector

Connect the controller and the actuator with the actuator cable (LE-CP-□-□ or LE-CP-□-□-S).

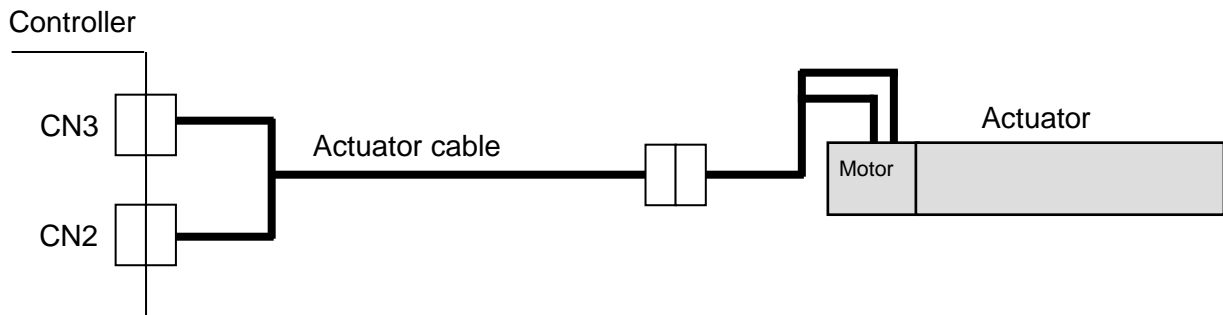

4. 3 CN4: Parallel I/O connector

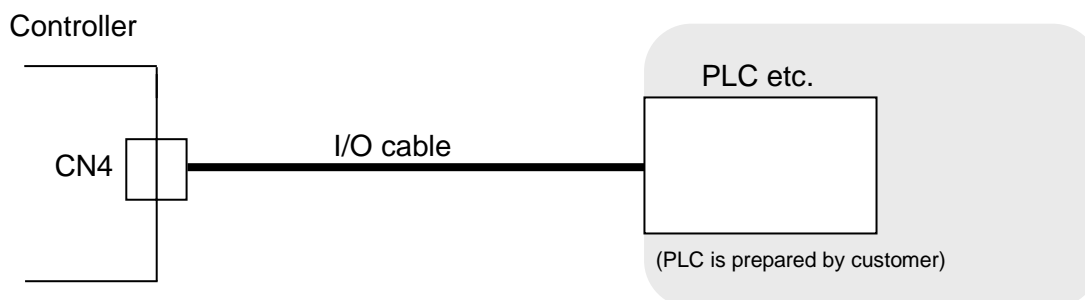

* Refer to **6.4 Parallel I/O connector wiring (Example)** for wiring.

* Refer to **6.3 Parallel input / output signal** for the details of parallel input / output signals.

5. CN1: Power supply cable

5.1 Power supply cable specification

Included power supply cable specification is shown below.

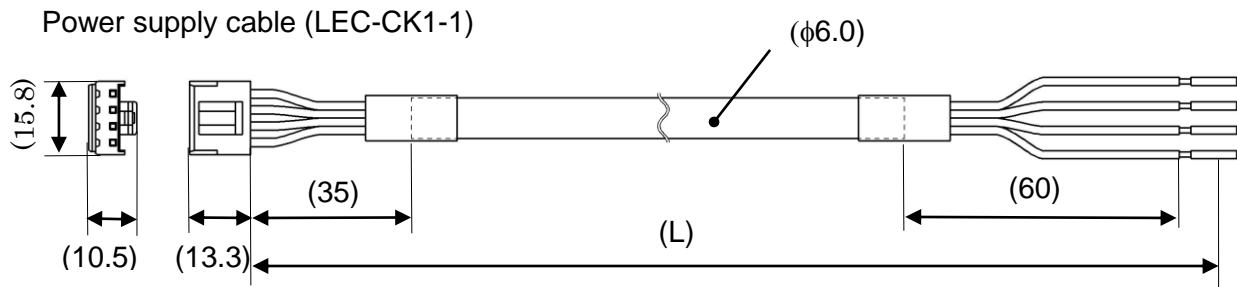

Item	Specifications
Connector	Manufacturer: J.S.T. Mfg. Co.,Ltd. Product number :VHR-4N
Cross sectional area of the cable	AWG20
Length (L)	LEC-CK1-1:1.5m only

Terminal	Color of covered wire	Function	Functional explanation
0V	Blue	Common power supply (-)	Negative common power for M24V, C24V, and BK RLS.
M24V	White	Power supply of motor (+)	Positive power for the motor to be supplied via the controller.
C24V	Brown	Control power (+)	Positive control power to be supplied to the controller.
BK RLS	Black	Unlocking (+)	Positive power for lock release. Connected to the M24V in the controller internal circuit.)

5.2 Wiring of power supply cable

Referring to (1) to (4), connect the power supply cable included in accessories to the controller input power supply 24VDC and insert it to the controller CN1 power supply connector.

(1) Wiring of power supply

Connect the positive side (+) of the controller input power supply 24VDC to the C24V and M24V terminals of the power supply cable, and connect the negative side (-) to the 0V terminal.

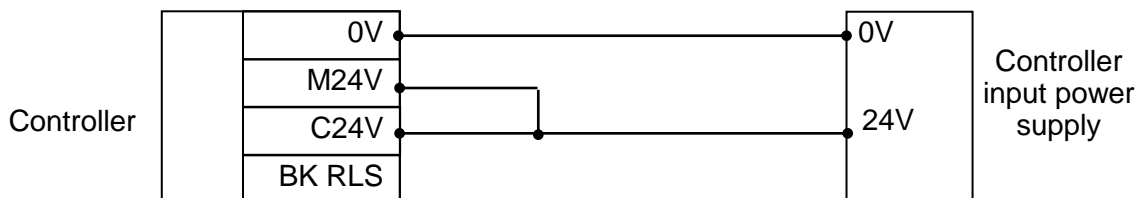

⚠ Caution

Do not use the power supply of "inrush current prevention type" for the controller power supply (24VDC).

(2) Wiring of forced unlocking switch

When manual unlock is required for adjustment or reset of the actuator with lock, please install a switch. * The switch (24V DC, contact capacity: 0.5A or more) needs to be prepared by the user.

One side of the switch should be connected to the positive side of the controller input power supply 24V DC, and the other side should be connected to the BK RLS terminal of the power supply plug. When the switch is closed, the controller/motor is forcibly unlocked.

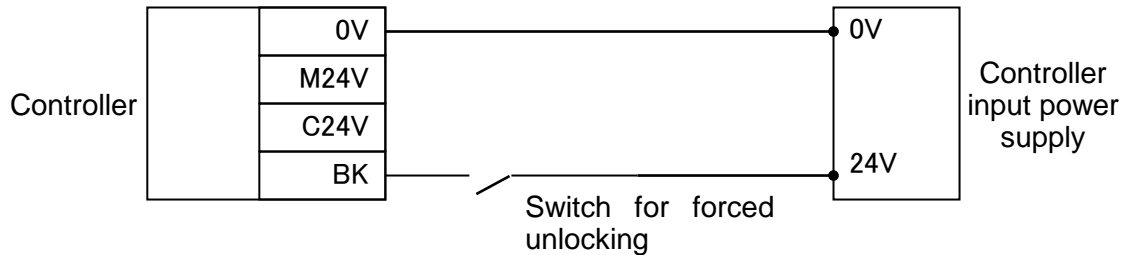

Caution

For the actuator without lock, please do not connect the BK RLS terminal.

The only case where 24V DC can be applied to the BK RLS terminal is as described below, 24V DC should not be applied in other cases.

- STOP command (CN4 14pin STOP) is turned ON and Servo is turned OFF.
- When the control power supply (C24V) is shut off.

(3) Stop the power supply for the motor

If it is necessary to shut off the power supply for the motor from outside, connect the relay between the input power supply for the controller 24VDC and the power supply plug for the controller M24V. (Refer to the wiring diagram in the next page.)

The motor power supply should be shut off after the STOP command (CN4 14pin STOP) is turned ON. Refer to 6.3 Parallel input signals for the STOP command.

Warning

- Do not perform return to origin when the the motor drive power (M24V) is disconnected. The controller cannot recognize the correct origin point if a return to origin instruction is made with the motor drive power (M24V) disconnected.
- If the M24V is shut off during actuator operation, there will be an additional delay experienced before it stops (the stop distance will be extended) due to inertia of work pieces or regenerated energy. When the M24V is turned off, and the the STOP command is turned ON (CN4 14pin STOP) simultaneously the the time to stop can be shortened.
- If the motor drive power is shut off during vertical stop, the table may drop due to brake response.
- BK RLS is internally connected to the M24V in the controller, so please do not apply 24V DC to the BK RLS terminal when the M24V is shut off.

【Example of the circuit】 *The figure below shows the stopped state.

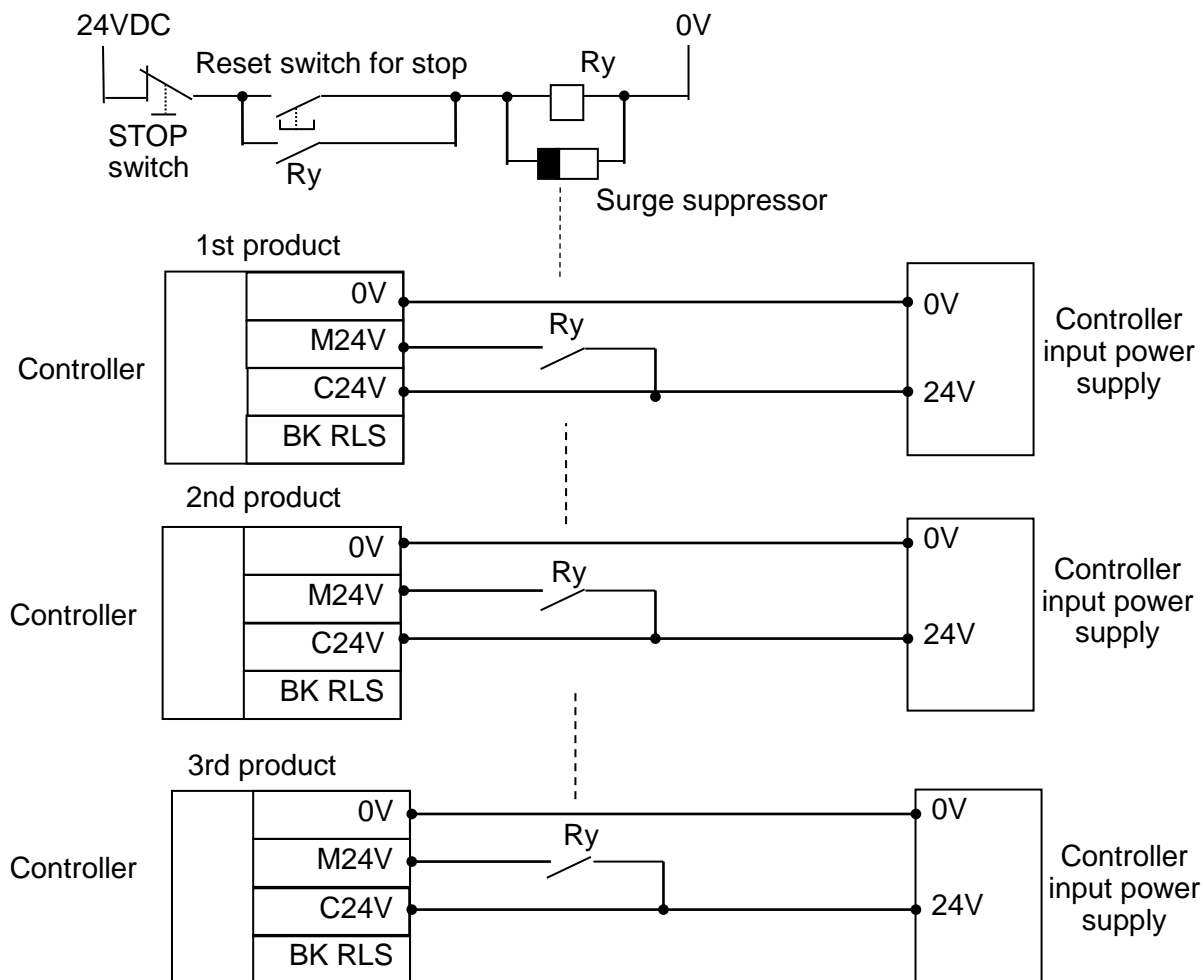

6. CN4: Parallel I/O cable

6.1 Parallels input / output

■ Input specifications

No.	Item	Specifications
1	Input circuit	Internal circuit and the photo coupler insulation
2	No. of inputs	6 inputs
3	Voltage	24 VDC±10%
4	Input current at ON	3.5 mA±20% (at 24 VDC)
5	Input current / voltage at OFF	Current: 1.5 mA or less Voltage: 11 V or less

■ Output specifications

No.	Item	Specifications
1	Output circuit	Internal circuit and the photo coupler insulation
2	No. of outputs	6 outputs
3	Maximum voltage between terminals	30 VDC
4	Maximum output current	10 mA
5	Saturation voltage between terminals	2.0 V (Maximum)

6.2 Parallel input / output circuit (NPN, PNP)

There are two types of parallel input / output types for this controller as shown below.

NPN type (LECP1N□□-□)

PNP type (LECP1P□□-□)

(1) Parallel I/O input circuit (NPN, PNP common)

■ NPN TYPE

(a)	"COM+" <1>
(b)	IN0 <9> to STOP <14>

■ PNP TYPE

(a)	"COM-" <2>
(b)	IN0 <9> to STOP <14>

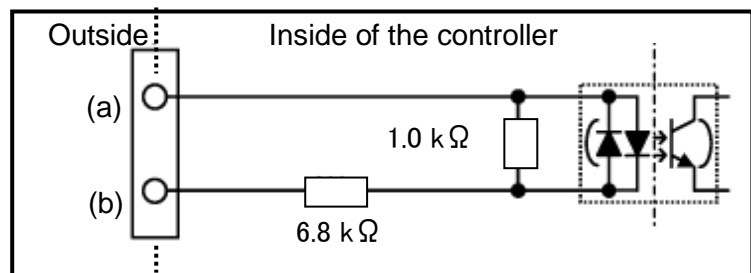

(2) Parallel I/O output circuit

NPN TYPE

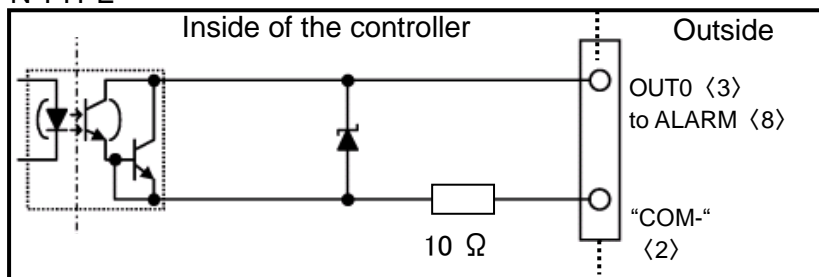

PNP TYPE

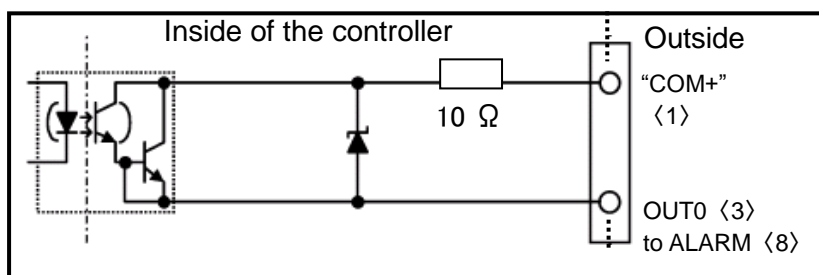

6.3 Parallel input / output signal

(1) Parallel I/O cable (LEC-CK4-□)

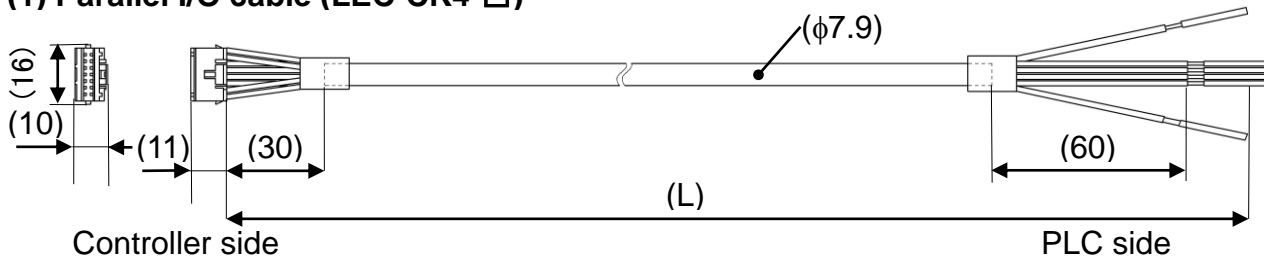

Item	Specifications
Connector	Manufacturer: J.S.T. Mfg. Co.,Ltd. Product number:PADP-14V-1-S
Cross sectional area of the cable	AWG26
Length (L)	The suffix of the part number (1,3,5) specifies the length. LEC-CK4-1: 1.5 m, LEC-CK4-3: 3 m, LEC-CK4-5: 5 m

(2) Details of input/output signal

Terminal No.	Insulation color	Dot Mark	Dot color	Function	Contents								
1	Light brown	■	Black	COM+	Connect the 24V side of the power supply (24VDC) for input / output signal.								
2	Light brown	■	Red	COM-	Connect the 0V side of the power supply (24VDC) for input / output signal.								
3	Yellow	■	Black	OUT0	Operation completion output (Output with the combination of OUT0 to 3) Example: (Output the operation completion of position No. 3) <table border="1" style="margin-left: 20px;"> <tr> <td>OUT3</td> <td>OUT2</td> <td>OUT1</td> <td>OUT0</td> </tr> <tr> <td>OFF</td> <td>OFF</td> <td>ON</td> <td>ON</td> </tr> </table>	OUT3	OUT2	OUT1	OUT0	OFF	OFF	ON	ON
OUT3	OUT2	OUT1	OUT0										
OFF	OFF	ON	ON										
4	Yellow	■	Red	OUT1									
5	Light green	■	Black	OUT2									
6	Light green	■	Red	OUT3									
7	Grey	■	Black	BUSY	BUSY signal (Output during operation)								
8	Grey	■	Red	ALARM	ALARM signal N.C. (Turned off during alarm is being generated or when servo is turned off)								
9	White	■	Black	IN0	- Operation command input (Input with the combination of IN0 to IN3) ^{Note 1} - Return to origin command input (Turn on IN0 to 3 simultaneously) Example: (Commands position No. 5 to operate) <table border="1" style="margin-left: 20px;"> <tr> <td>IN3</td> <td>IN2</td> <td>IN1</td> <td>IN0</td> </tr> <tr> <td>OFF</td> <td>ON</td> <td>OFF</td> <td>ON</td> </tr> </table>	IN3	IN2	IN1	IN0	OFF	ON	OFF	ON
IN3	IN2	IN1	IN0										
OFF	ON	OFF	ON										
10	White	■	Red	IN1									
11	Light brown	■ ■	Black	IN2									
12	Light brown	■ ■	Red	IN3									
13	Yellow	■ ■	Black	RESET	Interruption or alarm reset During operation: The speed is reduced from the point where signal is input until the actuator stops. (Servo stays ON) Alarm is being generated: Alarm reset								
14	Yellow	■ ■	Red	STOP	STOP command (Sudden deceleration to turn off servo)								

* Parallel I/O signal is valid in auto mode. STOP signal is valid in auto mode and manual mode.

During manual mode, input signals except STOP is invalid. All output signals are OFF.

During manual mode testing, output signals are valid (input signals other than STOP are invalid).

Note1) The following table shows the relation of the position number and the combination of IN0-IN3 or OUT0-OUT3.

○:OFF ●:ON

Position number	IN3	IN2	IN1	IN0
1(End side)	○	○	○	●
2(Motor side)	○	○	●	○
3	○	○	●	●
4	○	●	○	○
5	○	●	○	●
6	○	●	●	○
7	○	●	●	●
8	●	○	○	○
9	●	○	○	●
10 (A)	●	○	●	○
11 (B)	●	○	●	●
12 (C)	●	●	○	○
13 (D)	●	●	○	●
14 (E)	●	●	●	○
Origin(F)	●	●	●	●

○:OFF ●:ON

Position number	OUT3	OUT2	OUT1	OUT0
1(End side)	○	○	○	●
2(Motor side)	○	○	●	○
3	○	○	●	●
4	○	●	○	○
5	○	●	○	●
6	○	●	●	○
7	○	●	●	●
8	●	○	○	○
9	●	○	○	●
10 (A)	●	○	●	○
11 (B)	●	○	●	●
12 (C)	●	●	○	○
13 (D)	●	●	○	●
14 (E)	●	●	●	○
Origin(F)	●	●	●	●

(3) The change of I/O output signal under the condition of controller at auto mode.

Condition of the controller	Output signal					
	OUT0	OUT1	OUT2	OUT3	BUSY	ALARM
Right after supplying power	OFF	OFF	OFF	OFF	OFF	OFF
After supplying power and at the stop before returning to origin position	OFF	OFF	OFF	OFF	OFF	ON
During the returning to origin position, positioning, and pushing operation.	OFF	OFF	OFF	OFF	ON	ON
When return to origin position is completed.	ON	ON	ON	ON	OFF	ON
When positioning operation or pushing operation is completed.	*1	*1	*1	*1	OFF	ON
Stopped by RESET command	OFF	OFF	OFF	OFF	OFF	ON
Stopped by STOP command	*2	*2	*2	*2	OFF	OFF
When alarm is generated	OFF	*3	*3	*3	OFF	OFF

*1 ON, OFF of OUT0 to 3 depends on the target position

*2 The value is not decided. (It depends on the controller status (Operation/Stopped) when STOP command is input.)

*3 ON and OFF of OUT0 to 3 depends on the alarm group.

There is no servo ON signal with this controller. The servo turns off when conditions to turn off the servo are satisfied. Refer to **8.5 Servo ON** for details.

⚠ Caution
<ul style="list-style-type: none"> • IN0 to IN3 input during the switching from manual mode to auto mode are invalid. IN0 to IN3 become valid after the auto mode is set up. • Output signal are not output from parallel I/O right after switching from manual mode to auto mode. Output signal will be output from parallel I/O after inputting the next command. • Output from I/O is not made if switching from auto mode to manual mode.

6.4 Parallel I/O connector wiring (Example)

Use an I/O cable (LEC-CK4-□) when connecting to PLC and CN4 parallel I/O connectors. Wiring depends on the parallel input/output type of the controller (NPN or PNP). Perform wiring referring to the wiring diagram below.

■NPN TYPE

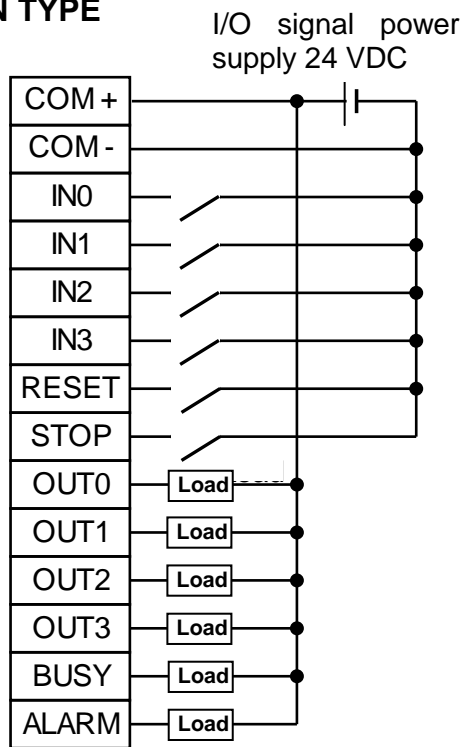

■PNP TYPE

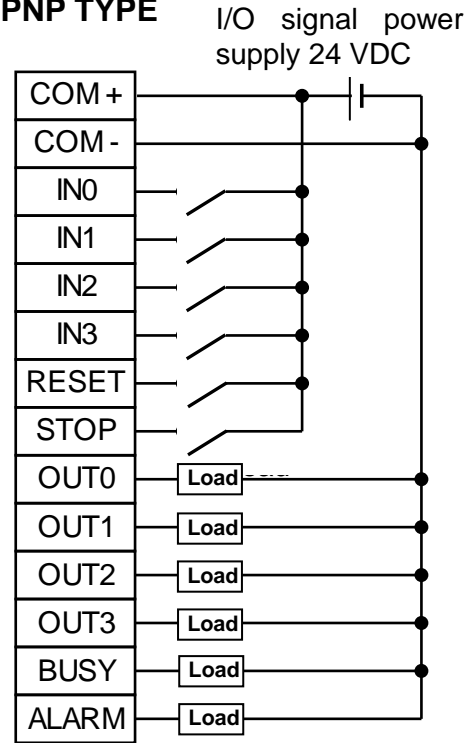

⚠ Caution

Prepare separate 24VDC power supplies for the CN1 controller input power supply and CN4 input / output signal power supply.

7. Setting method

It is necessary to set the stop position and operation method using the controller in order to move the actuator to the specified position. Set data is stored in the memory in the controller

Up to 14 points can be set. Set "1" to "14" with the position switch (h). ("1" to "9", "A" to "E") is displayed in hexadecimal on the 7-segment LED (f).

There are 2 types of modes on the controller (manual mode, auto mode). Setting and operating methods are different. Mode is switched by mode Switch (e).

Upper part of the right figure(M) : Manual mode

Lower part of the right figure(A) : Auto mode

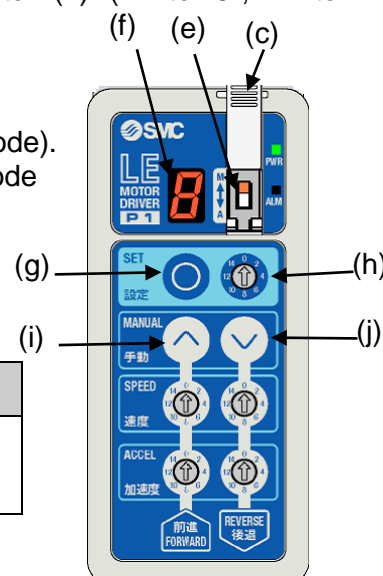

Caution

Close the cover (c) after the switching the mode to avoid unexpected mode changes.

	Manual mode(M)	Auto mode(A)
Setting of stop position (step data)	○	×
Setting of Speed and Acceleration	○	△(Only in speed adjustment)*2
Setting of operation method	○	×
Setting of parameters	○	×
Controller operation using the button	○	×
Operation from parallel I/O	×	○
Positioning operation	○	○
Pushing operation	△(Test function only)*1	○
Output to parallel I/O	△(Test function only)*1	○
Check the presence of alarm	○	○
Check the content of alarm	○	○
How to release the alarm	Press set button (g)	Turn on RESET or press set button (g)
Servo OFF method	Press Forward button (i) and Reverse button (j) simultaneously for 3 sec.	Turn on STOP

*1 Refer to [7.4 Test function](#) for details of test function.

*2 Refer to [7.3 Controller modes](#) for details of the adjustment of the speed.

7.1 Setting procedure

Follow the procedure below for setting.

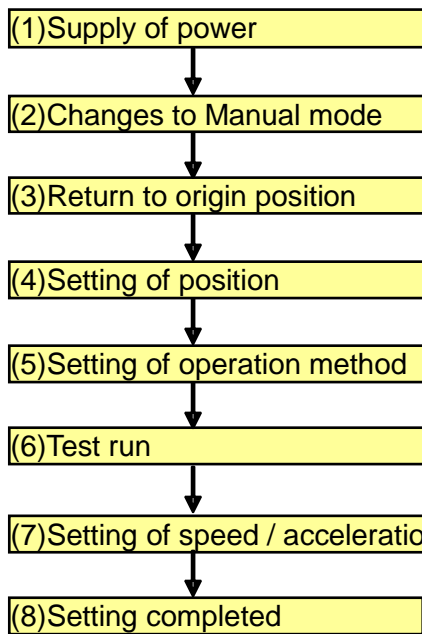

Repeat the same procedure for all points you would like to set.

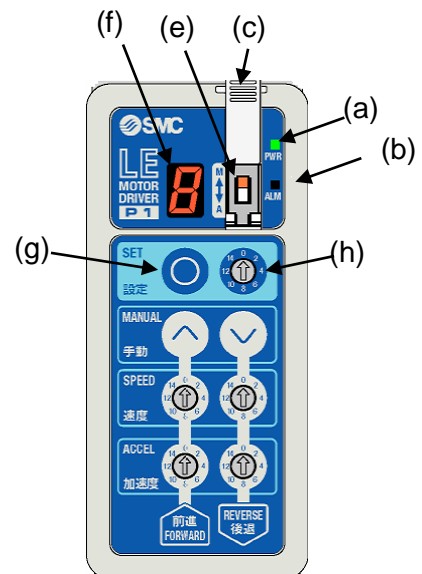

(1) Supply of power

Apply 24 VDC to the power supply for the power line and the signal line. (*) After applying the power, confirm that the power supply LED (a) lights green (= Servo ON). Refer to **8.5 Servo ON** if the power supply LED (a) flashes green.

When alarm LED (b) lights up, refer to section **12. Alarm Detection**

(* After supplying power, it may take approximately 10 seconds until ALARM is output depending on the actuator positions.)

(2) Changes to Manual mode

Switch the controller mode switch (e) to manual mode (M side). In manual mode, the 7-segment LED (f) indicates the value of the position switch (h) with high speed flashing.

(3) Return to origin

Confirm that the 7-segment LED (f) display is changed to "F" by setting the position switch (h) to "15", then press the set button (g) to start the return to origin. When the return to origin is completed, the display of the 7-segment LED (f) changes from flashing to solid.

⚠ Caution

- If return to origin is performed before the servo is turned on (Power supply LED (a) lights up green), an alarm will be generated. Perform the return to origin after confirming that the servo is turned on.
- Refer to **8.1 Return to origin** for details.
- The direction of return to origin depends on the actuator. Refer to **10. Initial setting value per actuator** for the default setting.

(4), (5) Setting of position and operation method

At the manual mode after returning to origin, position can be set by (A) Jog / inching or (B) Direct teaching. Example) Setting of position number 3

(A) Setting by Jog / inching

- [1] Set the position switch (h) to the required position ("3" in this case). The value of position switch (h) flashes in high speed on 7-segment LED (f)

*Do not set "0" and "F(15)", They are not available for position numbers.

- [2] Confirm that the power supply LED (a) is lit up, then, press the set button (g) to move the actuator to the previous set position.

The 7-segment LED (f) light is solid when the actuator reaches the set position.

Then, keep pressing the set button (g) until the 7-segment LED (f) display starts flashing slowly.

* If set button (g) is pressed again during moving, the moving to the set position is stopped.

Moving to the registered position starts by pressing set button (g) again.

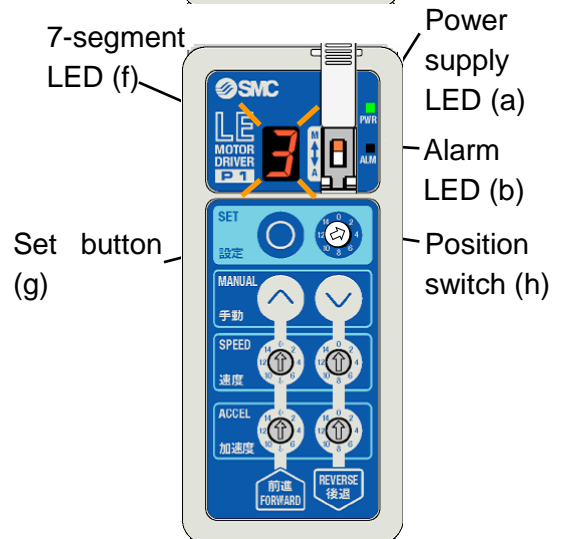
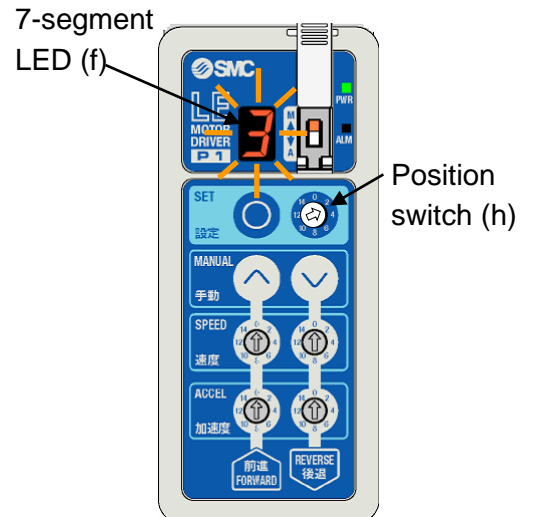

! Caution

- If the return to origin is performed before step [2], alarm is generated (7-segment LED (f) displays [C], and the alarm LED (b) lights up). In this case, reset the alarm by pressing the set button (g). Then, set the position switch (h) to [F (15)] and perform return to origin by pressing the set button (g) before performing the step [2].
- If it is not possible to return to the position before setting due to the mechanical interference, set the position by (B) Direct teaching.

[3] Perform Jog / inching using Forward button (i) and Reverse button (j) to move to desired position.

- * Inching starts by pressing either the Forward button (i) or Reverse button (j).
- * Jog starts by keeping pressing Forward button (i) or Reverse button (j). Refer to **8.4Jog/ inching operation** for details.



[4] Lock in the position by pressing the set button (g). At this point, the value has not been stored. If the power supply is cut, it is necessary to start from step [1] again.

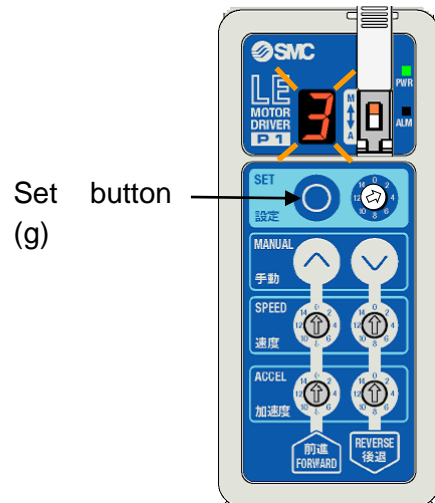

[5] Set the operation method of this position by pressing Forward button (i) or Reverse button (j) monitoring 7-segment LED (f)

- * Actual force of pushing force depends on the actuator. Refer to **10.Initial setting value per actuator** Pushing operation may not be possible depending on the actuator.

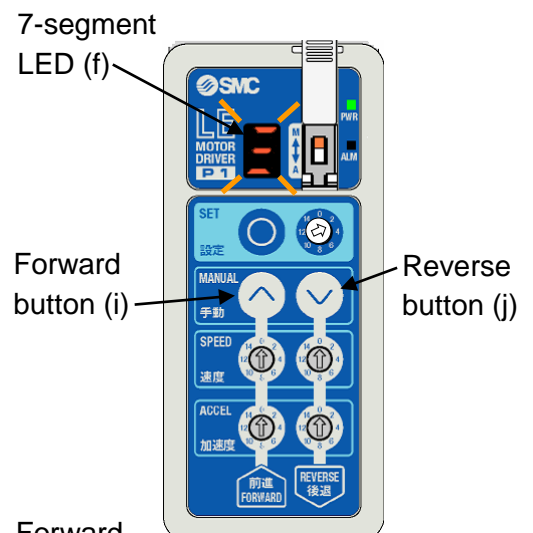

7-segment LED display (Set operation method)

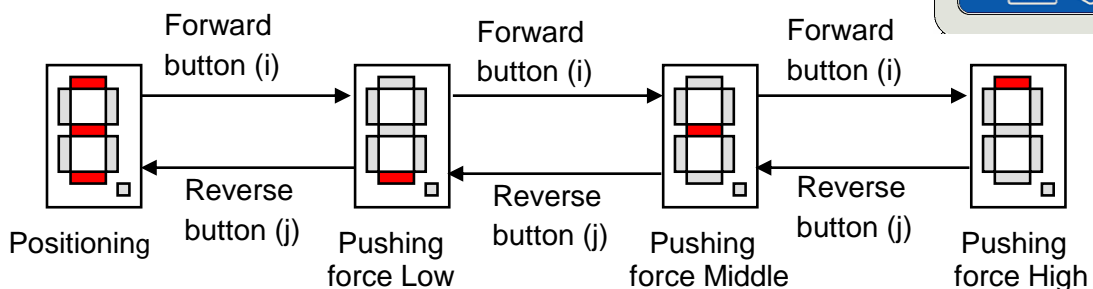

[6] Press button (g) for 2 sec. to set the operation method. When this operation completes, the position set in 7-segment LED (f) is displayed.

* When the position is registered and set button (g) is released, 7-segment LED (f) flashes rapidly.

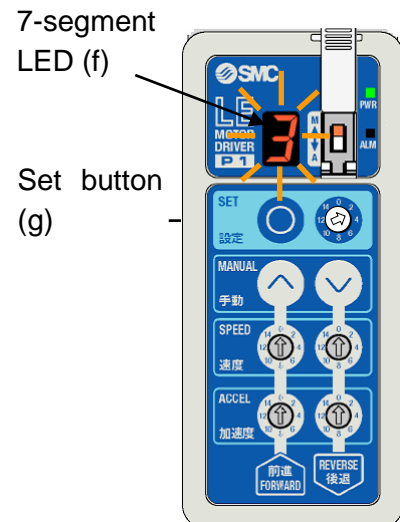

Positioning by jog / inching completed. Perform the same procedure for other required position numbers.

⚠ Caution

- If jog / inching is performed before the servo is turned on (Power supply LED (a) lights up green), an alarm will be generated. Perform the jog / inching after confirming that the servo is turned on.
- Set operation method per position number. Refer to **8. Operations**.

(B) Setting by direct teaching (Ex. Position switch initial value "4")

[1] Pressing the Forward button (i) and Reverse button (j) simultaneously for 3 seconds, then the power supply LED (a) will be changed from lighting to flashing and 7-segment LED (f) will be changed from flashing to lighting.

* The flashing of the power supply LED (a) indicates the servo is turned off.

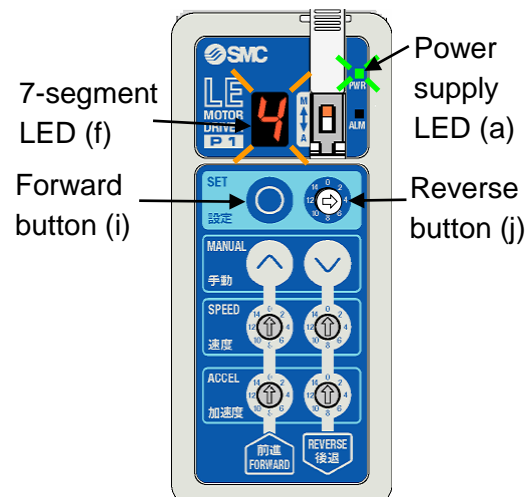

⚠ Caution

- If the servo of the direct teaching is turned OFF by the actuator with lock, the lock will be released as well. Therefore, if an actuator with lock is used vertically, the moving part of the actuator may drop due to the weight of the actuator itself.

[2] Set the position switch (h) to the required position ("3" in this case). The value of the position switch (h) flashes on the 7-segment LED (f).

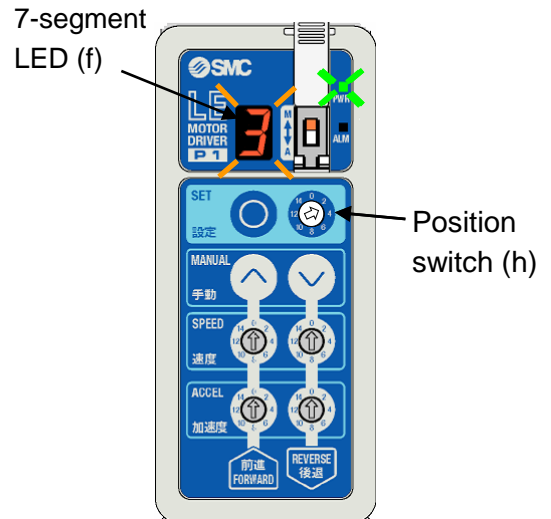

* Do not set "0" and "F (15)", They are not position numbers.

[3] Press and hold the set button (g) until the 7-segment LED (f) changes from solid to slow flashing, then, release the set button (g).

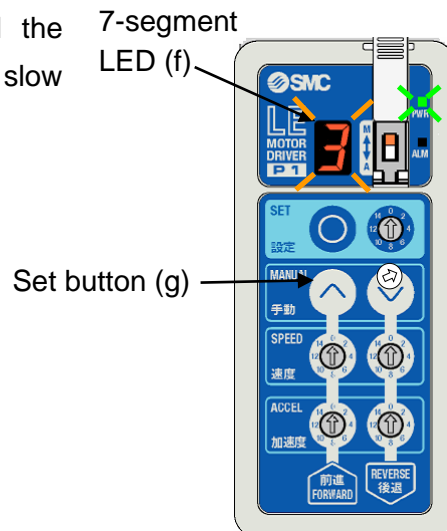

[4] Move the actuator to desired position with external force. Lock in the position by pressing the set button (g).

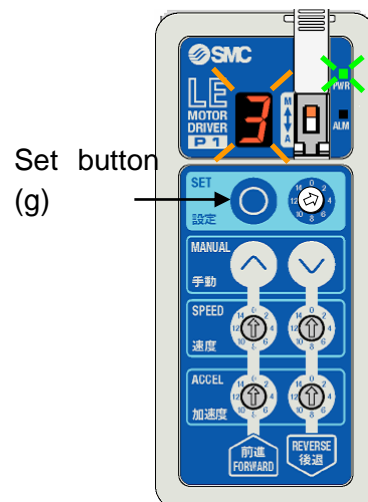

* At this point, the position is not stored. If the power supply is cut, it is necessary to started from procedure [1].

* In case of small lead screws, the actuator may not be moved by external forced even if the servo is off. Perform positioning by (A) jog / inching

[5] Set the operation method of this position by pressing the Forward button (i) or Reverse button (j) while monitoring 7-segment LED (f).

* Actual force of pushing force depends on the actuator. Refer to **10. Initial setting value per actuator** Pushing operation may not be possible depending on the actuator.

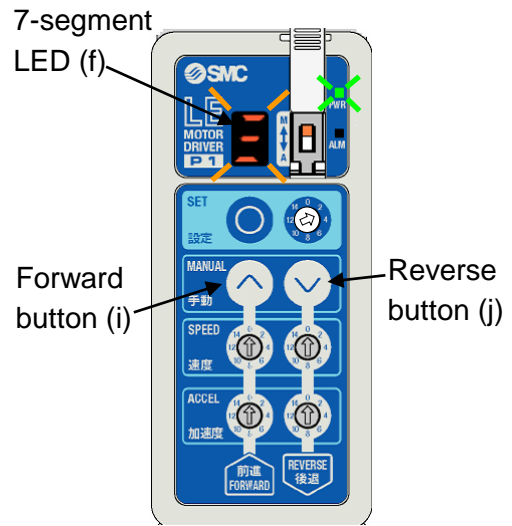

7-segment LED display (Set operation method)

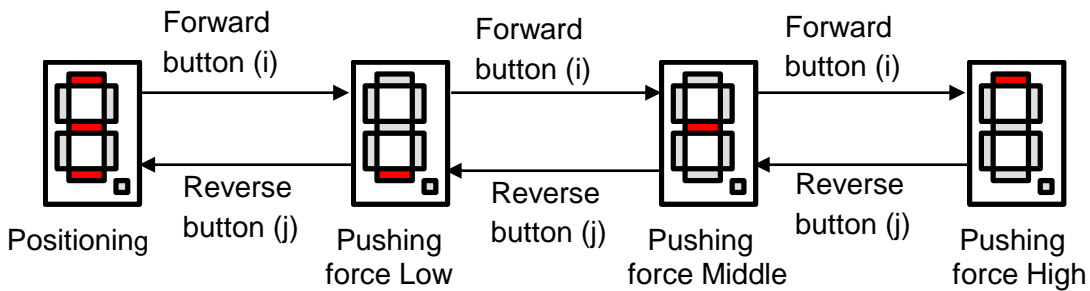

[6] Press set button (g) for 2 seconds to set the operation method. Once this operation is completed, the position and the operation method are stored in the controller, and 7-segment LED (f) display flashes quickly.

That is all for the setting by direct teaching. To set other positions continuously, start from the step [2]. If setting with jog / inching or test run is performed after this setting, press and hold the Forward button (i) and Reverse button (j) for 3 seconds simultaneously to change the power supply LED (a) from a flashing to a solid light.

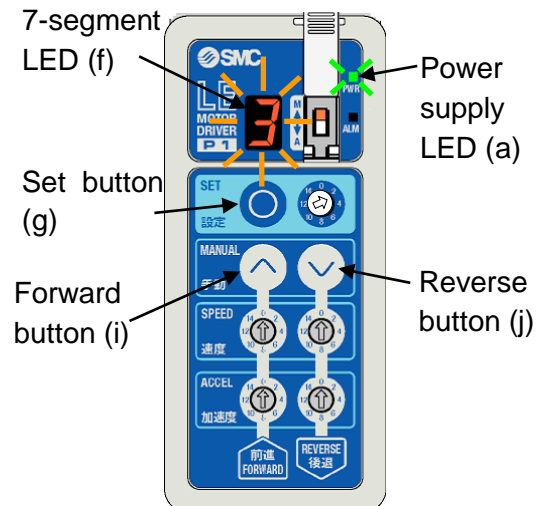

⚠ Caution

- If the return to origin is performed before step [2], an alarm is generated (7-segment LED (f) displays [A], and the alarm LED (b) lights). In this case, reset the alarm by pressing the set button (g), then press and hold the Forward button (i) and Reverse button (j) simultaneously for 3 seconds to change the power supply LED (a) from a flashing to a solid light. Then, set the position switch (h) to "F (15)" and press the set button (g) to perform return to origin before performing the step [1].
- The actuators with a smaller lead, it may not be moved by the external force. Perform positioning by (A) jog / inching in previous page.

(6) Test run

Use the controller buttons and switches to confirm the operating method and position.
Operation method is as follows.

- 1) Set the required position number using the position switch (h).
- 2) Confirm that the position number set is displayed by the 7-segment LED (f) and flashing rapidly.
- 3) Press the set button (g) to start movement. The 7-segment LED (f) flashes slowly during operation. Slow flashing changes to being solid when the set position is reached. This operation confirms the stop position and the operation method.
- 4) Confirm other stop positions with the same operation.

* For Pushing operation, check with the test function of manual mode or auto mode. Refer to **7.4 Test function** for details of test function.

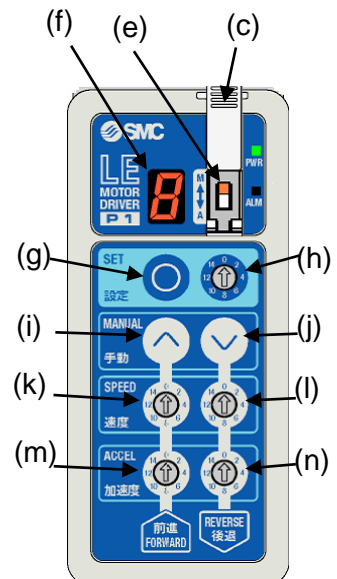

(7) Setting of Speed and Acceleration

One speed and acceleration can be set for each movement direction (back and forth) and it is applied for the operation of all position numbers.

Set the speed and the acceleration by switch (k) to (n) per direction of actuation. The switch can be set in 16 steps. Actual value depends on the actuator. Refer to **10.Initial setting value per actuator**. The operation with the set speed and acceleration can be checked by test run as shown above [(6) Test run].

* Different speeds and accelerations cannot be individually set for positioning of each position number

(8) Completion of setting

After set-up is completed, switch to auto mode using the mode switch (e) and perform operation with PLC. Refer to **9. Operation (Example)** for operation examples with PLC.

Caution

Close the cover (c) after the switching of the mode to avoid unexpected mode change.

7.2 Setting parameters

In manual mode, it is possible to set parameters when necessary.

Example: Change the jog speed level from "1" (default condition) to "3"

- (1) Switch the controller mode switch (e) to manual mode (M).
Example: "4" (Default value of position switch)

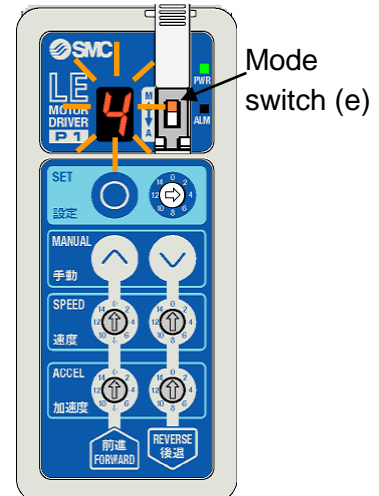

- (2) Press and hold the Forward button (i) and Reverse button (j) simultaneously for 3 seconds so that the power supply LED (a) is changed from a solid light to a flashing.

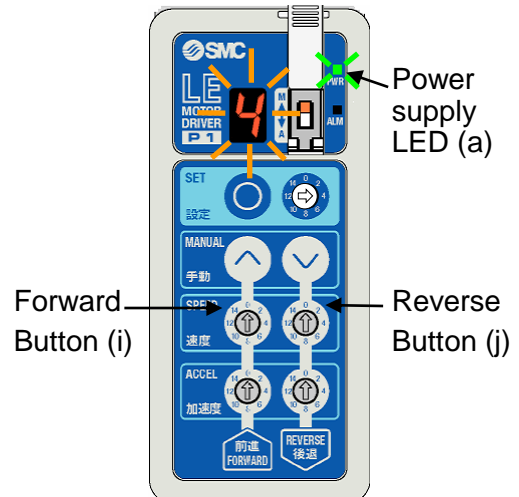

- (3) Set the value of the position switch (h) to "0" and press and hold the set button (g) for 3 seconds. The 7-segment LED (f) displays "0" with a dot and the alarm LED (b) flashes.

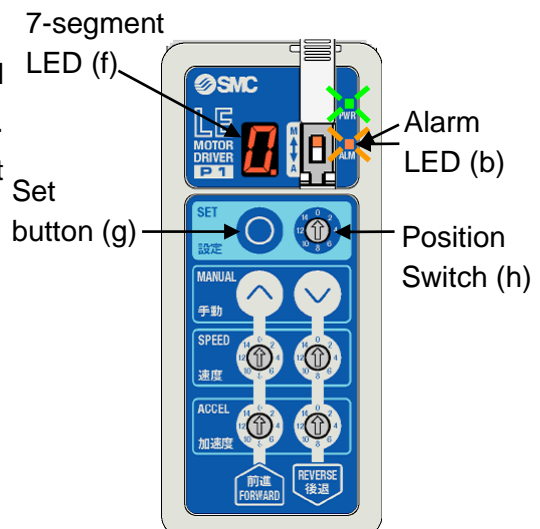

(4) When the position switch (h) is set at the required parameter number ("2" in this case), the 7-segment LED (f) displays the value of the position switch (h) with a dot.

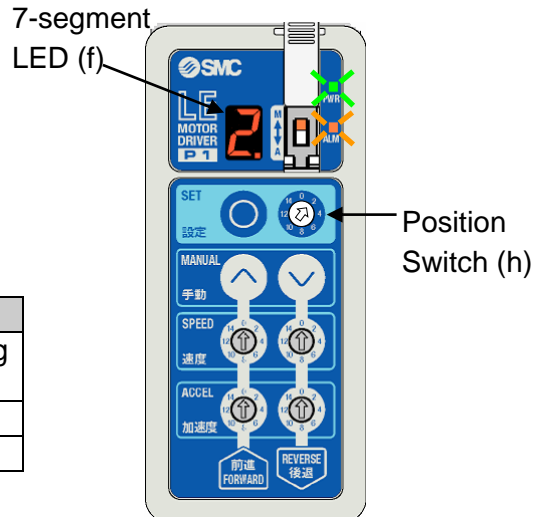

* Refer to the next page for the details of parameters.

NO.	Description	Function
1	Reference for rotating direction	Return to origin or changing forward / reverse
2	Jog speed level	Adjustment of jog speed
3	Inching level	Adjustment of inching

(5) The 7-segment LED (f) indication is turned off by pressing the set button (g), and the current parameter appears. ("1" appears in this example).

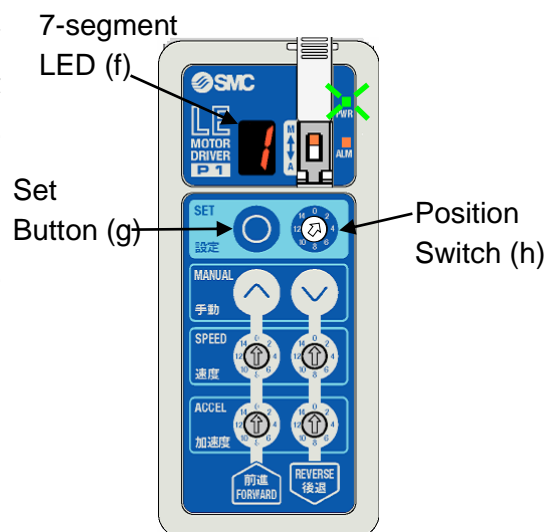

* If the the value of the position switch (h) is changed at this point, it returns to step (4).

(6) To change the parameter value, press and hold the set button (g) for 2 seconds. The 7-segment LED (f) changes to slow flashing.

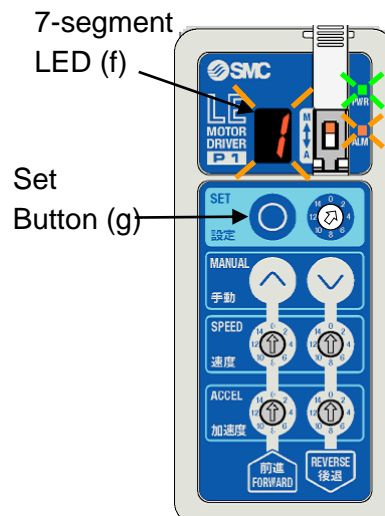

(7) Press forward button (i) and reverse button (j) to adjust the parameter to the desired value ("3" in this example). When the adjustment is completed, press the set button (g) for 2 seconds.

When this setting is completed, the 7-segment LED (f) display changes from slow flashing to a solid light and the set value is stored. However, the changes do not take effect until the power is supplied again.

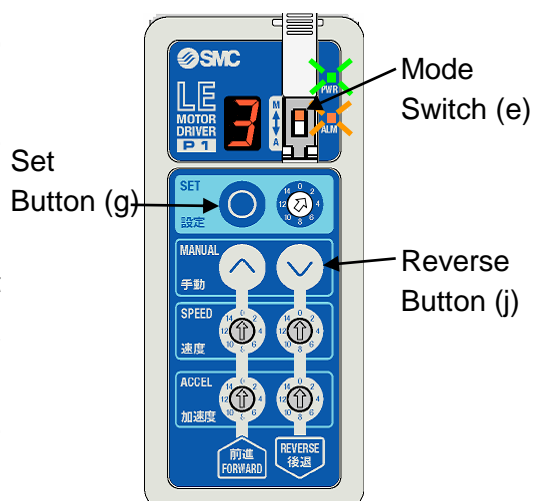

*That is the end for parameter setting. To adjust other parameters continuously, repeat the steps (4) to (7). To perform operation in manual mode after the setting is completed, switch the mode switch (e) to auto mode once, then switch to manual mode.

Description of parameters	Number of parameters	Value and the content of parameters
Reference for rotating direction	1	Change the direction of the return to origin and forward and reverse. (*) 1: CW 2: CCW
Jog speed level	2	Adjust the jog speed 1: Multiplier=1 (Default value at the time of shipment) 2: Multiplier=2 3: Multiplier=4 4: Multiplier=8 Jog speed = (Reference value per actuator) × (Multiplier)
Inching level	3	Adjust the inching amount 1: Multiplier=1 (Default value at the time of shipment) 2: Multiplier=2 3: Multiplier=4 4: Multiplier=8 Inching level = (Reference value per actuator) × (Multiplier)

(*) The default value varies depending on the actuator.
Please refer to the manual of the actuator for more details.

! Caution

- Parameter changes take effect after turning off the power supply and turning it on again.
- For the default value of the return to origin and the reference value of jog speed and the inching amount, refer to **10. Initial setting value per actuator.**
- When the reference for rotating direction is changed, the direction of forward and reverse is switched, and the speed and acceleration per direction are changed as well. Therefore, it is necessary to set the position, speed and acceleration again.

7.3 Controller modes

Controller modes are divided into two types, auto mode and manual mode. There are several status types in one mode. The figure below shows how the status changes.

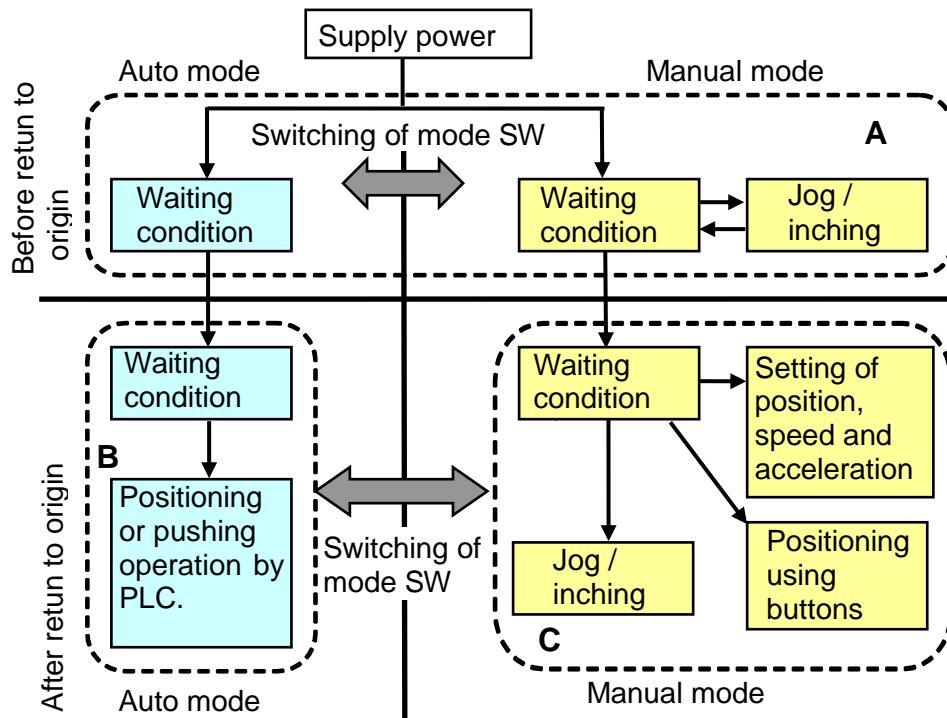

Followings are the explanation of (A), (B), and (C) circled with dashed line.

- (A) Before return to origin
- (B) Auto mode after return to origin
- (C) Manual mode after return to origin

! Caution

- Signal is not output from I/O right after switching from manual mode to auto mode. Output from I/O is made after the next input of operation command.
- Output from I/O is not made if switching from auto mode to manual mode. (Except test function)

(A) Before return to origin

The transition of the status before return to origin is shown below. After turning on the power supply, the controller status is in waiting mode which is set by mode switch (e). The operation of jog / inching at manual mode is available before returning to origin.

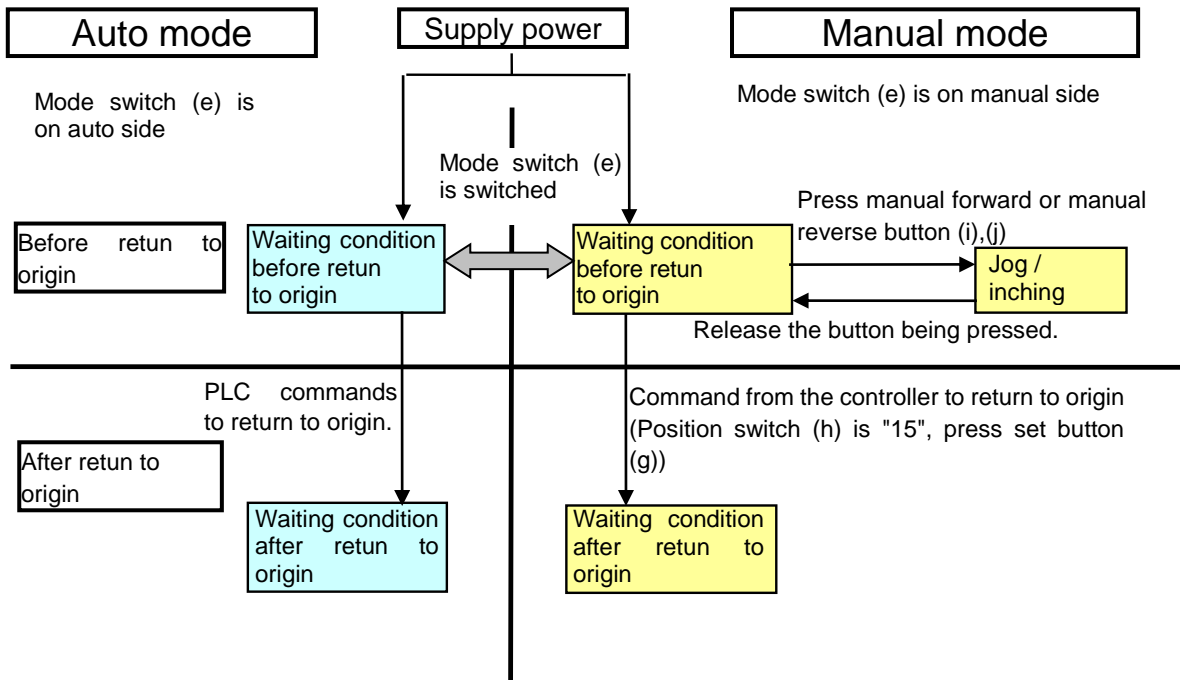

Refer to [8.1 Return to origin](#) for details.

Refer to [8.4 Jog / inching operation](#) for details.

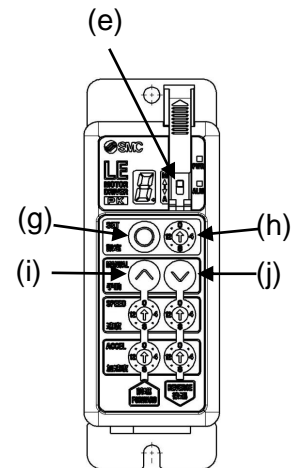

(B) Auto mode after return to origin

The status of the auto mode after return to origin is shown below. At auto mode, only the operation command from I/O such as PLC is accepted. Basically, position, operation method, speed and acceleration cannot be adjusted in auto mode.

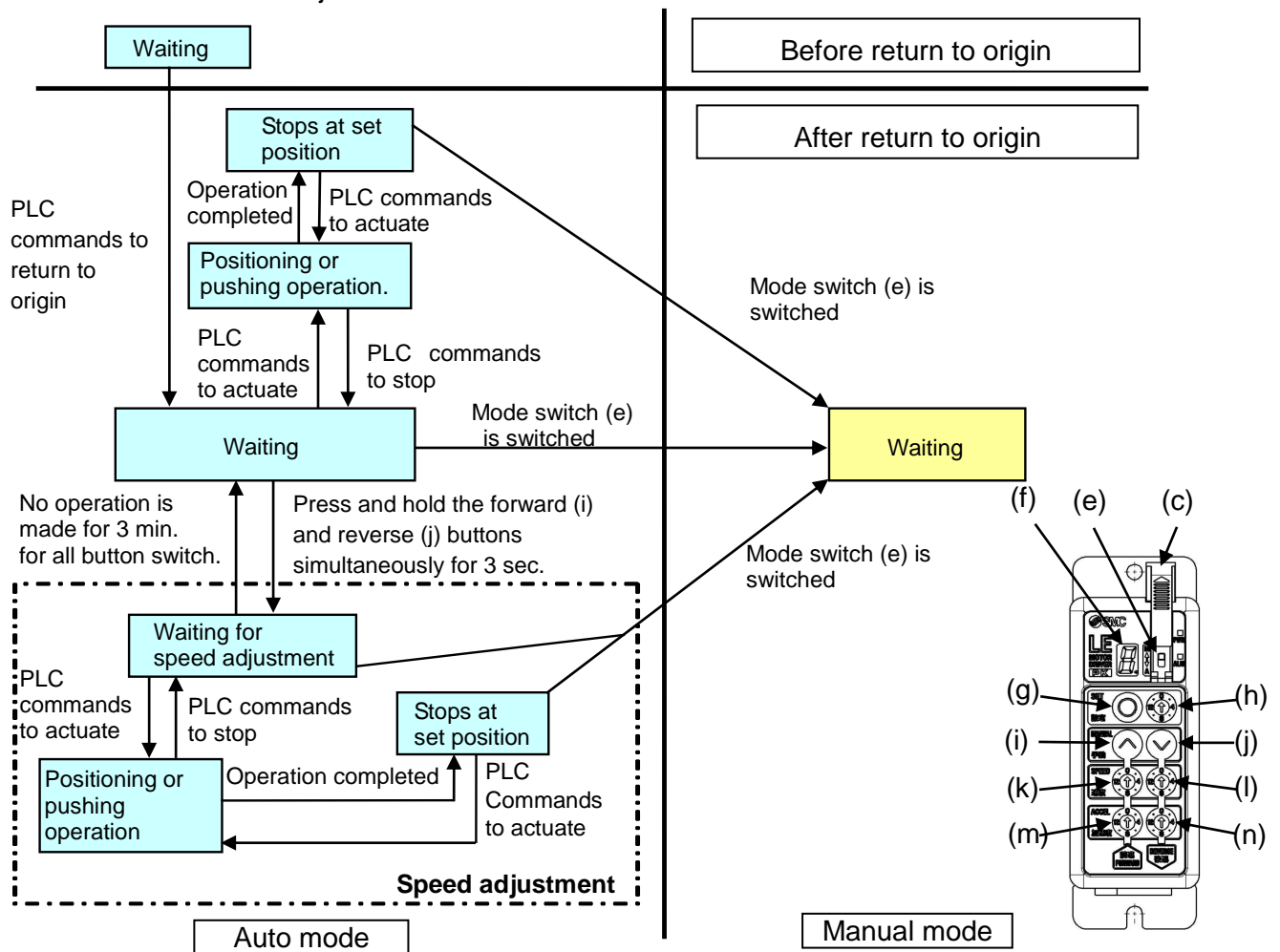

Auto mode is presupposed operation by I/O from PLC. When the buttons and switches other than set button (g) for releasing the alarm are operated, the 7-segment LED (f) indicates "L".

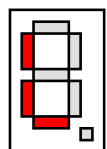

L display

When the status is moved to speed adjustment, following items are become different from normal operation.

- (1) More dots of 7-segment LED (f) indication than normal operation.
- (2) Speed and acceleration adjustment become available temporarily.
- (3) When no operation is made for 3 minutes for any buttons or switches, operation returns to normal mode.

⚠ Caution

- In auto mode, changing the speed, acceleration switch values which are set by (k) to (n) do not take effect except during the speed adjustment status. If returning to auto mode after changing to manual mode, the value of the switch affects the operation.
- Close the cover(c) after the switching of the mode to avoid unexpected mode change.

(C) Manual mode after return to origin

The status of the manual mode after return to origin is shown below. In manual mode, return to origin is controlled by the operation of the controller buttons and switches. The speed and acceleration can be adjusted any time. It is also possible to set the position and operation method. Pushing operation is available only with test function.

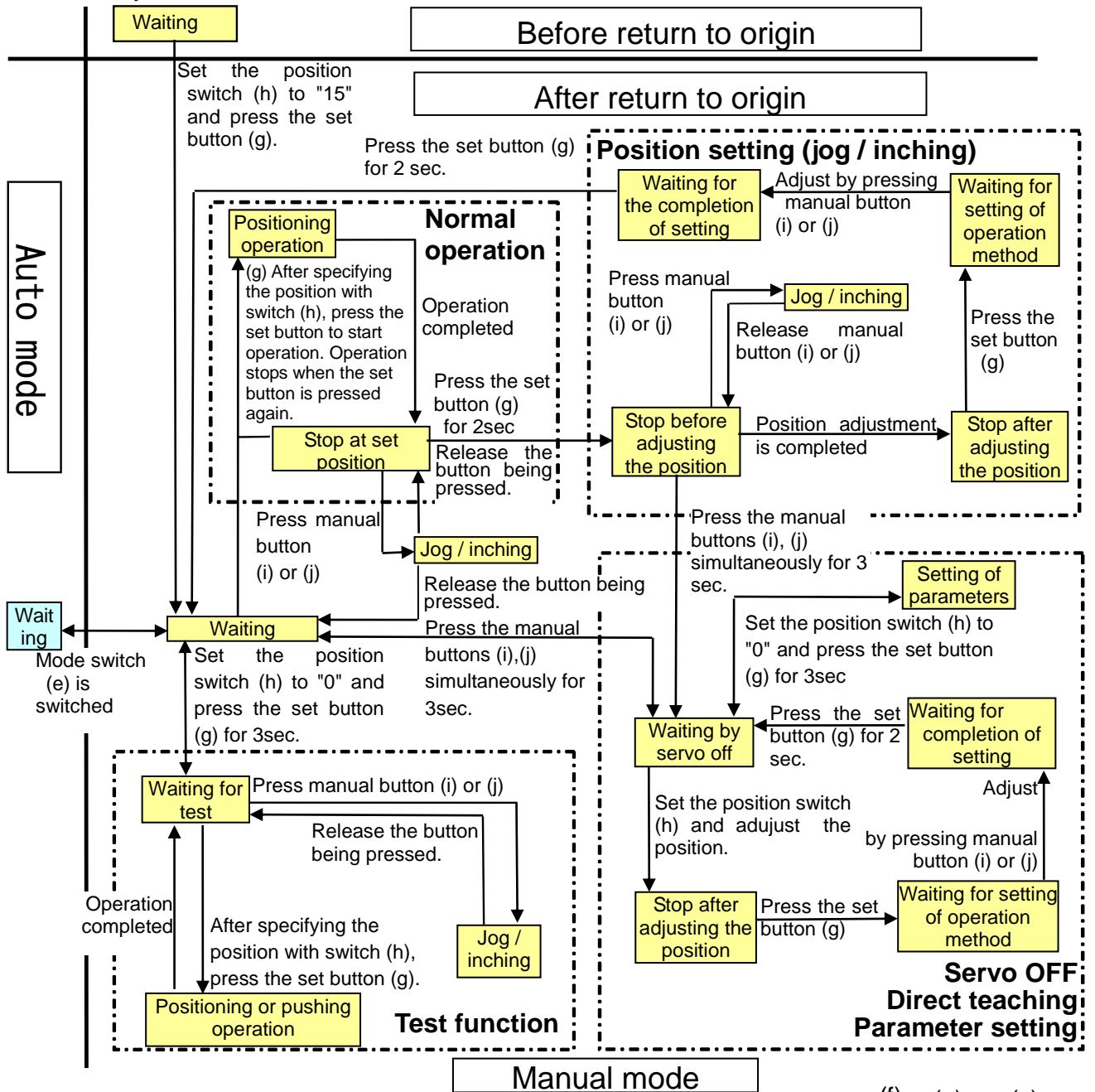

Refer to **7.4 Test function** for details of normal operation and test function.

Refer to **8.5 Servo ON** for turning off of servo.

Refer to **7.2 Setting parameters** for parameter setting.

Refer to **8.4 Jog / inching operation** for jog and inching.

⚠ Caution

Close the cover (c) after the switching of the mode to avoid unexpected mode change.

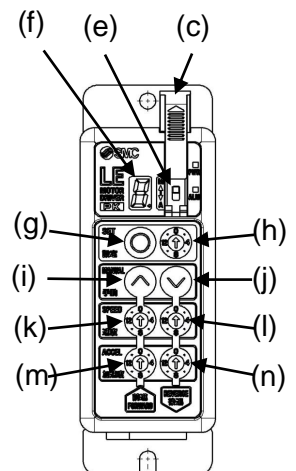

7.4 Test function

The table below shows the difference between normal operation and test function in manual mode. To start the test function, set the position switch (h) to "0" while the power LED (a) is on (= servo ON) in manual mode and the actuator stops, and press the set button (g) for 3 seconds. When test function starts, the dot on the lower right of the 7-segment LED (f) will light up.

	Normal operation	Test function
Availability of pushing operation	X	O
Operation by parallel I/O input	X	X
Output to parallel I/O	X	O
7-segment LED (f) display	Without dot Target position setting: Quick flashing During operation: Slow flashing Reached the target position: Lights up	With dot Target position setting: Quick flashing During operation: Slow flashing Reached the target position: Lights up
Adjustment of the speed / acceleration	O	O
Operation method using buttons	Press the set button (g) to start operation. Operation stops when the set button is pressed again.	Moves towards the target position when the set button (g) is pressed. (Not necessary to keep pressing the button)

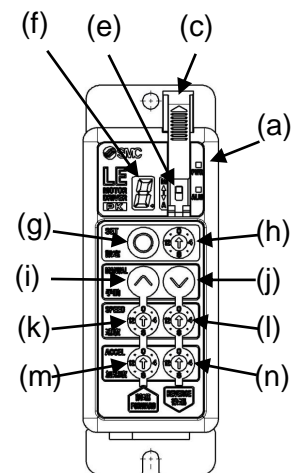

8. Operations

8.1 Return to origin

After supplying power, it is necessary to perform return to origin first to perform positioning or pushing with the actuator. (To ensure the position of origin)

■ Input of return to origin

There are 2 ways for return to origin per mode:

Manual mode: Set the position switch (h) at "15" and press the set button (g).

Auto mode: Turn on I/O IN0 to IN3 simultaneously.

■ Return to origin

The actuator travels to the origin position from the initial position when the power was supplied. (Origin position depends on the actuator). Refer to (1) in the figure below.

The controller recognizes the actuator end when the slider travels to the actuator end and stops for specific time. Then, the actuator travels to the opposite to the origin with low speed. See (2) in the figure below.

The position after the travel is specified as an origin.

Return to origin input → Travels to the origin direction
→ Stop traveling → Reverse → Origin position

(e.g.) Return to origin

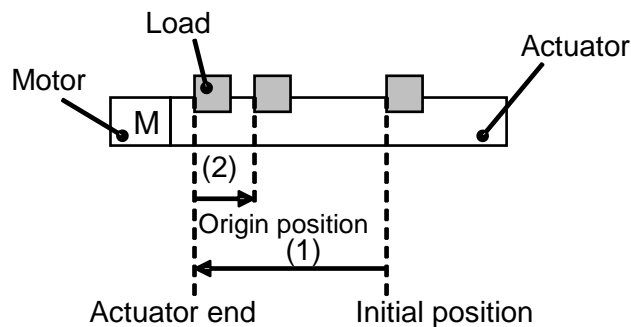

⚠ Caution

The direction of return to home depends on the actuator. Refer to **10. Initial setting value per actuator** for the default setting of the return to origin direction.

8.2 Positioning

The actuator travels to the target position at speed and acceleration which are set per operating direction.

When the actuator reaches the target position, an operation complete signal (OUT0 to OUT3) is output.

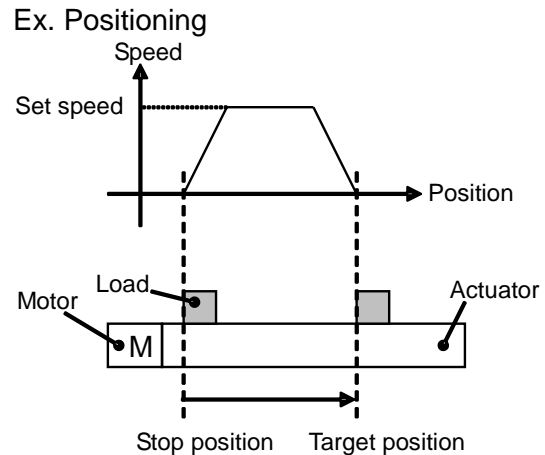

*The speed wave in the chart above is simplified.

8.3 Pushing operation

Perform pushing operation after performing the positioning operation at the set speed and acceleration. At pushing operation, the actuator travels at slow pushing speed from the operation starting position to the opposite side actuator end with less than the set pushing thrust force.

⚠ Caution

- At manual mode, positioning is performed even if pushing is set. (Except during test function)
- Pushing operation may not be possible depending on the actuator. Refer to **10.Initial setting value per actuator.**

(1) Successful pushing operation

At pushing operation, operation complete signal is output when the pushing thrust force is kept at more than the set value for a specific period of time. However, the set thrust force continues to be generated even when the pushing operation is completed.

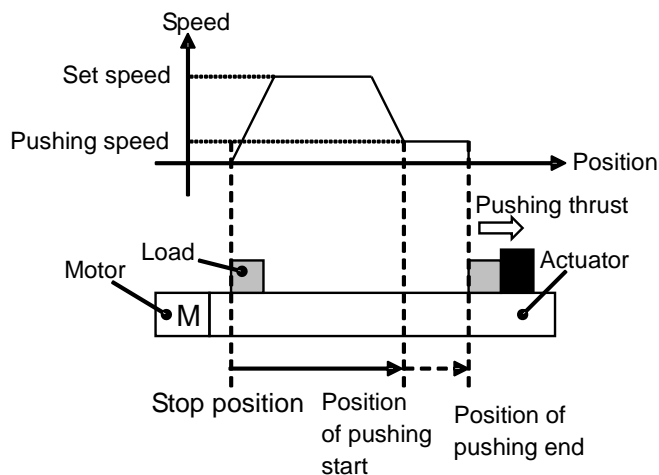

* The velocity wave form in the chart on the left is simplified.

(2) Unsuccessful pushing operation (Idling)

If pushing is not completed even when the actuator travels from the pushing start position to the actuator end, it is pushed at the actuator end and the operation complete signal is output.

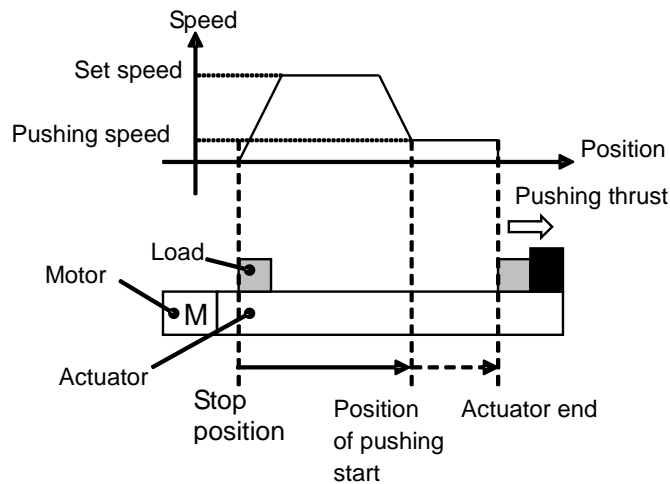

* The velocity waveform in the chart on the left is simplified.

(3) Movement of workpiece after the completion of the pushing process

- (i) The workpiece moves in the pushing direction.

When the reaction force of the pushed object becomes small after the completion of pushing and the actuator is moved by the thrust force smaller than the set pushing thrust force, the completion signal is not output, and the actuator will continue to move within the range up to the actuator end. Operation complete signal is output when the pushing thrust force is kept at larger than the set value for a specific period.

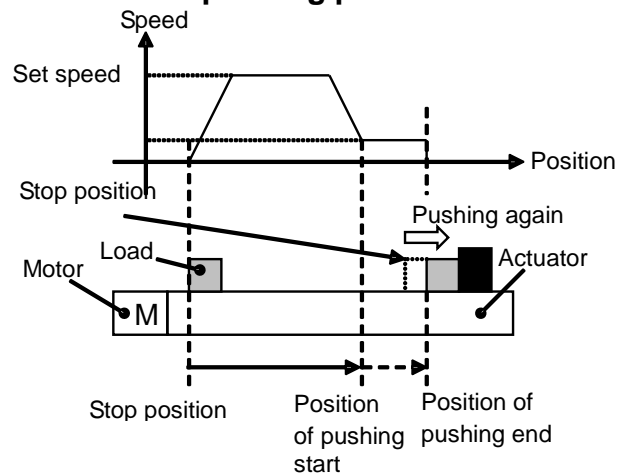

※The velocity wave form in the chart above is simplified.

- (ii) The workpiece moves toward the opposite of the pushing direction (The reaction force of the workpiece is too large and the actuator is pushed back)

When the actuator is pushed back after the pushing operation is completed the actuator is pushed until the reaction force and pushing force are balanced in the direction that the pushing started. (Completion signal stays ON) An alarm (Pushing failure) is generated when the actuator is pushed back farther than the start position of pushing.

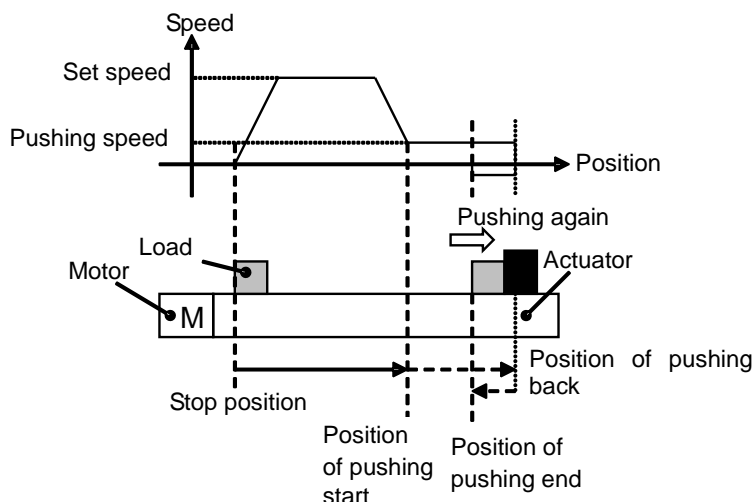

* The velocity waveform in the chart on the left is simplified.

8.4 Jog / inching operation

Jog / inching is available by pressing forward button (i) or reverse button (j) at manual mode. Jog / inching can be performed before return to origin.

Operation method

Inching starts and stops by pressing forward button (i) or reverse button (j). When the button is pressed continuously for 1 second or longer after inching is completed, the jog operation starts. Jog operation stops when the button is released.

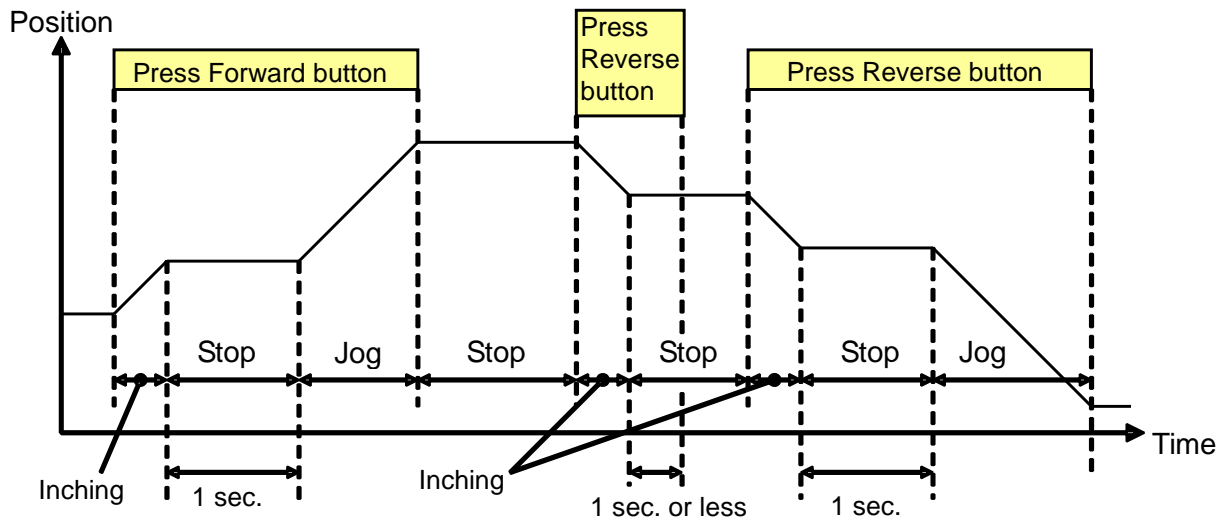

⚠ Caution

- The travel amount of inching and jog speed depend on actuators. Refer to **10.Initial setting value per actuator.**
- The travel amount of inching and jog speed can be changed. Refer to **7.2 Setting parameters** for details.

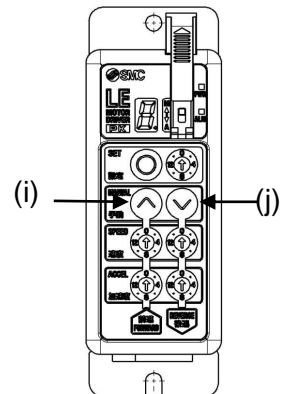

8.5 Servo ON

Servo ON signal is not assigned to the parallel I/O of this controller. The power supply LED (a) changes from a flashing light to a solid light after a specific period of time after power supply and the servo turns on. (*)

The table below shows conditions for servo OFF

	Conditions for servo OFF	Indication of servo OFF
Manual mode	Alarm is generated, or servo OFF by pressing Forward button (i) and Reverse button (j) simultaneously for 3 seconds.	Power supply LED (a): Flashing Alarm: OFF
Auto mode	Alarm is generated, or servo OFF by inputting I/O STOP signal.	Power supply LED (a): Flashing

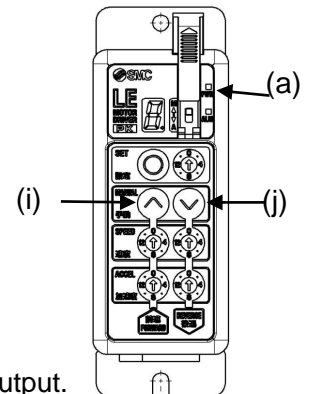

(*) It may take about ten seconds from the power supply turning on to the ALARM output.

8.6 Response time for the controller input signal

Response delay due to the controller input signal contains following factors.

- (1) Controller input signal scan delay
- (2) Delay due to input signal analysis
- (3) Delay of command analysis

Leave an interval of a minimum of 15 ms (recommendation is 30 ms) between input signals and maintain the state of the signal for a minimum of 15ms (recommendation is 30 ms), because PLC processing delays and controller scanning delays can occur. Time the input signal conditions according to the response output signals.

When one command is made by inputting several I/O simultaneously, the time difference between signals has to be 3 ms or less. If the time difference is longer than 3 ms, it is recognized as another signal and starts the operation. For example, when IN0 and IN1 are commanded to turn ON (position number 3) simultaneously and the time difference between them is large, only the first command is recognized (Only IN0 input is recognized in the following example).

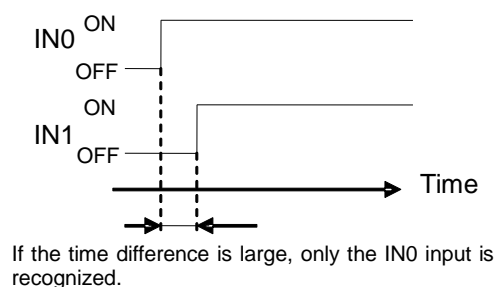

8.7 LED display in auto mode

The 7-segment LED (f) in auto mode displays position number during operation (or operation completion) and alarm group when alarm is generated (ALM LED lights up).

7-segment LED (f) display	ALM LED (b) (Red)	PWR LED (a) (Green)	Controller status
"-" (Solid light)	OFF	Flashing / Solid light *1	Right after supplying power
"F" (Flashing)	OFF	ON	Under return to origin *4
"F" (Solid light)	OFF	ON	Return to origin completed
Position numbers "1" to "9", "A" to "E" (Flashing)	OFF	ON	Under operation *4
Position numbers "1" to "9", "A" to "E" (Solid light)	OFF	ON	Operation completed
Alarm group "A" to "E" (Solid light)	ON	Flashing / Solid light *2	Alarm generated
"L" (Flashing) *3	ON	Flashing / Solid light	Buttons and switches operated

*1 It is changed from a flashing to a solid light after servo is turned on. (Refer to 8.5 Servo ON for details.)

*2 The servo is turned off depending on the alarm contents. If so, the LED is changed from a solid light to a flashing light.

*3 This indicates that the operation of the forward / reverse buttons and speed / acceleration switches are disable (locked). The operating conditions or servo ON / OFF are not influenced.

When alarm is being generated, it displays the alarm group ("L" is not displayed).

- When the set button (g), forward button (i), or reverse button (j) is operated, "L" will be displayed for 3 seconds before returning to the display of before operating those buttons.
- If the speed or acceleration switches (k) to (n) have been changed, the display is not returned unless change the switch value to the value before changing the switches or switch to manual mode and store the changed switch value to the controller. ("L" will continue to be displayed even when power is supplied again.)

*4 If RESET or STOP is turned ON; or M24V is disconnected during return to origin or operation, the operation will stop and 7-segment LED will be changed from a flashing to a solid light.

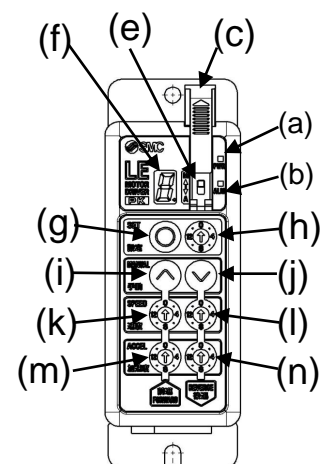

9. Operation (Example)

9.1 Positioning / Return to origin

e.g.) If the operation pattern is Return to origin --> Position No. 1 --> Position No. 2 --> Position No. 1:

Forward: Speed 5, acceleration 3 (Switch value)

Reverse: Speed 9, acceleration 7 (Switch value)

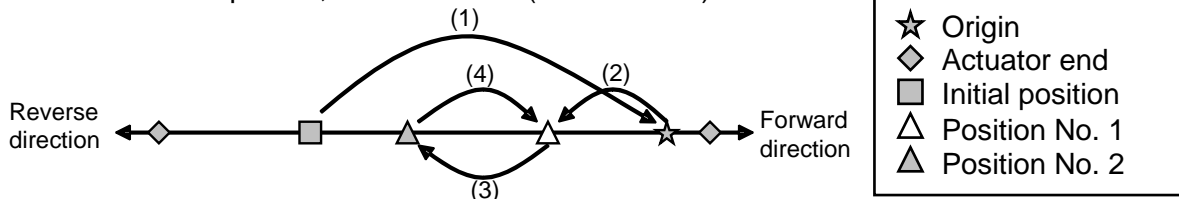

	Start position	End position	Operating direction	speed	acceleration	Operation method
(1)	Undecided	Origin position	Forward	Fixed	Fixed	Return to origin
(2)	Origin position	No. 1	Reverse	9	7	Positioning
(3)	No. 1	No. 2	Reverse	9	7	Positioning
(4)	No. 2	No. 1	Forward	5	3	Positioning

* Even for the same position number 1, the travel speed and the acceleration may vary due to the operating direction.

e.g.) I/O timing chart when the actuator is operated by PLC.

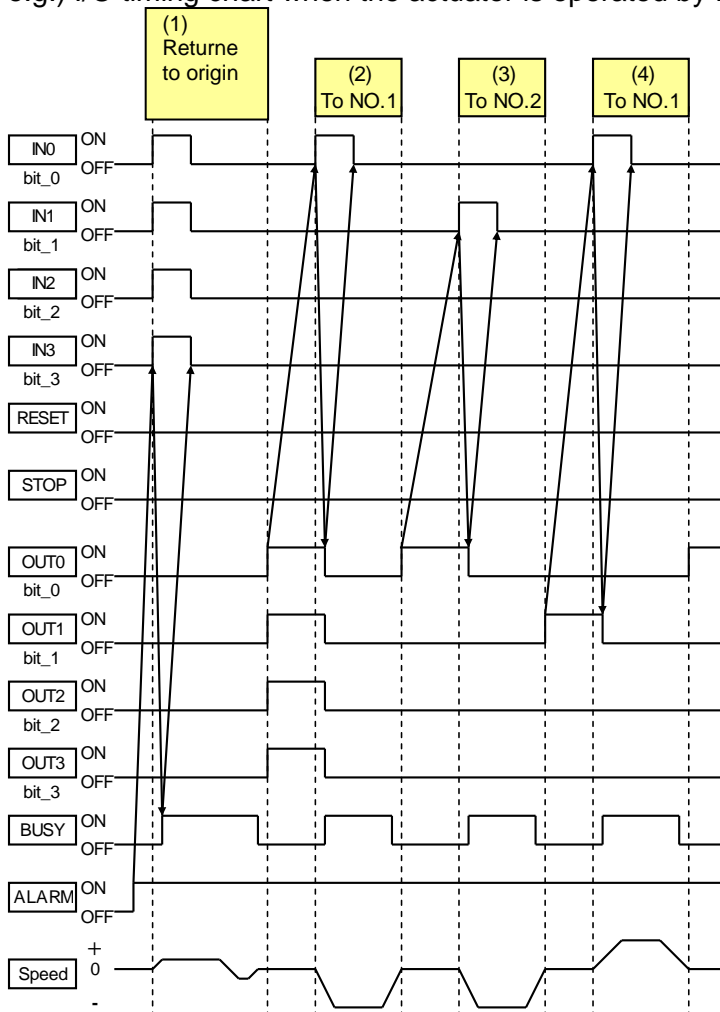

<Procedure>

- [1] After supplying power, servo is turned on. Then, ALARM is turned on.
- [2] After confirming that the ALARM is turned on, turn on IN0 to 3 to perform (1) Return to origin.
- [3] When return to origin starts, BUSY is turned on.
- [4] After confirming that BUSY is turned on, turn off IN0 to IN3.
- [5] When return to origin is completed, BUSY is turned off and OUT0 to OUT3 are turned on.
- [6] After confirming that OUT0 to OUT3 are turned on, turn on IN0 to start (2) travel to the position No. 1.
- [7] When the operation starts, BUSY is turned on and OUT0 to OUT3 are turned off.
- [8] After confirming that BUSY is turned on, turn off IN0.
- [9] When the operation is completed, BUSY is turned off and OUT0 is turned on.
- [10] Do the same for the travel to the position No. 2 and No. 1.

9.2 Pushing operation

e.g.) If the operation pattern is Position No. 3 --> Position No. 4 --> Position No. 3 --> Position No. 5:

Forward: Speed 5, acceleration 3 (Switch value)

Reverse: Speed 9, acceleration 7 (Switch value)

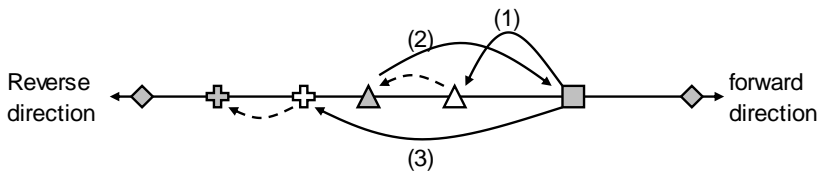

- ◇ Actuator end
- Position No. 3
- △ Position No. 4
- △ Position at which pushing to the reverse direction from position No. 4 is completed
- ⊕ Position No. 5
- ⊕ Position at which pushing to the reverse direction from position No. 5 is completed

	Start position	End position	Operating direction	speed	acceleration	Operation method
(1)	No. 3	No. 4	Reverse	9	7	Pushing
(2)	No. 4	No. 3	Forward	5	3	Positioning
(3)	No. 3	No. 5	Reverse	9	7	Pushing

e.g.) I/O timing chart when the actuator is operated by PLC

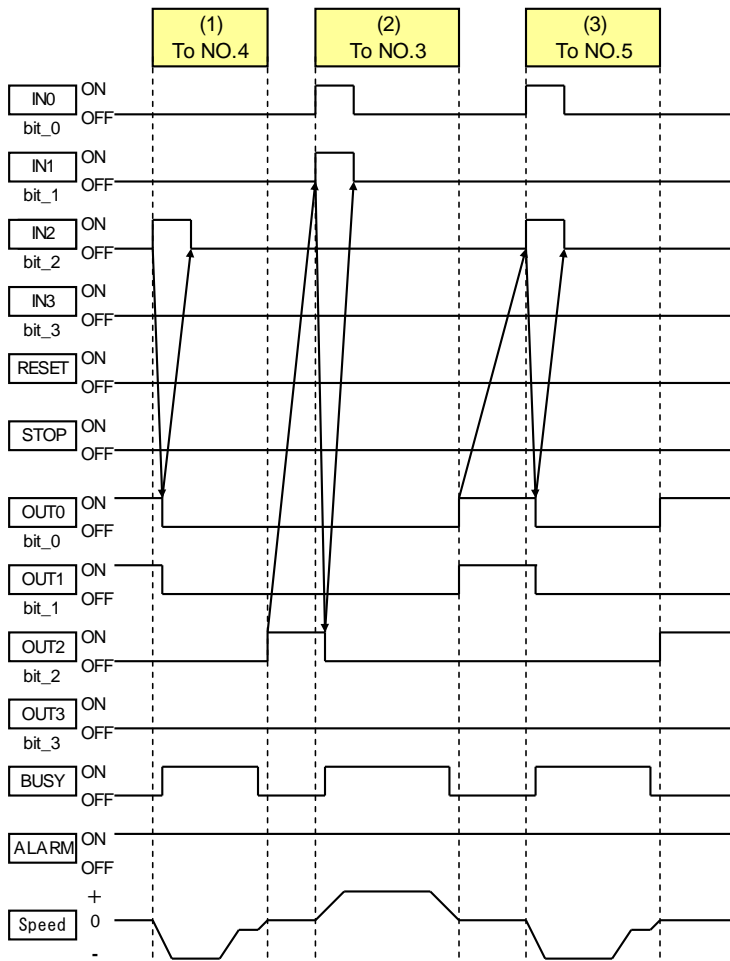

<Procedure>

- [1] After confirming that OUT0 and OUT1 are turned on, turn on IN2 to start (1) travel to the position No. 4.
- [2] When the operation starts, BUSY is turned on and OUT0 and OUT1 are turned off.
- [3] After confirming that BUSY is turned on, turn off IN2.
- [4] When the operation is completed, BUSY is turned off and OUT2 is turned on.
- [5] Do the same for the travel to the position No. 3 and No. 5.

9.3 Stoppage during operation

e.g.) Position No. 6 -> Stop by inputting the RESET signal while the actuator is traveling to position No. 7
 7 -> Position No. 8 -> Stop by inputting the STOP signal while the actuator is traveling to position No. 7 -> Position No. 9

Forward: Speed 5, acceleration 3 (Switch value)
 Reverse: Speed 9, acceleration 7 (Switch value)

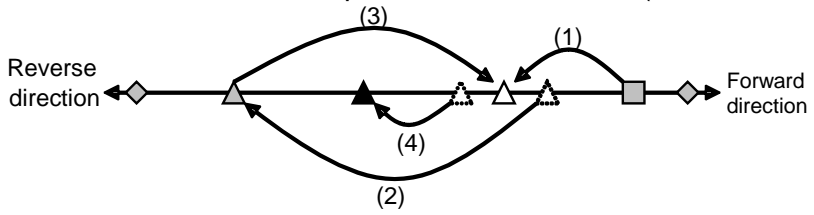

	Start position	End position	Operating direction	speed	acceleration	Operation method
(1)	No. 6	No. 7	Reverse	9	7	Positioning
(2)	-	No. 8	Reverse	9	7	Positioning
(3)	No. 8	No. 7	Forward	5	3	Positioning
(4)	No. 7	No. 9	Reverse	9	7	Positioning

* Even for the same position number 1, the travel speed and the acceleration may vary due to the operating direction.

e.g.) I/O timing chart when the actuator is operated by PLC.

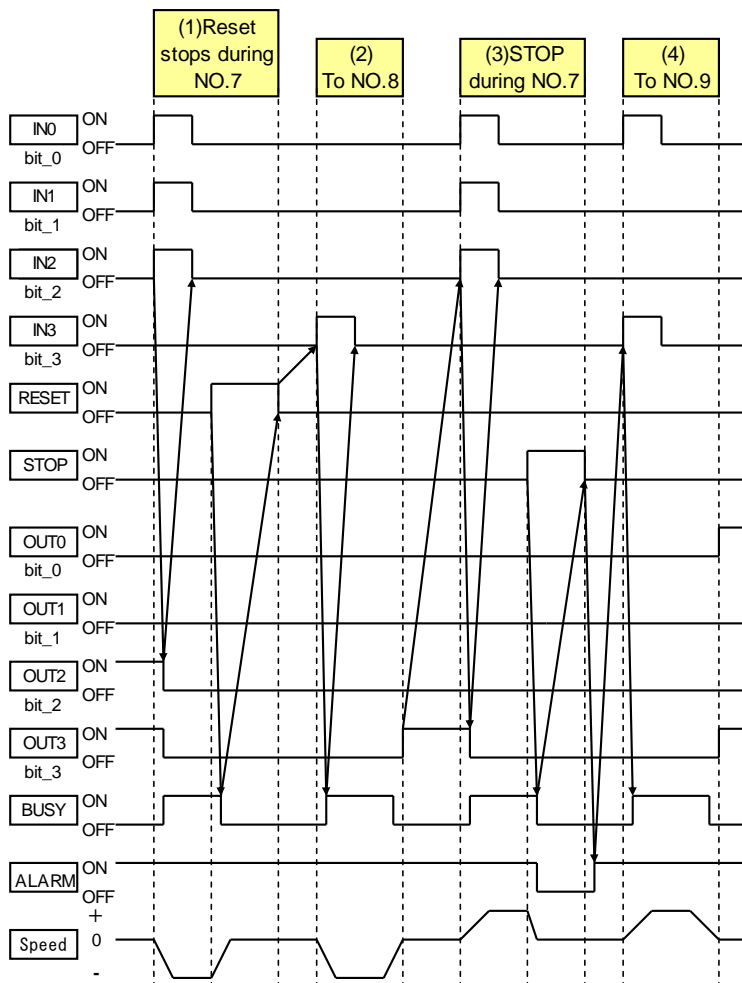

<Procedure>

- [1] After confirming that OUT2 and OUT3 are turned on, turn on IN0 to IN2 to start (1) travel to the position No. 7.
- [2] When the operation starts, BUSY is turned on and OUT0 and OUT1 are turned off.
- [3] After confirming that BUSY is turned on, turn off IN2.
- [4] Input RESET during operation.
- [5] The operation stops by reducing speed, and BUSY is turned off.
- [6] After confirming that BUSY is turned off, turn off RESET.
- [7] Turn on IN3 to start (2) travel to the position No. 8.
- [8] When the operation starts, BUSY is turned on.
- [9] After confirming that BUSY is turned on, turn off IN3.
- [10] When the operation is completed, BUSY is turned off and OUT3 is turned on.
- [11] After confirming that OUT3 is turned on, turn on IN0 to IN2 to start (3) travel to the position No. 7.
- [12] When the operation starts, BUSY is turned on and OUT3 is turned off.
- [13] Input STOP during operation.
- [14] The operation stops by reducing speed, and Servo is turned off. BUSY and ALARM are turned off.
- [15] After confirming that BUSY and ALARM are turned off, turn off STOP.
- [16] Turn on Servo to turn on ALARM.
- [17] After confirming that ALARM is turned on, turn on IN0 and IN3 to start travel to the position No. 9. (The rest is omitted.)

9.4 Alarm generation and reset

e.g.) Position No. 10→Alarm generated during the travel to Position No. 11→Take countermeasures to reset the alarm→Travels to position No. 11→Travels to Position No. 10

Forward: Speed 5, acceleration 3 (Switch value)

Reverse: Speed 9, acceleration 7 (Switch value)

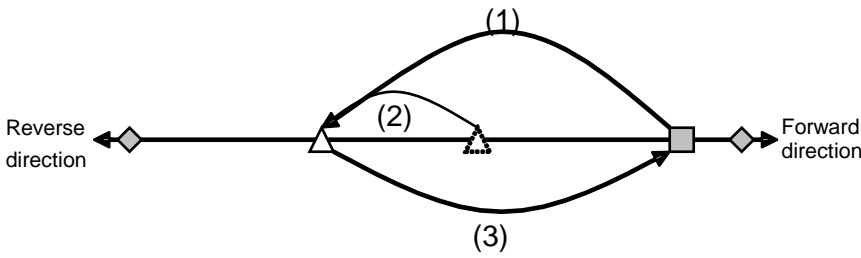

	Start position	End position	Operating direction	speed	acceleration	Operation method
(1)	No. 10	No. 11	Reverse	9	7	Positioning
(2)	-	No. 11	Reverse	9	7	Positioning
(3)	No. 11	No. 10	Forward	5	3	Positioning

e.g.) I/O timing chart when the actuator is operated by PLC.

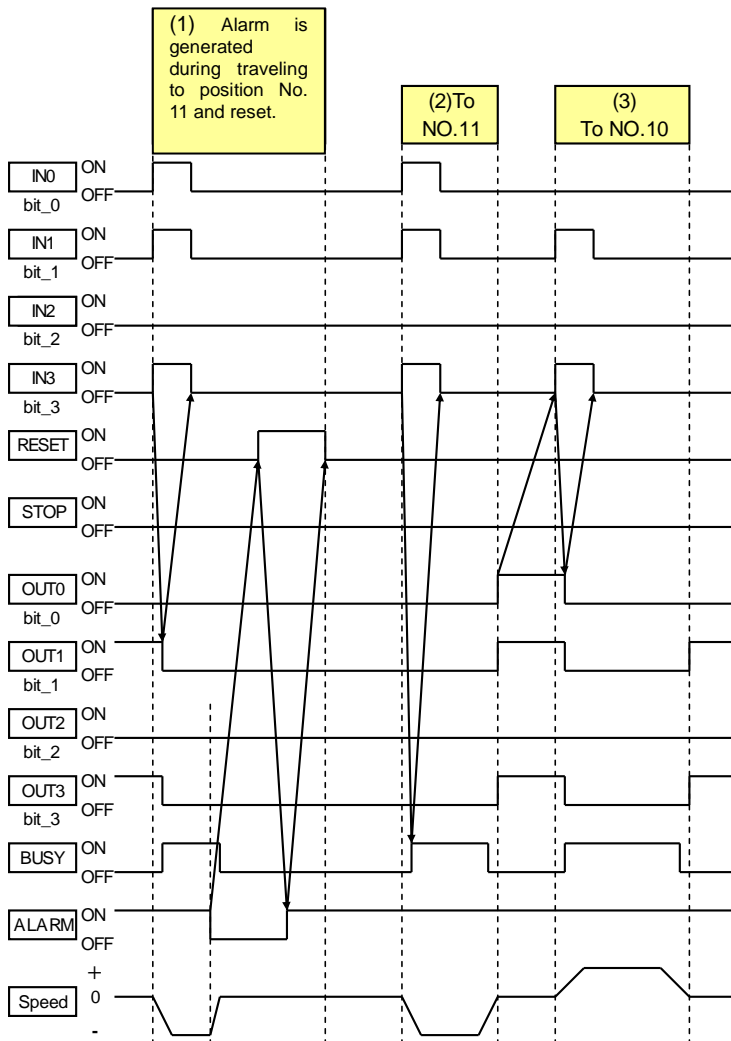

<Procedure>

- [1] After confirming that OUT1 and OUT3 are turned on, turn on IN0, IN1 and IN3 to start (1) travel to the position No. 11.
- [2] When the operation starts, BUSY is turned on and OUT1 and OUT3 are turned off.
- [3] After confirming that BUSY is turned on, turn off IN0, IN1 and IN3.
- [4] Alarm is generated during the operation, and ALARM and BUSY are turned OFF, then the operation stops.
- [5] Resolve the cause of the alarm and turn on RESET.
- [6] Alarm is reset. ALARM is turned OFF.
- [7] After confirming that ALARM is turned off, turn off RESET.
- [8] Turn on IN0, IN1 and IN3. Then, start the (2) travel to the position No. 11 again.
- [9] When the operation starts, BUSY is turned on.
- [10] After confirming that BUSY is turned on, turn off IN0, IN1 and IN3.
- [11] When the operation is completed, BUSY is turned off and OUT0, OUT1 and OUT3 are turned on.
- [12] After confirming that OUT0, OUT1 and OUT3 are turned on, turn on IN1 and IN3 to start travel to the position No. 10.
- [13] When the operation starts, BUSY is turned on and OUT0, OUT1 and OUT3 are turned off.
- [14] After confirming that BUSY is turned on, turn off IN1 and IN3.
- [15] When the operation is completed, BUSY is turned off and OUT1 and OUT3 are turned on.

10. Initial setting value per actuator

10.1 Initial setting value of LEF series

Initial setting values of the LEF series are shown below.

Refer to the table below for the initial setting of the Return to origin, jog and inching.

		LEFB	LEFS				
		16, 25, 32 common	16A	16B	25H	25A	25B
Return to origin	Direction	Motor side					
	Speed [mm/s]	60	30				
	Acceleration [mm/s ²]	1000					
Jog	Speed [mm/s]	48	10	5	20	12	6
	Acceleration [mm/s ²]	1000					
Inching	Travel distance [mm]	5	1				

		LEFS					
		32H	32A	32B	40H	40A	40B
Return to origin	Direction	Side of the motor					
	Speed [mm/s]	30					
	Acceleration [mm/s ²]	1000					
Jog	Speed [mm/s]	24	16	8	30	20	10
	Acceleration [mm/s ²]	1000					
Inching	Travel distance [mm]	1					

Pushing is not available for LEF series. Even if pushing is set on the the 7-segment LED (f) of the controller, it becomes positioning.

Refer to the table below for the speed and the acceleration of the LEFB series.

	LEFB16		LEFB25		LEFB32	
	Speed [mm/s]	Acceleration [mm/s ²]	Speed [mm/s]	Acceleration [mm/s ²]	Speed [mm/s]	Acceleration [mm/s ²]
0	48	200	48	200	48	200
1	60	300	60	300	60	300
2	70	400	70	400	70	400
3	80	500	80	500	80	500
4	100	600	100	600	100	600
5	150	700	200	700	200	700
6	200	800	300	800	300	800
7	300	900	400	900	400	900
8	400	1000	500	1000	500	1000
9	500	1200	600	1200	600	1200
10	600	1400	700	1400	700	1400
11	700	1600	800	1600	800	1600
12	800	1800	900	1800	900	1800
13	900	2000	1000	2000	1000	2000
14	1000	2500	1200	2500	1200	2500
15	1100	3000	1400	3000	1500	3000

Refer to the table below for the speed and the acceleration of the LEFS series.

	LEFS16A		LEFS16B		LEFS25H		LEFS25A		LEFS25B	
	speed [mm/s]	accelera tion [mm/s ²]	speed [mm/s]	accelera tion [mm/s ²]	speed [mm/s]	accelera tion [mm/s ²]	speed [mm/s]	accelera tion [mm/s ²]	speed [mm/s]	accelera tion [mm/s ²]
0	10	200	5	200	20	200	12	200	6	200
1	20	300	10	300	30	300	20	300	10	300
2	30	400	15	400	40	400	30	400	15	400
3	40	500	20	500	50	500	40	500	20	500
4	50	600	25	600	60	600	50	600	25	600
5	60	700	30	700	80	700	60	700	30	700
6	80	800	40	800	100	800	80	800	40	800
7	100	900	50	900	200	900	100	900	50	900
8	150	1000	75	1000	300	1000	200	1000	75	1000
9	200	1200	100	1200	400	1200	250	1200	100	1200
10	250	1400	125	1400	500	1400	300	1400	125	1400
11	300	1600	150	1600	600	1600	400	1600	150	1600
12	350	1800	175	1800	700	1800	500	1800	175	1800
13	400	2000	200	2000	800	2000	540	2000	200	2000
14	450	2500	225	2500	900	2500	600	2500	225	2500
15	700	3000	360	3000	1100	3000	750	3000	400	3000

	LEFS32H		LEFS32A		LEFS32B		LEFS40H		LEFS40A		LEFS40B	
	speed [mm/s]	acceler ation [mm/s ²]	speed [mm/s]	acceler ation [mm/s ²]	speed [mm/s]	acceler ation [mm/s ²]	speed [mm/s]	acceler ation [mm/s ²]	speed [mm/s]	acceler ation [mm/s ²]	speed [mm/s]	acceler ation [mm/s ²]
0	24	200	16	200	8	200	30	200	20	200	10	200
1	30	300	20	300	10	300	40	300	30	300	12	300
2	40	400	30	400	15	400	50	400	40	400	15	400
3	50	500	40	500	20	500	60	500	50	500	20	500
4	60	600	50	600	25	600	80	600	60	600	25	600
5	80	700	60	700	30	700	100	700	80	700	30	700
6	100	800	80	800	40	800	200	800	100	800	40	800
7	200	900	100	900	50	900	300	900	200	900	50	900
8	300	1000	200	1000	75	1000	500	1000	300	1000	75	1000
9	400	1200	300	1200	100	1200	600	1200	400	1200	100	1200
10	500	1400	400	1400	125	1400	700	1400	500	1400	125	1400
11	600	1600	500	1600	150	1600	780	1600	520	1600	150	1600
12	750	1800	600	1800	175	1800	930	1800	620	1800	175	1800
13	930	2000	620	2000	200	2000	1000	2000	760	2000	200	2000
14	1000	2500	700	2500	225	2500	1140	2500	800	2500	225	2500
15	1200	3000	800	3000	520	3000	1200	3000	1000	3000	300	3000

10.2 Initial setting value of LEH series

Initial setting values of the LEH series are shown below.

Refer to the table below for the initial setting of Return to origin, jog and inching.

		Common for all LEHF series	Common for all LEH (S, Z) series
Return to origin	Direction	Closed side (Clamped side)	
	speed [mm/s]	10	
	acceleration [mm/s ²]	2000	
Jog	speed [mm/s]	5 (basic type), 10 (Long type)	5
	acceleration [mm/s ²]	1000	
Inching	Distnace[mm]	1	1

Refer to the table below for the set value for 3 levels of pushing force of LEHF series. Pushing speed is fixed at 5 mm/s.

		LEHF10	LEHF20	LEHF32	LEHF40
Pushing force [N]	Low	3	11	48	72
	Middle	5	19.5	84	126
	High	7	28	120	180

*Pushing force accuracy --> LEHS10: $\pm 30\%$ F.S., LEHS20: $\pm 25\%$ F.S., LEHS32, 40: $\pm 20\%$ F.S. Refer to the operation manual of the actuator for details.

Refer to the table below for the set value for 3 levels of pushing force of the LEHS series. Pushing speed is fixed at 5 mm/s.

		LEHS10		LEHS20		LEHS 32	LEHS 40
		Basic	Compact	Basic	Compact		
Pushing force [N]	Low	2.2	1.4	9	7	36	52
	Middle	3.9	2.5	15.5	12	63	91
	High	5.5	3.5	22	17	90	130

*Pushing force accuracy -> LEHS10: $\pm 30\%$ F.S., LEHS20: $\pm 25\%$ F.S., LEHS32, 40: $\pm 20\%$ F.S. Refer to the operation manual of the actuator for details.

Refer to the table below for the set value for 3 levels of pushing force of the LEHZ series. Pushing speed is fixed at 5 mm/s.

		LEHZ10		LEHZ16		LEHZ20、25		LEHZ 32	LEHZ 40
		Basic	Compact	Basic	Compact	Basic	Compact		
Pushing force [N]	Low	6	2 (3)	6	3 (4)	16	11	52	84
	Middle	10	4	10	5.5	28	19.5	91	147
	High	14	6	14	8	40	28	130	210

*Pushing force accuracy -> LEHZ10, 16: $\pm 30\%$ F.S., LEHZ20, 25: $\pm 25\%$ F.S., LEHZ32, 40: $\pm 20\%$ F.S. Refer to the operation manual of the actuator for details.

* The values in parenthesis are for dust cover type (LEHZJ series). The values without parenthesis are common values.

Refer to the table below for the speed / acceleration of LEHF series.

	LEHF10		LEHF20		LEHF32		LEHF40	
	speed [mm/s]	acceler ation [mm/s ²]	speed [mm/s]	acceler ation [mm/s ²]	speed [mm/s]	acceler ation [mm/s ²]	speed [mm/s]	accele ration [mm/s ²]
0	5	100	5	100	5	100	5	100
1	10	150	10	150	10	150	10	150
2	15	200	15	200	15	200	15	200
3	20	300	20	300	20	300	20	300
4	25	400	25	400	25	400	25	400
5	30	500	30	500	30	500	30	500
6	35	600	35	600	35	600	35	600
7	40	700	40	700	40	700	40	700
8	45	800	45	800	45	800	45	800
9	50	900	50	900	50	900	50	900
10	55	1000	55	1000	55	1000	55	1000
11	60	1200	60	1200	60	1200	60	1200
12	65	1400	70	1400	70	1400	70	1400
13	70	1600	80	1600	80	1600	80	1600
14	75	1800	90	1800	90	1800	90	1800
15	80	2000	100	2000	100	2000	100	2000

Refer to the table below for the speed / acceleration of LEHS series.

	LEHS10		LEHS20		LEHS32		LEHS40	
	speed [mm/s]	acceleration [mm/s ²]	speed [mm/s]	acceleration [mm/s ²]	speed [mm/s]	acceleration [mm/s ²]	speed [mm/s]	acceleration [mm/s ²]
0	5	100	5	100	5	100	5	100
1	7	150	10	150	10	150	10	150
2	10	200	15	200	15	200	15	200
3	12	300	20	300	20	300	20	300
4	15	400	25	400	25	400	25	400
5	20	500	30	500	30	500	30	500
6	25	600	35	600	35	600	35	600
7	30	700	40	700	40	700	40	700
8	35	800	45	800	45	800	50	800
9	40	900	50	900	50	900	60	900
10	45	1000	55	1000	55	1000	70	1000
11	50	1200	60	1200	60	1200	80	1200
12	55	1400	65	1400	70	1400	90	1400
13	60	1600	70	1600	80	1600	100	1600
14	65	1800	75	1800	90	1800	110	1800
15	70	2000	80	2000	100	2000	120	2000

Refer to the table below for the speed / acceleration of LEHZ series.

	LEHZ10		LEHZ16		LEHZ20		LEHZ25	
	speed [mm/s]	acceleration [mm/s ²]	speed [mm/s]	acceleration [mm/s ²]	speed [mm/s]	acceleration [mm/s ²]	speed [mm/s]	acceleration [mm/s ²]
0	5	100	5	100	5	100	5	100
1	10	150	10	150	10	150	10	150
2	15	200	15	200	15	200	15	200
3	20	300	20	300	20	300	20	300
4	25	400	25	400	25	400	25	400
5	30	500	30	500	30	500	30	500
6	35	600	35	600	35	600	35	600
7	40	700	40	700	40	700	40	700
8	45	800	45	800	45	800	45	800
9	50	900	50	900	50	900	50	900
10	55	1000	55	1000	55	1000	55	1000
11	60	1200	60	1200	60	1200	60	1200
12	65	1400	65	1400	70	1400	70	1400
13	70	1600	70	1600	80	1600	80	1600
14	75	1800	75	1800	90	1800	90	1800
15	80	2000	80	2000	100	2000	100	2000

	LEHZ32		LEHZ40	
	speed [mm/s]	acceleration [mm/s ²]	speed [mm/s]	acceleration [mm/s ²]
0	5	100	5	100
1	10	150	10	150
2	15	200	15	200
3	20	300	20	300
4	25	400	25	400
5	30	500	30	500
6	35	600	35	600
7	40	700	40	700
8	50	800	50	800
9	60	900	60	900
10	70	1000	70	1000
11	80	1200	80	1200
12	90	1400	90	1400
13	100	1600	100	1600
14	110	1800	110	1800
15	120	2000	120	2000

10.3 Initial setting value of LES series

Initial setting values of the LES series are shown below.

Refer to the table below for initial setting of Return to origin, jog and inching.

		Common for all LES series
Return to origin	Direction	Table retracted side
	speed [mm/s]	20
	acceleration [mm/s ²]	100
Jog	speed [mm/s]	20
	acceleration [mm/s ²]	500
Inching	Distance[mm]	1

Refer to the table below for the set value for 3 levels of pushing force. Pushing speed is fixed at 20 mm/s for LESH**J and at 10 mm/s for LESH**K.

		LESH8R		LESH16R		LESH25R	
		J	K	J	K	J	K
Pushing force [N]	Low	4	6	15	23.5	43	77
	Middle	7	10.5	25	39	71.5	128.5
	High	10	15	35	55	100	180

*Pushing force accuracy is $\pm 20\%$ F.S. Refer to the operation manual of the actuator for details.

Refer to the table below for the speed and the acceleration of the LES series.

	LESH8,16RJ		LESH8,16RK		LESH25RJ		LESH25RK	
	speed [mm/s]	acceleration [mm/s ²]	speed [mm/s]	acceleration [mm/s ²]	speed [mm/s]	acceleration [mm/s ²]	speed [mm/s]	acceleration [mm/s ²]
0	20	300	10	300	20	300	10	300
1	25	400	13	400	25	400	15	400
2	30	500	15	500	30	500	20	500
3	40	600	20	600	40	600	30	600
4	50	700	25	700	50	700	40	700
5	60	800	30	800	60	800	50	800
6	70	900	35	900	70	900	60	900
7	80	1000	40	1000	80	1000	70	1000
8	90	1500	45	1500	90	1500	80	1500
9	100	2000	50	2000	100	2000	90	2000
10	150	2500	75	2500	150	2500	100	2500
11	200	3000	100	3000	200	3000	110	3000
12	250	3500	125	3500	250	3500	120	3500
13	300	4000	150	4000	300	4000	130	4000
14	350	4500	175	4500	350	4500	140	4500
15	400	5000	200	5000	400	5000	150	5000

10.4 Initial setting value of LEY and LEYG series

Initial setting values of the LEY / LEYG series are shown below.

Refer to the table below for initial setting of Return to origin, jog and inching.

		Common for all LEY / LEYG series	
Return to home origin	Direction	Rod retracted side	
	speed [mm/s]	20	
	acceleration [mm/s ²]	1000	
Jog	speed [mm/s]	10	
	acceleration [mm/s ²]	1000	
Inching	Distance[mm]	1	

Refer to the table below for the set value for 3 levels of pushing force and the pushing speed. Pushing speed is fixed.

		LEY16/LEYG16			LEY25/LEYG25			LEY32/LEYG32			LEY40/LEYG40		
		A	B	C	A	B	C	A	B	C	A	B	C
Pushing force [N]	Low	14	27	51	63	126	232	80	156	296	156	298	570
	Middle	26	50.5	96	92.5	182	342	134.5	263	501.5	218	425	814
	High	38	74	141	122	238	452	189	370	707	283	553	1058
Pushing speed [mm/s]		15	8	4	18	9	5	24	12	6	24	12	6

*Pushing force accuracy is $\pm 20\%$ F.S. Refer to the operation manual of the actuator for details.

Refer to the table below for the speed and the acceleration of the LEY and LEYG series.

	LEY16A/LEYG16A		LEY16B/LEYG16B		LEY16C/LEYG16C	
	speed [mm/s]	acceleration [mm/s ²]	speed [mm/s]	acceleration [mm/s ²]	speed [mm/s]	acceleration [mm/s ²]
0	15	200	8	200	4	200
1	20	300	10	300	6	300
2	30	400	15	400	8	400
3	40	500	20	500	10	500
4	50	600	25	600	13	600
5	60	700	30	700	15	700
6	80	800	40	800	20	800
7	100	900	50	900	25	900
8	150	1000	75	1000	38	1000
9	200	1200	100	1200	50	1200
10	250	1400	125	1400	63	1400
11	300	1600	150	1600	75	1600
12	350	1800	175	1800	88	1800
13	400	2000	200	2000	100	2000
14	450	2500	225	2500	113	2500
15	500	3000	250	3000	125	3000

	LEY25A/LEYG25A		LEY25B/LEYG25B		LEY25C/LEYG25C	
	speed [mm/s]	acceleration [mm/s ²]	speed [mm/s]	acceleration [mm/s ²]	speed [mm/s]	acceleration [mm/s ²]
0	18	200	9	200	5	200
1	24	300	12	300	7	300
2	36	400	18	400	9	400
3	48	500	24	500	12	500
4	60	600	30	600	15	600
5	72	700	36	700	18	700
6	84	800	42	800	21	800
7	100	900	50	900	25	900
8	150	1000	75	1000	38	1000
9	200	1200	100	1200	50	1200
10	250	1400	125	1400	63	1400
11	300	1600	150	1600	75	1600
12	350	1800	175	1800	88	1800
13	400	2000	200	2000	100	2000
14	450	2500	225	2500	113	2500
15	500	3000	250	3000	125	3000

	LEY32A/LEYG32A		LEY32B/LEYG32B		LEY32C/LEYG32C	
	speed [mm/s]	acceleration [mm/s ²]	speed [mm/s]	acceleration [mm/s ²]	speed [mm/s]	acceleration [mm/s ²]
0	24	200	12	200	6	200
1	32	300	19	300	15	300
2	40	400	23	400	20	400
3	48	500	27	500	30	500
4	56	600	32	600	40	600
5	64	700	44	700	50	700
6	80	800	54	800	60	800
7	100	900	77	900	70	900
8	150	1000	90	1000	80	1000
9	200	1200	120	1200	90	1200
10	250	1400	150	1400	100	1400
11	300	1600	180	1600	110	1600
12	350	1800	210	1800	120	1800
13	400	2000	240	2000	130	2000
14	450	2500	270	2500	140	2500
15	500	3000	300	3000	150	3000

	LEY40A/LEYG40A		LEY40B/LEYG40B		LEY40C/LEYG40C	
	speed [mm/s]	acceleration [mm/s ²]	speed [mm/s]	acceleration [mm/s ²]	speed [mm/s]	acceleration [mm/s ²]
0	24	200	12	200	6	200
1	32	300	20	300	10	300
2	40	400	35	400	14	400
3	48	500	50	500	18	500
4	56	600	65	600	24	600
5	64	700	80	700	30	700
6	80	800	95	800	36	800
7	100	900	110	900	42	900
8	150	1000	140	1000	48	1000
9	200	1200	170	1200	55	1200
10	250	1400	200	1400	65	1400
11	300	1600	230	1600	75	1600
12	350	1800	260	1800	100	1800
13	400	2000	290	2000	125	2000
14	450	2500	320	2500	150	2500
15	500	3000	350	3000	175	3000

10.5 Initial setting value of LER series

Initial setting values of the LER series are shown below.

Refer to the table below for initial setting of Return to origin, jog and inching.

		LER□□□K series	LER□□□J series
Return to origin	Direction	Counterclockwise (CCW)	Counterclockwise (CCW)
	speed [°/s]	20	30
	acceleration [°/s ²]	20	20
Jog	speed [°/s]	20	30
	acceleration [°/s ²]	1000	1000
Inching	Distance[°]	1	1

During pushing operation of the LER series, the indication of the 7-segment LED of the controller varies, but the pushing torque is as shown in the table below regardless any of the 3 pushing force levels is selected. Pushing speed is fixed at 20 [°/s] for LER***K and at 30 [°/s] for LER***J.

	LER10		LER30		LER50	
	K	J	K	J	K	J
Pushing torque [N · m]	0.16	0.11	0.6	0.4	5.0	3.3

*Pushing torque accuracy -> LER10□: ±30%F.S., LER30□: ±25%F.S., LER50□: ±20%F.S.

*Refer to the operation manual of the actuator for details.

Refer to the table below for the speed and the acceleration.

	LER***K		LER***J	
	Angular speed [°/s]	Angular acceleration [°/s ²]	Angular speed [°/s]	Angular acceleration [°/s ²]
0	20	200	30	200
1	30	300	50	300
2	40	400	60	400
3	50	500	80	500
4	60	600	100	600
5	70	700	120	700
6	80	800	140	800
7	90	900	160	900
8	100	1000	180	1000
9	110	1200	200	1200
10	130	1400	220	1400
11	150	1600	260	1600
12	170	1800	300	1800
13	200	2000	340	2000
14	230	2500	380	2500
15	280	3000	420	3000

10.6 Initial setting value of LEP series

Initial setting values of the LEP (LEPY / LEPS) series are shown below.

Refer to the table below for initial setting of Return to origin, jog and inching.

		LEP□□-□J	LEP□□-□K
Return to origin	Direction	Rod and table retracted side	
	speed [mm/s]	20	10
	acceleration [mm/s ²]	1000	1000
Jog	speed [mm/s]	20	10
	acceleration [mm/s ²]	1000	1000
Inching	Distance[mm]	1	1

Refer to the table below for the set value for 3 levels of pushing force and the pushing speed. Pushing speed is fixed.

		LEP□6		LEP□10L (Compact)		LEP□10 (Basic)	
		J	K	J	K	J	K
Pushing force [N]	Low	7	14	12	24	12.5	25
	Middle	8.5	17	16	32	19	37.5
	High	10	20	20	40	25	50
Pushing speed [mm/s]		20	10	20	10	20	10

*Pushing force accuracy is $\pm 30\%$ F.S. for the LEP□6 and $\pm 25\%$ F.S. for the LEP□10.

Refer to the operation manual of the actuator for details.

Refer to the table below for the speed and the acceleration of the LEP series.

	LEP□6-□J		LEP□6-□K		LEP□10(L)-□J		LEP□10(L)-□K	
	speed [mm/s]	acceleration [mm/s ²]	speed [mm/s]	acceleration [mm/s ²]	speed [mm/s]	acceleration [mm/s ²]	speed [mm/s]	acceleration [mm/s ²]
0	20	200	10	200	20	200	10	200
1	30	300	15	300	30	300	15	300
2	40	400	20	400	40	400	20	400
3	50	500	30	500	50	500	30	500
4	60	600	40	600	75	600	40	600
5	70	700	50	700	100	700	50	700
6	80	800	60	800	125	800	60	800
7	100	900	70	900	150	900	70	900
8	125	1000	80	1000	175	1000	80	1000
9	150	1200	90	1200	200	1200	90	1200
10	175	1400	100	1400	225	1400	100	1400
11	200	1600	110	1600	250	1600	120	1600
12	225	1800	120	1800	275	1800	140	1800
13	250	2000	130	2000	300	2000	160	2000
14	275	2500	140	2500	325	2500	180	2500
15	300	3000	150	3000	350	3000	200	3000

10.7 Initial setting value of LEL series

Initial setting values of the LEL series are shown below.

Refer to the table below for initial setting of Return to origin, jog and inching.

		Common for all LEL series
Return to origin	Direction	Motor side
	speed [mm/s]	80
	acceleration [mm/s ²]	1000
Jog	speed [mm/s]	100
	acceleration [mm/s ²]	1000
Inching	Distance[mm]	10

Refer to the table below for the speed and the acceleration of the LEL series.

	LEL25M		LEL25L	
	speed [mm/s]	acceleration [mm/s ²]	speed [mm/s]	acceleration [mm/s ²]
0	50	200	50	200
1	60	300	60	300
2	70	400	70	400
3	80	500	80	500
4	100	600	100	600
5	120	700	150	700
6	140	800	200	800
7	160	900	250	900
8	180	1000	300	1000
9	200	1200	400	1200
10	250	1400	500	1400
11	300	1600	600	1600
12	350	1800	700	1800
13	400	2000	800	2000
14	450	2500	900	2500
15	500	3000	1000	3000

10.8 Initial setting value of LEM series

Initial setting values of the LEM series are shown below.

Refer to the table below for initial setting of Return to origin, jog and inching.

		Common for all LEM series
Return to origin	Direction	Motor side
	speed [mm/s]	60
	acceleration [mm/s ²]	500
Jog	speed [mm/s]	48
	acceleration [mm/s ²]	1000
Inching	Distance[mm]	0.12

Refer to the table below for the speed and the acceleration of the LEM series.

	LEMB25, LEMB32, LEMC25, LEMC32		LEMH25, LEMHT32, LEMH25, LEMHT32	
	speed [mm/s]	acceleration [mm/s ²]	speed [mm/s]	acceleration [mm/s ²]
0	48	250	48	250
1	75	500	75	500
2	100	1000	100	1000
3	150	1500	150	1500
4	200	2000	200	2000
5	250	2500	300	2500
6	300	3000	400	3000
7	350	4000	500	4000
8	400	5000	600	5000
9	450	6000	800	6000
10	500	7500	1000	7500
11	600	10000	1200	10000
12	700	12500	1400	12500
13	800	15000	1600	15000
14	900	17500	1800	17500
15	1000	20000	2000	20000

11. Options

11.1 Actuator cable [5 m or less]

LE-CP-□□

Cable length (L)

1	1.5 m
3	3 m
5	5 m

Actuator cable type

Nil	Robot cable
S	Standard cable

(1)

Signal	Terminal No.
A	B-1
\bar{A}	A-1
B	B-2
\bar{B}	A-2
COM-A/COM	B-3
COM-B/-	A-3
Shield	
Vcc	B-4
GND	A-4
\bar{A}	B-5
A	A-5
\bar{B}	B-6
B	A-6

(2)

Cable color	Terminal No.
Brown	2
Red	1
Orange	6
Yellow	5
Green	3
Blue	4

(3)

Cable color	Terminal No.
Brown	12
Black	13
Red	7
Black	6
Orange	9
Black	8
-	3

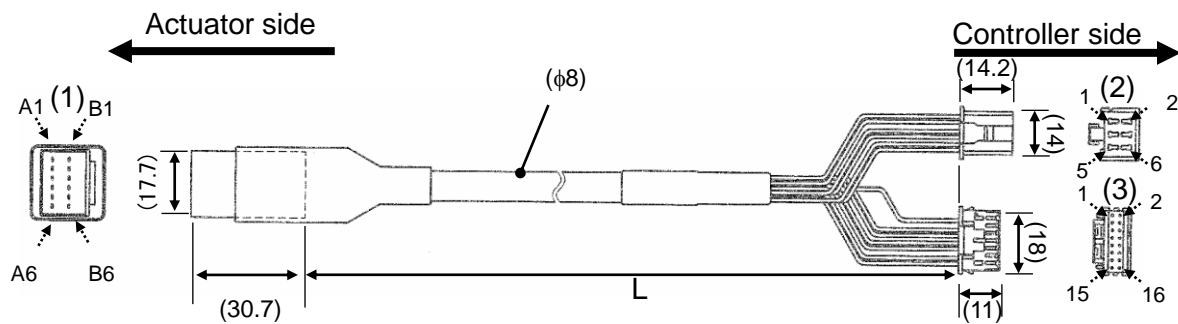

11.2 Actuator cable [8 to 20m]

LE-CP-□□

Cable length (L)

8	8 m *
A	10 m *
B	15 m *
C	20 m *

(1)

Signal	Terminal No.
A	B-1
\bar{A}	A-1
B	B-2
\bar{B}	A-2
COM-A/COM	B-3
COM-B/-	A-3
Shield	
Vcc	B-4
GND	A-4
\bar{A}	B-5
A	A-5
\bar{B}	B-6
B	A-6

(2)

Cable color	Terminal No.
Brown	2
Red	1
Orange	6
Yellow	5
Green	3
Blue	4

(3)

Cable color	Terminal No.
Brown	12
Black	13
Red	7
Black	6
Orange	9
Black	8
-	3

- * Made to order
- * Only "Robotic type cable" can be selected.
- * Transporting performance is reduced by the voltage drop of the cable

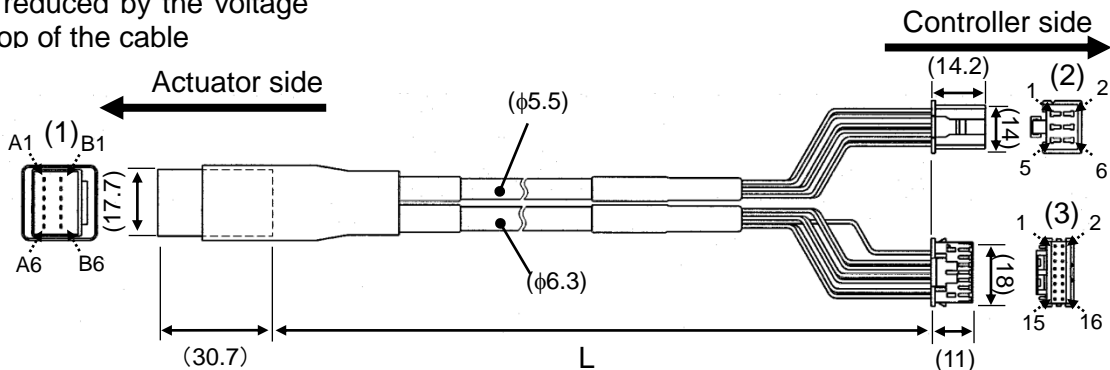

11.3 Actuator cable (for sensor / lock) [5 m or less]

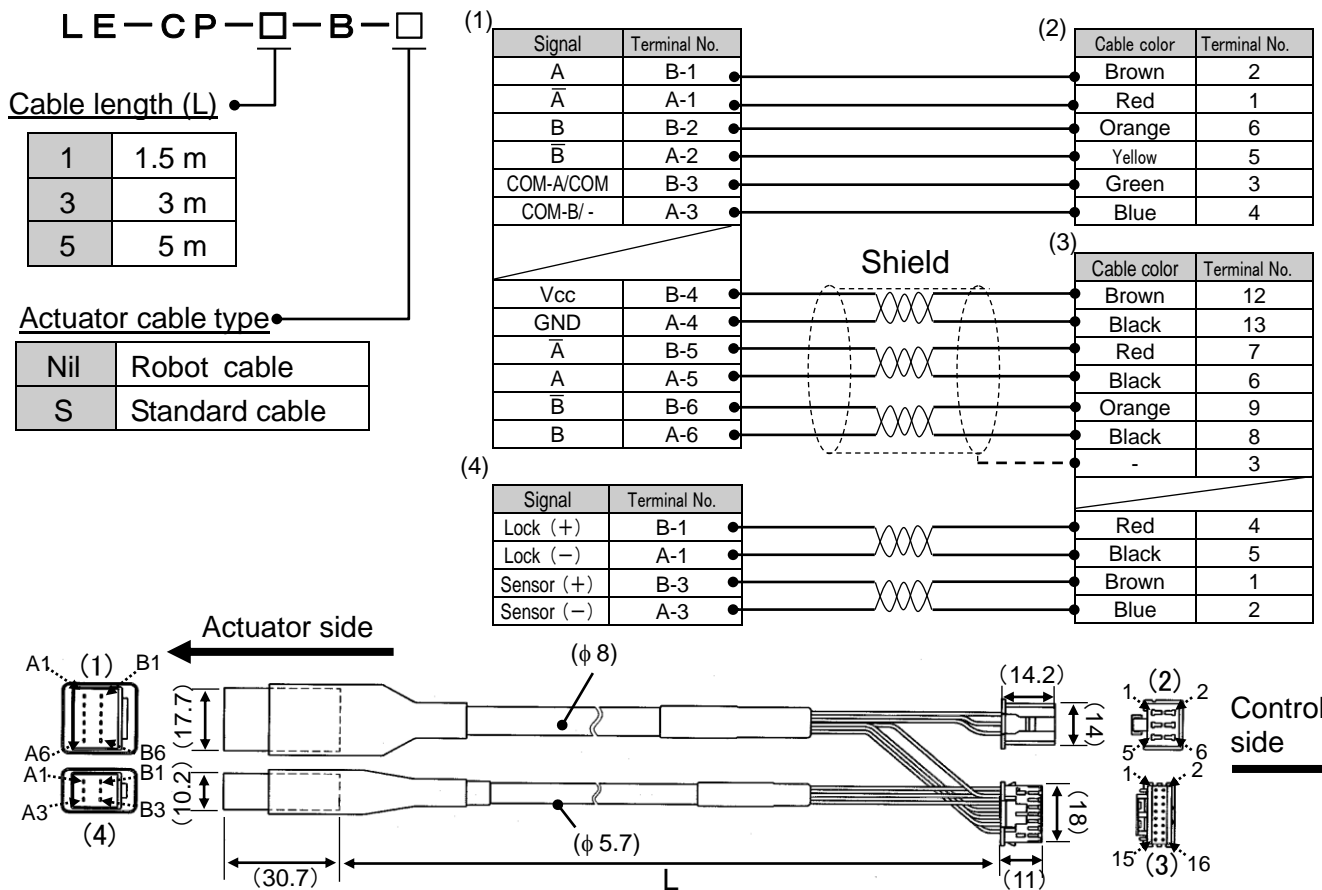

11.4 Actuator cable (for sensor / lock) [8 to 20 m]

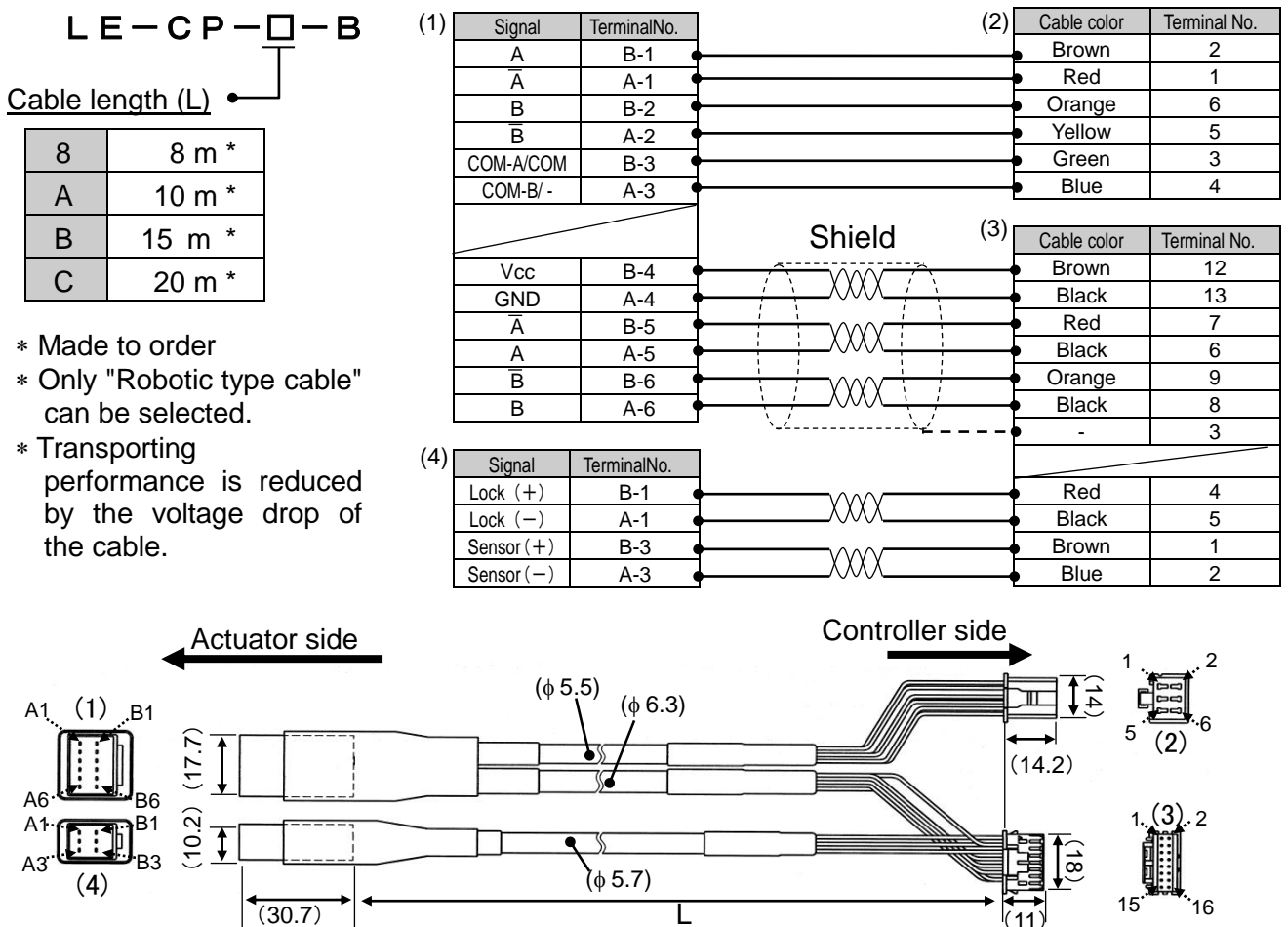

12. Alarm detection

Details of the alarm can be checked by the controller LED indication and parallel I/O terminal. (When the alarm is generated at the manual mode, the alarm is displayed only in 7-segment LED.)

When an alarm is generated, reset the alarm after taking countermeasures and correcting the error by referring to “12.2 Alarms and countermeasures” .

Alarms are divided into two types. One type can be cleared by pressing the set button (g) or inputting the RESET I/O signal. The other type cannot be cleared unless the power supply control (C24V) is turned off and on once.

12.1 Alarm group output

This controller outputs the LED and signal from I/O so that the alarm type can be recognizable when alarm is generated. For alarms, LED (b) lights up in red and the alarm group is indicated by the 7-segment LED (f). The presence of an alarm is indicated by ALARM signal from I/O, and if an alarm is generated, the alarm group is indicated by OUT0 to OUT3.

When multiple numbers of alarms are generated, the 7-segment LED displays a digit signifying the severity of the alarm group. 【 Light A – B – C – D – E Severe 】

Alarm group	7-segment LED Display	Parallel signal output					How to restart the operation
		ALARM *1, 2	OUT0	OUT1	OUT2	OUT3	
A	A	OFF	ON	OFF	OFF	OFF	Input RESET or set the button (g)
B	b	OFF	OFF	ON	OFF	OFF	
C	c	OFF	OFF	OFF	ON	OFF	
D	d	OFF	OFF	OFF	OFF	ON	
E	E	OFF	OFF	OFF	OFF	OFF	Power supply for control is cycled turned off --> and then turned on.

When multiple alarms in alarm groups A to D occur, the relevant OUT 0 to 3 will be ON.

However, when alarm group E occurs, regardless of any other alarms that may be occurring, OUT 0 to 3 will all be OFF.

*1 When the alarm is generated, ALARM is turned off due to N.C. type.

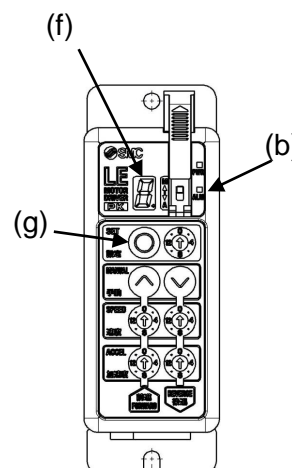

*2 When the servo is turned OFF, ALARM output is turned OFF. The generated alarm cannot be identified only by ALARM outputs.

*3 Parallel output signals are disabled during manual mode.



12.2 Alarms and countermeasures

Group	The condition of the controller when an alarm is generated	How to reset	Conditions / Countermeasures
A	Manual mode Servo is OFF	Press the Set button (Input RESET)	<p>< Condition > During intermediate position registration by direct teaching, the position is registered before return to origin.</p> <p><Countermeasure> Perform return to origin.</p>
B	Any condition	Input RESET (Press the Set button)	<p><Condition> Problem occurred with the controller data or parameters.</p> <p><Countermeasure> If the problem is not solved by supplying power again, contact SMC.</p>
C	During or after pushing operation	Input RESET (Press the Set button)	<p><Condition> During the pushing operation, the actuator is pushed back beyond the start position of pushing</p> <p><Countermeasure> Set a larger pushing thrust force or reduce the reaction force of the load. Refer to 8.3 Pushing operation for details of pushing operation.</p>
C	Stopped	Input RESET (Press the Set button)	<p><Condition> Command for return to origin, positioning, pushing or jog operation is sent when the servo is off.</p> <p><Countermeasure> Check if I/O signal STOP is input. Also, check if the servo is OFF in manual mode. Refer to 8.5 Servo ON for turning off the servo.</p>
C	Stopped	Input RESET (Press the Set button)	<p><Condition> Command for positioning or pushing is sent before return to origin is completed.</p> <p><Countermeasure> Start operation after the completion of the return to origin. Return to origin must be performed after a group D alarm is generated and deactivated.</p>
D	During operation	Input RESET (Press the Set button)	<p><Condition> The number of motor rotations exceeds the specified number.</p> <p><Countermeasure> If an external force is being applied, remove it. If there is no external force being applied, and the problem is not solved by supplying power again, please contact SMC.</p>

Group	The condition of the controller when an alarm is generated	How to reset	Conditions / Countermeasures
D	During operation	Input RESET (Press the Set button)	<p><Condition> The power supply voltage for motor which is detected in the controller is outside of the specified range. The alarm may be generated when the regenerated power of the motor is large.</p> <p><Countermeasure> Check the voltage supplied to the power supply for the controller motor (M24V). Check if the operating condition of the actuator is within the specification range.</p> <div style="border: 1px solid black; padding: 5px; text-align: center;">  Caution </div> <p>If the power supply is an inrush current suppressor type, a voltage drop may occur during acceleration/deceleration, generating an alarm.</p>
D	Any condition	Input RESET (Press the Set button)	<p><Condition> The temperature around the power element of the controller is too high.</p> <p><Countermeasure> Check the mounting condition of the controller and improve the ambient temperature of the controller to an appropriate temperature. Refer to 3.4 Mounting method for the mounting conditions of the controller.</p>
D	Any condition	Input RESET (Press the Set button)	<p><Condition> The power supply voltage for control which is detected in the controller is outside of the specified range.</p> <p><Countermeasure> Check the voltage applied to the control power supply for the controller (C24V).</p> <div style="border: 1px solid black; padding: 5px; text-align: center;">  Caution </div> <p>If a single power supply is used for both the control power and the motor power, or the power supply is “inrush-current control type”, a power voltage drop may occur during acceleration/deceleration, generating an alarm.</p>
D	During or after suspension of operation	Input RESET (Press the Set button)	<p><Condition> The time to reach the target position is longer than the specified value.</p> <p><Countermeasure> Check if the travel of the actuator was interrupted.</p>
E	Immediately after applying power	Shut off the control power supply	<p><Condition> This alarm occurs when an abnormality is detected in the encoder signals.</p> <p><Countermeasure> Please check whether there are any loose connections or any damage to the connector of the controller and/or actuator. Please check whether there is any damage to the actuator cable (severed wires, etc.)</p>

Group	The condition of the controller when an alarm is generated	How to reset	Conditions / Countermeasures
E	immediately after applying power	Shut off the control power supply	<p><Condition> Positioning of the polarity is not completed properly. The actuator slightly moves to detect the polarity of the motor after power is supplied. If the actuator cannot be moved at that time, this alarm will be generated.</p> <p><Countermeasure> Supply power in conditions in which the actuator is operable.</p>
E	immediately after applying power	Shut off the control power supply	<p><Condition> An abnormality with the current sensors which is recognized when the controller is initialized is detected.</p> <p><Countermeasure> Please check that the motor is not operated by external force during servo ON. Install the actuator vertically and check that the BK RLS is not energized. Confirm the combination of the controller and the actuator is correct. If the problem is not solved by supplying power again, please contact SMC.</p>
E	During operation	Shut off the control power supply	<p><Condition> Position deviation counter in the controller is overflowed.</p> <p><Countermeasure> Check if the travel of the actuator is interrupted. Check if the load of the actuator is within the specification range.</p>
E	Any condition	Shut off the control power supply	<p><Condition> Output current at the power supply circuit is abnormally high.</p> <p><Countermeasure> Check if the actuator cable or connector is short-circuited. Confirm the combination of the controller and the actuator is correct.</p>
E	Any condition	Shut off the control power supply	<p><Condition> Abnormality concerning EEPROM is confirmed.</p> <p><Countermeasure> If the problem is not solved by supplying power again, please contact SMC (The write limit of the EEPROM is roughly 100,000 times).</p>
E	Any condition	Shut off the control power supply	<p><Condition> CPU is not operating properly. (Failure of CPU and peripheral circuits, or malfunction due to noise)</p> <p><Countermeasure> If the problem is not solved by supplying power again, please contact SMC.</p>

13. Wiring of cables/Common precautions

⚠Warning

1. **Adjustment, mounting or wiring should never be carried out before shutting off the power supply to the product.**

Electrical shock, malfunction and damaged can result.

2. **Never disassemble the cable. Use only specified cables.**
3. **Never connect or disconnect the cable or connector with the power on.**

⚠Caution

1. **Wire the connector securely. Do not apply any voltage to the terminals other than those specified in the product Manual.**
2. **Wire the connector securely.**
Check for correct connector wiring and polarity.
3. **Take appropriate measures against noise.**
Noise in a signal line may cause malfunction. As a countermeasure, high voltage and low voltage cables should be separated, and keep wiring lengths short, etc.
4. **Do not route wires and cables together with power or high voltage cables.**
The product can malfunction due to interference and surge voltage cables. Route the wires to the product separately from power or high voltage cables.
5. **Take care that actuator movement does not damage cables.**
6. **Operate with cables secured. Avoid bending cables at sharp angles where they enter the product.**
7. **Avoid twisting, folding, rotating or applying an external force to the cable.**
Risk of electric shock, wire break, contact failure and lost of control for the product can happen.
8. **Fix the cable protruding from the product in place before using.**
The motor and lock cables are not robotic type cables and can be damaged when moved. Therefore, fix the cables and the connectors (part "A" in figure below) during set up

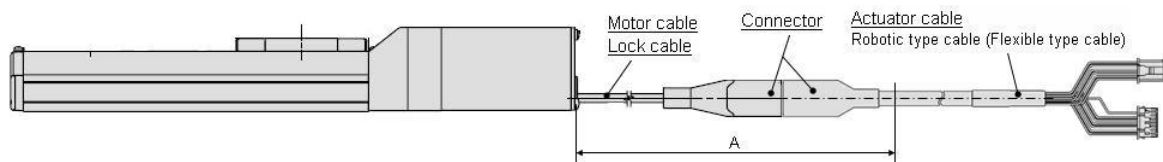

9. **Select "Robotic type cables" when deflecting actuator-cables repeatedly. Do not put cables into a flexible moving tube with a radius smaller than the specified value (minimum 50mm).**
Risk of electric shock, broken wires, contact failure and loss of control of the product can occur. If "Standard cables" are used when the cables deflecting repeatedly
-
- The diagram shows a cable being deflected through a curved path. The radius of the curve is labeled as R50. This illustrates the minimum bending radius for the cables.
10. **Confirm correct wiring of the product.**
Poor insulation (interference with other circuits, poor insulation between terminals and etc.) can apply excessive voltage or current to the product causing damage.
 11. **The Speed/pushing force may vary, depending on the cable length, load and mounting conditions etc.**
If the cable length exceeds 5m, the speed / pushing force will be reduced by a maximum of 10% per 5m. (If the cable length is 15m: Maximum 20% reduction.)

[Transportation]

⚠Caution

1. **Do not carry or swing the product by the motor or the cablethe cable**

14. Electric actuators/ Common precautions

14.1 Design and selection

Warning

- 1. Be sure to read the Operation Manual.**

Handling or usage/operation other than that specified in the Operation Manual may lead to breakage and product failure.
Any damage attributed to use beyond the specifications is not guaranteed.
- 2. There is a possibility of dangerous sudden movement of the product if sliding parts of machinery are twisted due to external forces etc.**

In such cases, human injury may occur, such as by catching hands or feet in the machinery, or damage to the machinery itself may occur. Design the machinery should be designed to avoid such dangers.
- 3. A protective cover is recommended to minimize the risk of personal injury.**

If a driven object and moving parts of the product are in close proximity, personal injury may occur. Design the system to avoid contact with the human body.
- 4. Securely tighten all stationary parts and connected parts so that they will not become loose.**

When the product operates with high frequency or is installed where there is a lot of vibration, ensure that all parts remain secure.
- 5. Consider a possible loss of power source.**

Take measures to prevent injury and equipment damage even in the case of a power supply failure.
- 6. Consider the behavior of an emergency stop of the whole system.**

Design the system so that human injury and/or damage to machinery and equipment will not be caused, when it is stopped by a safety device for abnormal conditions such as a power outage or a manual emergency stop of the whole system.
- 7. Consider the action when operation is restarted after an emergency stop or abnormal stop of the whole system.**

Design the system so that human injury or equipment damage will not occur upon restart of operation of the whole system.
- 8. Disassembly and modification prohibited**

Do not modify or reconstruct (including additional machining) the product. An injury or failure can result.
- 9. When using for vertical applications, it is necessary to build in a safety device.**

The rod may fall due to the weight of the work. The safety device should not interfere with normal operation of the machine.

Caution

- 1. Operate within the limits of the maximum usable stroke.**

The product will be damaged if it is used beyond the maximum stroke. Refer to the specifications of the product.
- 2. When the product repeatedly cycles with partial strokes, operate it at a full stroke at least once a day or every 1000 strokes.**

Otherwise, lubrication can be lost.
- 3. Do not use the product in applications where excessive external force or impact force is applied.**

The product can be damaged. Each component that includes motor is made with accurate tolerances. Even slightly deformed or misaligned of components may lead to product failure.

4. **Refer to a common auto switch (Best Pneumatics No 2), when an auto switch is built and used within the system.**
5. **Return to origin cannot return while operating.**
The function cannot be carried out during positioning operation or pushing operation.
6. **When conformity to UL is required, the electric actuator and controller should be used with a UL1310 Class 2 power supply.**

14.2 Mounting

Warning

1. **Install and operate the product only after reading the Operation Manual carefully and understanding its contents. Keep the manual in a safe place for future reference.**
2. **Observe the tightening torque for the mounting screws.**
Tighten the screws to the recommended torque for mounting the product.
3. **Do not make any alterations to this product.**
Alterations made to this product may lead to a loss of durability and damage to the product, which can lead to human injury and damage to other equipment and machinery.
4. **When using an external guide, the guide axis should be parallel to the actuator axis.**
There will be damage/excessive wear on the lead screw if the external guide is not parallel.
5. **When an external guide is used, connect the moving parts of the product and the load in such a way that there is no interference at any point within the stroke.**
Do not scratch or dent the sliding parts of the product tube or piston rod etc., by striking them with other objects. Components are manufactured to precise tolerances, so the slightest deformation may cause faulty operation.
6. **Do not use the product until you verify that the equipment can be operated properly.**
After mounting or repair, connect the power supply to the product and perform appropriate functional inspections to check it is mounted properly.
7. **At the overhang mounted impeller fixation**
There is a possibility that the power at the bending moment will damage the actuator when moving at high speed.
The metal support fittings which suppress the vibration of the main body of the actuator are installed. Reduce the speed to the condition where the actuator does not vibrate.
8. **When attaching the work piece, do not apply a strong impact or large moment.**
If an external force above the allowable moment is applied, it may cause looseness in the guide unit, an increase in sliding resistance or other problems.
9. **Maintenance space.**
Allow sufficient space for maintenance and inspection.

14.3 Handling

Warning

1. **Do not touch the motor while in operation.**
The surface temperature of the motor can increase to approx. 90°C to 100°C due to operating conditions. Energizing alone may also cause this temperature increase. Do not touch the motor when in operation, as this may cause burns.

2. **If abnormal heating, smoking or fire, etc., occurs in the product, immediately shut off the power supply.**
3. **Immediately stop operation if abnormal operation noise or vibration occurs.**
If abnormal operation noise or vibration occurs, the product may have been mounted incorrectly. Unless operation of the product is stopped for inspection, the product can be seriously damaged.
4. **Never touch the rotating part of the motor or moving part of the actuator while in operation.**
5. **When installing, adjusting, inspecting or performing maintenance on the product, controller and related equipment, be sure to shut off the power supply. Then, lock it so that no other person can turn the power on, or implement measures such as a safety plug.**

Caution

1. **Keep the controller and actuator combination as delivered for use.**
The product parameters are set before shipment. If the controller is combined with a different actuator, failure can result.
2. **Check the product for the following points before operation.**
 - a) Damage to electric drive cable and signal cable.
 - b) Looseness of the connector to the power and signal lines.
 - c) Looseness of the actuator/cylinder and controller/driver mounting
 - d) Abnormal operation
 - e) Emergency stop of the total system
3. **When more than one person is performing work, decide on the procedures, signals, measures and resolution for abnormal conditions before beginning the work. Also, designate a person to supervise work other than those performing work.**
4. **The actual speed of the product will be affected by the workload.**
Before selecting a product, check the catalog for instructions regarding selection and specifications.
5. **Do not apply a load, impact or resistance, in addition to a transferred load during the "Return to Origin" operation.**
In the case of the return to origin by pushing force, additional force will cause displacement of the origin position since it is based on the detected motor torque.
6. **Do not remove the name plate.**
7. **An operation test should be carried out using a low speed. Start operation using the predefined speed after confirming there is no problems.**

[Ground]

Warning

1. **Make sure the product is connected to ground to ensure the noise resistance.**
2. **The ground should be exclusive use. (Less than 100Ω)**
3. **The ground cable length should be as short as possible.**

[Unpackaging]

Caution

1. Verify that the received product is as ordered.

If a different product is installed, other than that ordered, injury or damage can result.

14.4 Operating environment

Warning

1. Avoid use in the following environments.

- a. Locations where a large amount of dust or cutting chips are airborne.
- b. Locations where the ambient temperature is outside the range of the temperature specification (refer to specifications).
- c. Locations where the ambient humidity is outside the range of the humidity specification (refer to specifications).
- d. Locations where corrosive gas, flammable gas, sea water, water and steam are present.
- e. Locations where strong magnetic or electric fields are generated.
- f. Locations where direct vibration or impact is applied to the product.
- g. Areas that are dusty, or are exposed to splashes of water or oil drops.
- h. Areas exposed to direct sunlight (ultraviolet light).
- i. Environment at an altitude of 1000 meters or higher

Heat radiation and withstand voltage will decrease. Contact SMC for details.

2. Do not use in an environment where the product is directly exposed to liquid, such as cutting oils.

If cutting oils, coolant or oil mist contaminates the product, failure or increased sliding resistance can result.

3. Install a protective cover when the product is used in an environment directly exposed to foreign matters such as dust, cutting chips and spatter.

Play or increased sliding resistance can result.

4. Provide a protective cover if the product is used in direct sunlight.

5. Protect the product from radiated heat generated by nearby heat sources.

When there is a heat source surrounding the product, the radiated heat from the heat source can increase the temperature of the product beyond the operating temperature range.

6. Grease oil can be reduced due to the external environment and operating conditions. The lubrication performance may deteriorate and shorten the life of the product.

[Storage]

Warning

1. Do not store the product in direct contact with rain or water drops, or exposed to harmful gas or liquids.
2. Store the product in an area that is shaded from direct sunlight and has a temperature and humidity within the specified range (-10°C to 60°C and 90%RH or less, no condensation or freezing).
3. Do not apply vibration or impact to the product during storage.

14.5 Maintenance

Warning

1. **Do not disassemble or repair the product.**
Fire or electric shock can result.
2. **Before modifying or checking the wiring, the voltage should be checked with a tester 5 minutes after the power supply is turned off.**
Electric shock can result.

Caution

1. **Maintenance should be performed according to the procedure indicated in the Operating Manual.**
Incorrect handling can cause injury, damage or malfunction of equipment and machinery.
2. **Removal of product.**
When equipment is serviced, first confirm that measures are in place to prevent dropping of work pieces and run-away of equipment, etc, then cut the power supply to the system. When machinery is restarted, check that operation is normal with actuators in the proper positions.
3. **When moving the actuator slider manually by hand, please disconnect the actuator cable.**
The actuator cannot be moved smoothly by the induced voltage of the motor goes to the controller when actuator slider is moved with the actuator connected with the controller. Moreover, the controller might break down by the induced voltage when moving the actuator slider at high frequency.

[Lubrication]

Caution

1. **The product has been lubricated for life at the manufacturer's and does not require lubrication in service.**
Contact SMC if lubrication will be applied.

14.6 Precautions for actuator with lock

Warning

1. **Do not use the lock as a safety lock or a control that requires a locking force.**
The lock used for the product with a lock is designed to prevent dropping of work piece.
2. **For vertical mounting, use the product with a lock.**
If the product is not equipped with a lock, the product will move and drop the work piece when the power is removed.
3. **"Measures against drops" means preventing a work piece from dropping due to its weight when the product operation is stopped and the power supply is turned off.**
4. **Do not apply an impact load or strong vibration while the lock is activated.**
If an external impact load or strong vibration is applied to the product, the lock will lose its holding force and damage to the sliding part of the lock or reduced lifetime can result. The same situations will happen when the lock slips due to a force over the thrust of the product, as this accelerates the wear to the lock.
5. **Do not apply liquid or oil and grease to the lock or its surrounding.**
When liquid or oil and grease is applied to the sliding part of the lock, its holding force will reduce significantly.
6. **Take measures against drop and check that safety is assured before mounting, adjustment and inspection of the product.**
If the lock is released with the product mounted vertically, a work piece can drop due to its weight.

15. Controller and its peripheral devices / Specific product precautions

15.1 Design and selection

Warning

1. Be sure to apply the specified voltage.

Otherwise, a malfunction and breakage of the controller may be caused.

If the applied voltage is lower than the specified, it is possible that the load cannot be moved due to an internal voltage drop. Please check the operating voltage before use.

2. Do not operate beyond the specifications.

It may cause a fire, malfunction or actuator damage can result. Please check the specifications before use.

3. Install an emergency stop circuit.

Please install an emergency stop outside of the enclosure so that it can stop the system operation immediately and intercept the power supply.

4. In order to prevent danger and damage due to the breakdown and the malfunction of this product, which may occur at a certain probability, a backup system should be established previously by giving a multiple-layered structure or a fail-safe design to the equipment, etc.

5. If a fire or danger against the personnel is expected due to an abnormal heat generation, ignition, smoking of the product, etc., cut off the power supply for this product and the system immediately.

15.2 Handling

Warning

1. The inside of the controller and its connector should not be touched.

It may cause an electric shock or damage to the controller.

2. Do not perform the operation or setting of this equipment with wet hands.

It may cause an electric shock.

3. Product with damage or the one lacking of any components should not be used.

It may cause an electric shock, fire, or injury.

4. Use only the specified combination between the controller and electric actuator.

It may cause damage to the controller or the actuator.

5. Be careful not to be caught or hit by the workpiece while the actuator is moving.

It may cause an injury.

6. Do not connect the power supply or power on the product before confirming the area where the work moves is safe.

The movement of the work may cause accident.

7. Do not touch the product when it is energized and for some time after power has been disconnected, as it is very hot.

It may lead to a burn due to the high temperature.

8. **Check the voltage using a tester for more than 5 minute after power-off in case of installation, wiring and maintenance.**
There is a possibility of getting electric shock, fire and injury.
9. **Do not use in an area where dust, powder dust, water or oil is in the air.**
It will cause failure or malfunction.
10. **Do not use in an area where a magnetic field is generated.**
It will cause failure or malfunction.
11. **Do not install in the environment of flammable gas, corrosive gas and explosive gas.**
It could lead to fire, explosion and corrosion.
12. **Radiant heat from strong heat supplies such as a furnace, direct sunlight, etc. should not be applied to the product.**
It will cause failure of the controller or its peripheral devices.
13. **Do not use the product in an environment subject to a temperature cycle.**
It will cause failure of the controller or its peripheral devices.
14. **Do not use in a place where surges are generated.**
When there are units that generate a large amount of surge around the product (e.g., solenoid type lifters, high frequency induction furnaces, motors, etc.), this may cause deterioration or damage to the product's internal circuit. Avoid supplies of surge generation and crossed lines.
15. **Do not install this product in an environment under the effect of vibrations and impacts.**
It will cause failure or malfunction.
16. **If this product is used with a relay or solenoid valve, they should be the surge absorbing element built-in type.**

15.3 Installation

Warning

1. **The controller and its peripheral devices should be installed on a fire-proof material.**
A direct installation on or near a flammable material may cause fire.
2. **Do not install this product in a place subject to vibrations and impacts.**
It may cause an electric shock, fire, or injury.
3. **Take measure so that the operating temperature of this controller and its peripheral devices are within the range of the specifications. Also, this controller should be installed with 50mm or larger spaces between each side of it and the other structures or components.**
It may cause a malfunction of the controller and its peripheral devices and a fire.
4. **Do not mount this controller and its peripheral devices together with a large-sized electromagnetic contactor or no-fuse breaker, which generates vibration, on the same panel. Mount them on different panels, or keep the controller and its peripheral devices away from such a vibration supply.**
5. **This controller and its peripheral devices should be installed on a flat surface.**
If the mounting surface is distorted or not flat, an unacceptable force may be added to the housing, etc. to cause troubles.

15.4 Wiring of cables/Common precautions

Warning

- 1. Do not apply any excessive force to cables by repeated bending, tensioning or placing a heavy object on the cables.**
It may cause an electric shock, fire, or breaking of wire.
- 2. Connect wires and cables correctly.**
Incorrect wiring could break the controller or its peripheral devices depending on the seriousness.
- 3. Do not connect wires while the power is supplied.**
It can break the controller or its peripheral devices could be damaged to cause a malfunction.
- 4. Do not carry this product by holding its cables.**
It may cause an injury or damage to the product.
- 5. Do not connect power cable or high-voltage cable in the same wiring route as the unit.**
The wires to the controller or its peripheral devices can be interrupted with noise or induced surge voltage from power lines or high-voltage lines and malfunction could be caused.
Separate the wiring of the controller and its peripheral device from that of power line and high voltage line.
- 6. Verify the insulation of wiring.**
Insulation failure (interference with other circuit, poor insulation between terminals and etc.) could introduce excessive voltage or current to the controller or its peripheral devices and damage them.

15.5 Power supply

Caution

- 1. Use a power supply that has low noise between lines and between power and ground.**
In cases where noise is high, an isolation transformer should be used.
- 2. The power supplies should be separated between the controller power and the I/O signal power and both of them do not use the power supply of “rush-current restraining type”.**
If the power supply is “rush-current restraining type”, a voltage drop may be caused during the acceleration of the actuator.
- 3. To prevent surges from lightning, an appropriate measure should be taken. Ground the surge absorber for lightning separately from the grounding of the controller and its peripheral devices.**

15.6 Grounding

Warning

- 1. The controller must be connected to Ground to reduce noise.**
- 2. Controller mount hole (mounting part for ground cable) is connected to SG (signal ground) in the controller.**
Do not ground the controller when the controller is used in positive grounding environment.

3. **Dedicated grounding should be used.**
Grounding should be to a D-class ground (Ground resistance of 100 Ω or less.)
4. **Grounding should be performed near the unit as much as possible to shorten the grounding distance.**
5. **In the unlikely event that malfunction is caused by the ground, it may be disconnected.**

15.7 Maintenance



Warning

1. **Perform a maintenance check periodically**
Confirm wiring and screws are not loose.
Loose screws or wires may cause unintentional malfunction.
2. **Conduct an appropriate functional inspection after completing the maintenance.**
In case of any abnormalities (in the case that the actuator does not move, etc.), stop the operation of the system. Otherwise, an unexpected malfunction may occur and it will become impossible to secure the safety.
3. **Do not disassemble, modify or repair this controller and the peripheral equipment.**
4. **Do not put anything conductive or flammable inside of this controller.**
It may cause a fire and explosion.
5. **Do not conduct an insulation resistance test and withstand voltage test on this product.**
6. **Ensure sufficient space for maintenance activities. Provide space required for maintenance.**
Design the system that allows required space for maintenance.

16. Troubleshooting

Refer to the table below for troubleshooting. When none of the causes in the troubleshooting can be confirmed and normal operation is recovered by the replacement of a product, it is presumed that failure is in the product.

Problems with the product may be due to the operating environment (application). Please consult us if troubleshooting is necessary.

16.1 Operation troubles

Failure	Possible causes	Investigation method and the location of possible causes	Countermeasures
Does not operate	Power supply failure	Is the green LED on the controller ON?	Check the power, voltage and current supplied to the controller. → 4. External connection → 5. CN1: Power supply cable
	External equipment failure	Does the PLC connected to the controller operate correctly? Check the operation of a single unit of the controller at test run.	Refer to this Operation Manual and take appropriate measures. → 6. CN4: Parallel I/O cable
	Wiring failure	Is the wiring connected correctly? Check if the wiring is connected correctly or if there is broken wire or short-circuit by referring to this Operation Manual.	Correct the wiring and confirm that the input/output of each signal is correct. → 4. External connection → 6.4 Parallel I/O connector wiring (Example)
	Alarm generated	Is controller alarm generated? If yes, check the type of alarm referring to this Operation Manual.	Refer to this Operation Manual and take appropriate measures. → 12. Alarm detection
	Unlocking error	Is lock releasing sound generated when the lock switch is turned on and off?	If there is no sound of lock release, the lock may be broken. -> If the problem is not solved for some time, please contact SMC.
	Unsuitable specification	Check if the controller's specifications are appropriate, the power supply is suitable and the controller is compatible with the actuator.	Check if the product number of the used actuator matches with the actuator which is applicable to the controller. → 2.2 How to Order
	Servo OFF	Is servo OFF (controller green LED flashes)?	Servo is OFF and the operation is not available under the following conditions. Eliminate the cause and follow the operation instruction after the servo is turned ON. - STOP input is ON. - Motor power supply is OFF.

Failure	Possible causes	Investigation method and the location of possible causes	Countermeasures
Operation stops intermittently	Alarm generated	Is controller alarm generated? If yes, check the type of the alarm and take appropriate measures referring to this Operation Manual.	Refer to this Operation Manual and take appropriate measures. → <u>12. Alarm detection</u>
	Wiring failure	Is the wiring connected correctly? Check if the wiring is connected correctly or if there is broken wire or short-circuit by referring to this Operation Manual.	Correct the wiring and confirm that the input/output of each signal is correct. → <u>4. External connection</u> → <u>6.4 Parallel I/O connector wiring (Example)</u>
	Counter-measures against noise	Ground properly. Avoid bundling the cables.	Refer to this Operation Manual and take appropriate measures. → <u>3.4 Mounting</u>
	Voltage drop	Check if there are any temporary voltage drops in the power supply.	There is a possibility of a momentary voltage drop because the capacity of the power supply is insufficient, or if the power supply is "inrush-current control" type. → <u>3.1 Basic specifications</u>
	Pushing operation failure	Is pushing operation performed in manual mode?	Pushing operation is not available in manual mode except for testing. Switch to test function or perform pushing in auto mode. → <u>(C) Manual mode after returning to origin position</u>
	Unsuitable specification	Check if the controller's specifications are appropriate, the power supply is suitable and the actuator is compatible with the controller.	Check if the product number of the used actuator matches with the actuator which is applicable to the controller. → <u>2.2 How to Order</u>
	Servo ON time	When the power supply for the motor is applied (or STOP input is turned off), commands can be given after ALARM output is ON?	Just after the motor power is supplied, it may take 10 seconds until ALARM output depending on the actuator position. Command operation after ALARM output is turned ON.
	Command the position number repeatedly	Is the same position number specified?	The operation is not performed when the position number of the current stop position is specified repeatedly. There is no operation start either when the position number to which the current stop position number is registered is specified. Check if the position number specified before operation, the position number which specifies the position and operation, and the registered position number are not overlapped.

16.2 Position / Speed troubles

Failure	Possible causes	Investigation method and the location of possible causes	Countermeasures
The actuator does not move to the correct position.	Displaced from the origin	In case of return to origin with pushing operation, does the actuator travel to the origin? Perform return to origin several times to check the origin position.	Check if foreign matter is caught in the product by operating the actuator.
	Unsuitable specification	Check if the controller's specifications are appropriate, the power supply is suitable and the actuator is compatible with the controller.	Check if the product number of the used actuator matches with the actuator which is applicable to the controller. → <u>2.2How to Order</u>
Doesn't move to the correct position	Wiring failure	Check if the wiring is correct. Check if the wiring is connected correctly or if there is broken wire or short-circuit by referring to this Operation Manual.	Correct the wiring and confirm that the input/output of each signal is correct. → <u>4. External connection</u> → <u>6.4 Parallel I/O connector wiring (Example)</u>
	Unsuitable specification	Check if the controller's specifications are appropriate, the power supply is suitable and the actuator is compatible with the controller.	Check if the product number of the used actuator matches with the actuator which is applicable to the controller. → <u>2.2How to Order</u>
Speed does not reach the desired speed	Operation pattern is not suitable	Is the operation pattern trapezoidal? If the operation pattern is triangular, it is possible that the actuator will start to decelerate before reaching the maximum speed.	Lengthen the travel distance, or set a larger acceleration value. → <u>7.1 Setting procedure</u>
	Speed change in auto mode	Is the speed or acceleration switches changed in auto mode?	Go to speed adjustment in auto mode to change the speed and acceleration. → <u>(B) Auto mode after return to origin position</u>
	Unsuitable specification	Check if the controller's specifications are appropriate, the power supply is suitable and the actuator is compatible with the controller.	Check if the product number of the used actuator matches with the actuator which is applicable to the controller. → <u>2.2How to Order</u>

Revision history

No. LEC-OM03901

Nov/2012 1st printing

No. LEC-OM03902

Apr/2012 Revision

Model addition(LECP1**D-*)

Addition to note about UL recogritton

No. LEC-OM03903

Jan/2014 Revision

Addition/Troubleshooting

No. LEC-OM03904

Jul/2014 Revision

Addition/Troubleshooting

No. LEC-OM03905

Jan/2015 Recision

Initial setting value of LEF series

No. LEC-OM03906

Jul/2015 Revision

Addition/8.7 LED display in auto mode

Initial setting value of LEY series

No. LEC-OM03907 No. JXC※-OMU0029)

Mar/2017 Revision

- Reviewed 5.2 Description of Wiring of the power supply cable.
- Added display and output when multiple numbers of alarms are generated.
- Added the content of Alarm groupE.

SMC Corporation

4-14-1, Sotokanda, Chiyoda-ku, Tokyo 101-0021 JAPAN

Tel: + 81 3 5207 8249 Fax: +81 3 5298 5362

URL <http://www.smcworld.com>

NOTE: Specifications are subject to change without prior notice and any obligation on the part of the manufacturer.
© 2012-2017 SMC Corporation All Rights Reserved