



F.R.L. Units Precautions 1

Be sure to read this before handling products.

Design/Selection

Warning

1. Confirm the specifications.

Products represented in this catalog are designed only for use in compressed air systems (including vacuum).

Do not operate at pressures, temperatures, etc., beyond the range of specifications, as this can cause damage or malfunction. (Refer to the specifications.)

Please contact SMC when using a fluid other than compressed air. We do not guarantee against any damage if the product is used outside of the specification range.

2. The standard bowl for the air filter, filter regulator, and lubricator, as well as the sight dome for the lubricator are made of polycarbonate. Do not use in an environment where they are exposed to or come in contact with organic solvents, chemicals, cutting oil, synthetic oil, alkali, or thread lock solutions.

Effects of atmosphere of organic solvents and chemicals, and where these elements are likely to adhere to the equipment
Chemical data for substances causing degradation (Reference)

Type	Chemical name	Application examples	Material	
			Polycarbonate	Nylon
Acid	Hydrochloric acid Sulfuric acid, Phosphoric acid Chromic acid	Acid washing liquid for metals	△	×
Alkaline	Sodium hydroxide (Caustic soda) Potash Calcium hydroxide (Slack lime) Ammonia water Carbonate of soda	Degreasing of metals Industrial salts Water-soluble cutting oil	×	○
Inorganic salts	Sodium sulfide Potassium nitrate Sulfate of soda	—	×	△
Chlorine solvents	Carbon tetrachloride Chloroform Ethylene chloride Methylene chloride	Cleansing liquid for metals Printing ink Dilution	×	△
Aromatic series	Benzene Toluene Paint thinner	Coatings Dry cleaning	×	△
Ketone	Acetone Methyl ethyl ketone Cyclohexane	Photographic film Dry cleaning Textile industries	×	×
Alcohol	Ethyl alcohol IPA Methyl alcohol	Antifreeze Adhesives	△	×
Oil	Gasoline Kerosene	—	×	○
Ester	Phthalic acid dimethyl Phthalic acid diethyl Acetic acid	Synthetic oil Anti-rust additives	×	○
Ether	Methyl ether Ethyl ether	Brake oil additives	×	○
Amino	Methyl amino	Cutting oil Brake oil additives Rubber accelerator	×	×
Other	Thread-lock fluid Seawater Leak tester	—	×	△

○: Essentially safe △: Some effects may occur ×: Effects will occur

When the above factors are present, or there is some doubt, use a metal bowl for safety.

3. Do not use in such a way as to frequently fill or release the pressure from the standard bowls, such as the air filter, filter regulator, lubricator, etc. Damage to the bowl may occur. A metal bowl is recommended in these cases.

4. Please consult with SMC if the intended application calls for absolutely zero leakage, due to special atmospheric requirements, or if the use of a fluid other than air is required.

5. The mineral grease used on internal sliding parts and seals may come in contact with outlet side components. Please consult with SMC if this is not desirable.

Please contact SMC if the Safety Data Sheet (SDS) of the grease is required.

6. Do not disassemble the product or make any modifications, including additional machining.

Doing so may cause human injury and/or an accident.

Caution

1. Select a model that is suitable for the desired air cleanliness by referring to the SMC Best Pneumatics No. 6 catalog.

Mounting

Warning

1. Operation manual

Install the products and operate them only after reading the operation manual carefully and understanding its contents. Also, keep the manual where it can be referred to as necessary.

2. Ensure sufficient space for maintenance activities.

When installing the products, allow access for maintenance and inspection.

3. Tighten threads with the proper tightening torque.

When installing the products, follow the listed torque specifications.

Caution

1. To avoid reversed connections of the air inlet/outlet, make connections after confirming the “IN/OUT” marks or arrows that indicate the direction of air flow. Reversed connections can cause a malfunction.

2. Components with a bowl, e.g., an air filter, filter regulator, or lubricator, must be installed vertically with the bowl facing downward so that faulty drain discharge and dripping can be checked.

3. Ensure sufficient top, bottom, and front clearance for maintenance and operation of each component. Refer to the dimensions section for the minimum clearance of each component.



F.R.L. Units Precautions 2

Be sure to read this before handling products.

Piping

Warning

1. To screw piping material into a component, tighten with the recommended tightening torque while holding the female thread side.

If the tightening torque is insufficient, looseness or seal failure may occur. On the other hand, excess tightening torque can cause damage to the threads. Furthermore, tightening without holding the female thread side can cause damage due to the excess force that is applied directly to the piping bracket.

Recommended Tightening Torque

Unit: N·m

Connection thread	M5	1/8	1/4	3/8	1/2	3/4	1	1 1/4	1 1/2	2
Torque	1 to 1.5 ^{*1}	7 to 9	12 to 14	22 to 24	28 to 30	28 to 30	36 to 38	40 to 42	48 to 50	48 to 50

*1 After tightening by hand, use a tightening tool to tighten an additional 1/6 to 1/4 turn.

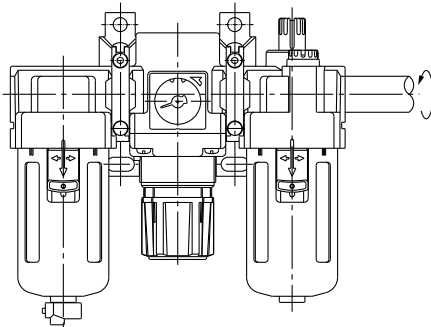

2. Avoid excessive torsional moment or bending moment other than those caused by the equipment's own weight, as this can cause damage.

Support external piping separately.

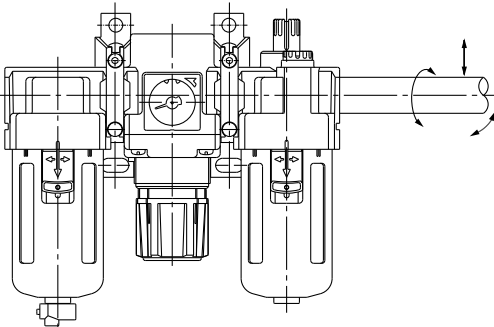

3. Piping materials without flexibility, such as steel tube piping, are prone to be affected by excess moment loads and vibrations from the piping side. Use flexible tubing in between to avoid such effects.

Caution

1. Preparation before piping

Before piping is connected, it should be thoroughly blown out with air (flushing) or washed to remove chips, cutting oil, and other debris from inside the pipe.

Caution

2. Winding of sealant tape

When screwing piping or fittings into ports, ensure that chips from the pipe threads or sealing material do not enter the piping. Also, if sealant tape is used, leave 1.5 to 2 thread ridges exposed at the end of the threads.

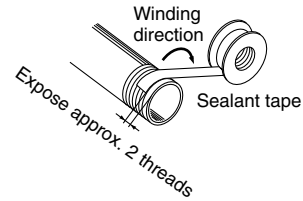

3. Refer to the Fittings and Tubing Precautions (pages 52 to 56) for handling One-touch fittings.

Air Supply

Warning

1. Type of fluids

Please consult with SMC when using the product in applications other than compressed air.

2. Take measures to ensure air quality, such as by installing an aftercooler, air dryer, or water separator.

Compressed air that contains a large amount of drainage can cause the malfunction of pneumatic equipment, such as filters, regulators, and lubricators. Therefore, take appropriate measures to ensure air quality, such as by providing an aftercooler, air dryer, or water separator.

3. Drain flushing

If condensation in the drain bowl is not emptied on a regular basis, the bowl will overflow and allow the condensation to enter the compressed air lines. This causes the malfunction of pneumatic equipment.

If the drain bowl is difficult to check and remove, the installation of a drain bowl with an auto drain option is recommended. For compressed air quality, refer to the Air Preparation Equipment Selection Guide (Best Pneumatics No. 6).

4. Use clean air.

Do not use compressed air that contains chemicals, synthetic oils that include organic solvents, salt, corrosive gases, etc., as it can cause damage or malfunction.

When synthetic oil is used for the compressor oil, depending on the type of synthetic oil used or on the conditions of use, there may be adverse effects on the resin of the pneumatic equipment or on the seals if the oil is flowed out to the outlet side. The mounting of a main line filter is recommended in such cases.



F.R.L. Units Precautions 3

Be sure to read this before handling products.

Air Supply

Caution

1. Ensure that the fluid and ambient temperatures are within the specified range.

When using at low temperatures, drain or moisture could solidify or freeze, causing damage to the seals or equipment malfunction. If the fluid temperature is less than 5°C, the moisture in the circuit could freeze, causing damage to the seals or equipment malfunction. Therefore, take appropriate measures to prevent freezing.

For compressed air quality, refer to the Air Preparation Equipment Selection Guide (Best Pneumatics No. 6).

Operating Environment

Warning

1. Do not use in an atmosphere containing corrosive gases, chemicals, sea water, water, water steam, or where there is direct contact with any of these.

Refer to each construction drawing for information on the materials of F.R.L. units.

2. Do not expose the product to direct sunlight for an extended period of time.
3. Do not use in a place subject to heavy vibration and/or shock.
4. Do not mount the product in locations where it is exposed to radiant heat.

Maintenance

Warning

1. Perform maintenance and inspection according to the procedures indicated in the operation manual.

If handled improperly, malfunction or damage of machinery and equipment may occur.

2. Maintenance work

If handled improperly, compressed air can be dangerous. Assembly, handling, repair, and element replacement of pneumatic systems should be performed by a knowledgeable and experienced person.

3. Drain flushing

Remove drainage from air filters regularly.

4. Removal of equipment, and supply/exhaust of compressed air

Before components are removed, first confirm that measures are in place to prevent workpieces from dropping, run-away equipment, etc. Then, cut off the supply pressure and electric power, and exhaust all compressed air from the system using the residual pressure release function.

When machinery is restarted, proceed with caution after confirming that appropriate measures are in place to prevent sudden movement.

5. Perform periodical inspections to detect any cracks, scratches, or other deterioration of the transparent resin bowl of the air filter, filter regulator, and lubricator or the sight dome of the lubricator.

Replace with a new bowl, sight dome, or metal bowl when any kind of deterioration is found. Otherwise, damage may occur.

6. Perform periodical inspections to detect dirt on the transparent resin bowl of the air filter, filter regulator, and lubricator or the sight dome of the lubricator.

When you find dirt on any of the above devices, clean with a mild household cleanser. Do not use other cleaning agents, as damage may occur.

Caution

1. Perform periodical inspections of the filter element and replace it as necessary. Check the element whenever the outlet pressure drops below normal or air does not flow smoothly during operation.



F.R.L. Units Precautions 4

Be sure to read this before handling products.

Regulator/Filter Regulator Design/Selection

⚠ Warning

1. Attach a safety device if damage or malfunction of equipment and devices on the outlet side may result from the output pressure exceeding the set pressure.
2. Residual pressure release (outlet pressure release) is not complete by releasing the inlet pressure. To release residual pressure, select a model with a back-flow mechanism. Using a model without a back-flow mechanism may cause unstable residual pressure release (i.e., residual pressure may or may not be released) depending on the operating conditions.
3. Please contact SMC if air will not be consumed in the system for long periods of time or if the outlet side will be used with a sealed circuit and a balanced circuit, since this may cause the set pressure of the outlet side to fluctuate.
4. Set the outlet pressure range for the regulator at 85% or less of the inlet pressure. If set above 85%, the inlet pressure will be easily affected by fluctuations in the flow rate and inlet pressure, and will become unstable.
5. Since a safety margin is calculated into the maximum regulating pressure value of the set pressure range appearing in the catalog's specification table, the set pressure may exceed the range.
6. Please contact SMC when a circuit requires the use of a regulator having relief sensitivity with high precision and setting accuracy.

⚠ Caution

1. Air consumption is 0.1 L/min. (ANR) or less under standard operation specifications. Please consult with SMC if this value is not allowable.

Mounting

⚠ Caution

1. When adjusting the pressure, unlock the knob first, and relock it after the pressure is set.

Adjustment

⚠ Warning

1. Set the regulator while confirming the displayed values of the inlet and outlet pressure gauges. Turning the knob excessively can cause damage to the internal parts.
2. Do not use a tool on the pressure regulator knob, as this can cause damage. It must be operated by hand.

Regulator/Filter Regulator Adjustment

⚠ Caution

1. Check the inlet pressure before setting.
2. The pressure gauge included with products for 0.02 to 0.2 MPa setting is for up to 0.2 MPa only. Do not apply pressure exceeding 0.2 MPa. It can damage the pressure gauge.
3. To set the pressure using the knob, turn the knob in the direction that increases pressure and lock the knob after the pressure is set. If this is done in the direction that decreases pressure, the pressure may drop from the original set pressure. Turning the knob clockwise increases the outlet pressure, and turning it counterclockwise reduces the pressure.

Lubricator

Design/Selection

⚠ Warning

1. Select a lubricator with a fixed throttle when the lubricator is used in high-frequency operations, such as in a press machine.
When selecting a model, it is necessary to select the passage area of the fixed throttle, so please consult with SMC.
2. Lubrication cannot be properly performed if the operating flow rate is too low. Select an appropriately sized lubricator by referring to the minimum dripping flow rate provided in the catalog.
3. Mount a pressure relief 3-port valve on the inlet side, and avoid the use of a lubricator that causes backflow, as this may cause damage to the internal parts.
4. Use a check valve (AKM series) to prevent the backflow of lubricant when the piping is branched at the inlet side.

Piping

⚠ Caution

1. Avoid riser piping and branch lines on the outlet side to prevent inferior lubrication.

Maintenance

⚠ Warning

1. Use class 1 turbine oil (without additives) ISO VG32. Using other lubricant can cause damage to devices or result in malfunction.
2. For the AL10, 20 type, supply the lubricant after releasing the inlet pressure, since the lubricant cannot be applied under pressurized conditions.

⚠ Caution

1. Check the usage rate once a day. If the lubricant is not normally consumed, problems may occur to the lubricated objects.



F.R.L. Units Precautions 5

Be sure to read this before handling products.

Mist Separator/Micro Mist Separator Design/Selection

⚠ Caution

1. Design the system so that a mist separator and a micro mist separator are installed where a pulsation is not likely to be generated. The pressure difference between the internal and external pressure inside the element should be kept within 0.1 MPa, since exceeding this value can cause damage.

Maintenance

⚠ Warning

1. To prevent damage to the filter element, replace it every 2 years or when the pressure drop becomes 0.1 MPa, whichever comes first.
2. Release the accumulated condensation inside air filter bowls periodically and before the accumulation reaches the maximum capacity. If accumulated condensation flows out to the outlet side, it can cause a malfunction.

Air Filter Maintenance

⚠ Warning

1. To prevent damage to the element, replace the element every 2 years or when the pressure drop becomes 0.1 MPa, whichever comes first.
2. Release the accumulated condensation inside air filter bowls periodically and before the accumulation reaches the maximum capacity. If accumulated condensation flows out to the outlet side, it can cause a malfunction.

Air Combination Design/Selection

⚠ Caution

1. When using a 2-unit combination, such as the AC□0A, AC□0B, or AC□0D, secure the top and bottom of the bracket. For a 3-unit, securing the bottom side of the bracket is recommended.
2. The bracket position varies depending on the attachment (T-spacer or pressure switch) mounting.
3. The standard mounting position for a bracket is on the OUT side of each component (the AF, AR, AL, AW, and AFM). For the standard mounting position dimensions for brackets for mounting attachments, refer to Best Pneumatics No. 6.
4. A bracket cannot be mounted on both sides of a T-spacer or a pressure switch.
5. Please contact SMC if you wish to change the bracket mounting position.

Float Type Auto Drain Design/Selection

⚠ Warning

1. Use an auto drain under the following conditions to avoid malfunction.

<N.O. type>

- Operating compressor: 0.75 kW (100 L/min. (ANR)) or more
When using 2 or more auto drains, multiply the above value by the number of auto drains to find the minimum capacity of the required compressors.
Selecting a model with a minimum or larger required capacity is recommended. For example, when using 2 auto drains, a compressor capacity of at least 1.5 kW (200 L/min. (ANR)) is required.
- Operating pressure: 0.1 MPa or more

<N.C. type>

- Operating pressure for AD17/27: 0.1 MPa or more
Operating pressure for AD37/47: 0.15 MPa or more

Piping

⚠ Caution

1. Float type auto drain

Drain piping should be performed under the following conditions to avoid malfunction.

<N.O. type>

- Use piping whose I.D. is $\phi 6.5$ or larger, and whose length is 5 m or less. Avoid riser piping.

<N.C. type>

- AD17/27: Use piping with an I.D. of $\phi 2.5$ or larger.
AD37/47: Use piping with an I.D. of $\phi 4$ or larger.
Length is 5 m or less. Avoid riser piping.

Maintenance

⚠ Caution

1. Turn the knob counterclockwise to release the drainage manually. Avoid applying excessive torque to the knob, such as by using a tool, as this can damage the auto drain.

After releasing the condensation, turn the knob clockwise until it stops.

2. Air leakage or other performance malfunctions can occur if premature clogging of the element or pressure drop causes the pressure inside the bowl to deviate from the specified pressure range parameters.

Check the pressure whenever such an irregularity occurs.