



3/4/5-Port Solenoid Valves Precautions 1

Be sure to read this before handling products.

Design/Selection

Warning

1. Confirm the specifications.

Products represented in this catalog are designed only for use in compressed air systems (including vacuum).

Do not operate at pressures, temperatures, etc., beyond the range of specifications, as this can cause damage or malfunction. (Refer to the specifications.)

Please contact SMC when using a fluid other than compressed air (including vacuum).

We do not guarantee against any damage if the product is used outside of the specification range.

2. Actuator drive

When an actuator, such as a cylinder, is to be driven using a valve, take appropriate measures (such as the installation of a cover or the restricting of access to the product) to prevent potential danger caused by actuator operation.

3. Intermediate stops

For the 3-position closed center or double check valve types, it is difficult to make the piston stop at the required position accurately due to the compressibility of air.

Furthermore, since valves and cylinders are not guaranteed for zero air leakage, it may not be possible to hold a stopped position for an extended period of time.

Please contact SMC if it is necessary to hold a stopped position for an extended period of time.

4. Effects of back pressure when using a manifold

Use caution when valves are used on a manifold because actuators may malfunction due to back pressure.

Especially when using a 3-position exhaust center valve, a double check valve, or a single acting cylinder, take appropriate measures to prevent malfunction by using it with an individual EXH spacer assembly, a back pressure check valve, or an individual exhaust manifold.

Also, since the SQ1000 4-position dual 3-port valve is a 4-port valve specification (R1 and R2 are common), one back pressure check valve can be installed. As a result, back pressure from valves in other stations can be prevented, but back pressure inside this valve cannot be prevented.

5. Holding pressure (including vacuum)

Since valves are subject to air leakage, they cannot be used for applications such as holding pressure (including vacuum) in a pressure vessel.

6. Not suitable for use as an emergency shut-off valve, etc.

The valves listed in this catalog are not designed for safety applications such as an emergency shutoff valve. If the valves are used in such applications, additional safety measures should be adopted.

7. Release of residual pressure

For maintenance and inspection purposes install a system for releasing residual pressure. Especially in the case of the 3-position closed center valve or double check valve types, ensure that the residual pressure between the valve and the cylinder is released.

8. Operation in a vacuum condition

When a valve is used for switching a vacuum, take measures to install a suction filter or similar to prevent external dust or other foreign matter from entering inside the valve.

In addition, at the time of vacuum adsorption, be sure to supply a constant supply of vacuum. Failure to do so may result in foreign matter sticking to the adsorption pad or air leakage, causing the workpiece to drop.

9. Regarding vacuum switch valves and vacuum release valves

If a non-vacuum valve is installed in the middle of a piping system that contains a vacuum, the vacuum condition will not be maintained. Use a valve designed for use under vacuum conditions.

10. Double solenoid type

When using the double solenoid type for the first time, actuators may travel in an unexpected direction depending on the switching position of the valve. Implement measures to prevent any danger from occurring when operating the actuator.

11. Ventilation

Provide ventilation when using a valve in a confined area, such as in a closed control panel. For example, install a ventilation opening, etc., in order to prevent pressure from increasing inside of the confined area and to release the heat generated by the valve.

12. Extended periods of continuous energization

● If a valve will be continuously energized for an extended period of time, the temperature of the valve will increase due to the heat generated by the coil assembly. This will likely adversely affect the performance of the valve and any nearby peripheral equipment. Therefore, if the valve is to be energized for periods of longer than 30 minutes at a time or if during the hours of operation the energized period per day is longer than the de-energized period, we advise using a valve with specifications listed below.

- Pilot operated: A 0.4 W or lower valve, such as the SY series, or a valve with a power-saving circuit
- Direct operated: A continuous duty type valve such as the VK series or the VT series

If conflicting instructions are given in the "Specific Product Precautions" or on the "How to Order Valves" page, give them priority.

13. Do not disassemble the product or make any modifications, including additional machining.

Doing so may cause human injury and/or an accident.



3/4/5-Port Solenoid Valves Precautions 2

Be sure to read this before handling products.

Design/Selection

Warning

Latching Type [VQ/SQ series double (latching) type]

The latching solenoid is equipped with a self-holding mechanism which permits the movable iron core in the solenoid to hold the set position or reset position during momentary energization (20 ms or longer), so there is no need for continuous energization. Depending on conditions, continuous energization may cause a rise in the coil temperatures, resulting in a malfunction.

<Special precautions to be taken with the latching type>

1) Do not continuously energize the latching type.

When it is necessary to energize it continuously, keep the energized period to 10 minutes or less, and then leave a de-energized period (on both the A side and B side) lasting longer than the energized period, before operating it again. The duty ratio should be 50% or less.

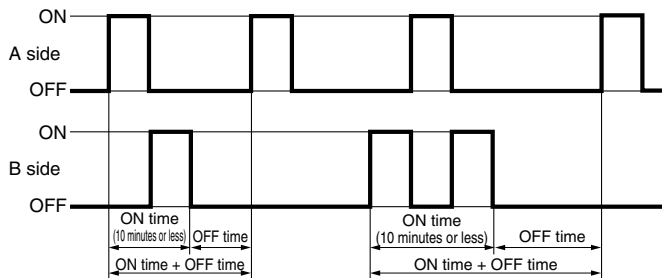

- Maximum ON time is 10 minutes.

- Duty ratio $\leq 50\%$ (Duty ratio = $\frac{\text{ON time}}{\text{ON time} + \text{OFF time}}$)

Example: When energization lasts for five minutes, it should be followed by five or more minutes of de-energization. Because the latching type has only one solenoid, both the A side and B side should be off for five minutes or more.

However, a minimum energization time of 20 ms is recommended.

[Ambient temperature]

The product should be installed in an environment with an ambient temperature of -10° to 50°C . Especially in environments with poor heat dissipation, such as in a panel, the heat of the coil can cause the ambient temperature to rise, so please exercise caution.

- 2) Use a circuit in which the set and reset signals will not be energized at the same time.
- 3) The minimum energization time for self-holding is 20 ms.
- 4) Even when there is no problem with normal operations and locations, please consult with SMC before using in locations with a vibration of 30 m/s^2 or more or a strong magnetic field.
- 5) Even though this valve is set to the reset position at the time of shipment (passage: A \rightarrow R), it may switch to the set position during transportation or due to impact when mounting valves, etc. Therefore, check the initial position with the power supply or by performing a manual override prior to use.

Latching	Passage	Indicator light
A-C ON (set)	P \rightarrow A	Orange
B-C ON (reset)	A \rightarrow R	Green

Single	Passage	Indicator light
A-C ON	P \rightarrow A	Orange
OFF	A \rightarrow R	—

Caution

1. Precautions for 2-position double solenoid valves

If a double solenoid valve is operated with momentary energization, it should be energized for at least 0.1 seconds. However, depending on the piping conditions, the cylinder may malfunction even when the double solenoid valve is energized for 0.1 seconds or longer. In this case, energize the double solenoid valve until the cylinder is exhausted completely.

2. Leakage voltage

Take note that the leakage voltage will increase when a resistor is used in parallel with a switching element or when a C-R circuit (surge voltage suppressor) is used for protecting a switching device because of the leakage voltage passing through the C-R circuit. The suppressor residual leakage voltage should be as follows.

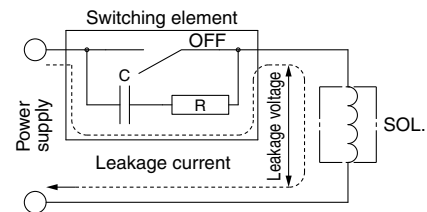

DC coil

- SV, SY, SYJ, SX, SZ, SJ, VV061 (V060), VQ (V100), VQC (V100), SQ (V100), VQZ, VF, VFR, VFS, VP7, VS7, VP300, VP500, VP700, VT307, VG342 } 3% or less of the rated voltage
- VQD, VZ, VZS, VK, VT317, VT325 } 2% or less of the rated voltage
- VT301, VT315, VP31□5, VP4□50, VP4□70 } 5% or less of the rated voltage

AC coil

- VK, VFR, VFS, VP7, VS7, VT317 } 20% or less of the rated voltage
- VZ, VZS, VT307, VG342, VT301, VT315, VT325, VP31□5, VT4□50, VP4□70 } 15% or less of the rated voltage
- SY, SYJ, VQZ, VF, VP300, VP500, VP700, VQ (V100) } 8% or less of the rated voltage

3. Valves with a power-saving circuit (PWM circuit built-in type)

Valves with a power-saving circuit (PWM circuit built-in type) perform the high-speed switching operation with the PWM control circuit inside the valve after the rated power has been applied for several tens of ms to reduce the power consumption. The problems shown below may occur in this type of valve due to the switch or drive circuit system by the PWM control. Be sure to check the operation with the customer's machine sufficiently when selecting the product.

1) The valve does not turn ON.

1. If the PWM circuit built-in type valve is driven by a mechanical relay, etc., and chattering occurs during the several tens of ms necessary for the valve to reach its rated voltage, the valve may not turn ON correctly.
2. If a filter, etc., is connected between the power supply and the PWM circuit built-in type valve, the current necessary to drive the valve lowers due to the effects of the filter, and then the valve may not turn ON correctly.



3/4/5-Port Solenoid Valves Precautions 3

Be sure to read this before handling products.

Design/Selection

Caution

- The valve does not turn OFF.
If the PWM circuit built-in type valve is driven by the photo coupler, the photo coupler cannot turn OFF and the valve is kept in an ON state. Therefore, take great care when using the photo coupler built-in SSR (solid state relay) or drive circuit.

Applicable solenoid valve series with power-saving circuit

- SY (High pressure type), VF, VP
- VQ100, VQD1000, S070

4. Solenoid valve drive for AC with a solid state output (SSR, TRIAC output, etc.)

- Current leakage**
When using a snubber circuit (C-R element) for surge protection of the output, a very small amount of electrical current will continue to flow even during the OFF state. This results in the valve not returning. In a situation where the tolerance is exceeded, as in the above case, take measures to install a bleeder resistor.
- Minimum allowable load amount (Min. load current)**
When the consumption current of a valve is less than the output's minimum allowable load volume or the margin is small, the output may not switch normally. Please contact SMC.
- Solenoid valve with full wave rectifier circuit**
When the solenoid valve built-in full wave rectifier circuit with AC specifications is used, a return failure of the solenoid valve may occur depending on the kind of triac output circuit. Carefully check this point when selecting a SSR or sequencer.
For details, contact the SSR or sequencer manufacturer.

5. Surge voltage suppressor

- The surge voltage suppressor built into the valve is intended to protect the output contacts so that the surge generated inside valve does not adversely affect the output contacts. Therefore, if an overvoltage or overcurrent is received from an external peripheral device, the surge voltage protection element inside the valve is overloaded, causing the element to break. In the worst case, the breakage causes the electric circuit to enter short-circuit status. If energizing continues while in this state, a large current flows. This may cause secondary damage to the output circuit, external peripheral device, or valve, and may also cause a fire. So, take appropriate protective measures, such as the installation of an overcurrent protection circuit in the power supply or a drive circuit to maintain a sufficient level of safety.
- If a surge protection circuit contains nonstandard diodes, such as Zener diodes or varistor, a residual voltage that is in proportion to the protective circuit and the rated voltage will remain. Therefore, take into consideration the surge voltage protection of the controller.
In the case of diodes, the residual voltage is approximately 1 V.

6. Surge voltage intrusion

Applicable series (non-polar type solenoid valves)

VQ100 and 3/4/5-port solenoid valves VQ(C), VQZ, VQD (2 W type) series

SY100, V100, and 3/4/5-port solenoid valves SY, SYJ, SX, SZ, SV, SJ, VF, VP series

With non-polar type solenoid valves, at times of sudden interruption of the loading power supply, such as emergency shutdown, surge voltage intrusion may be generated from loading equipment with a large capacity (power consumption), and a solenoid valve in a de-energized state may switch over (see Figure 1).

When installing a breaker circuit for the loading power supply, consider using a solenoid valve with polarity (with polarity protection diode), or install a surge absorption diode between the loading equipment COM line and the output equipment COM line (see Figure 2).

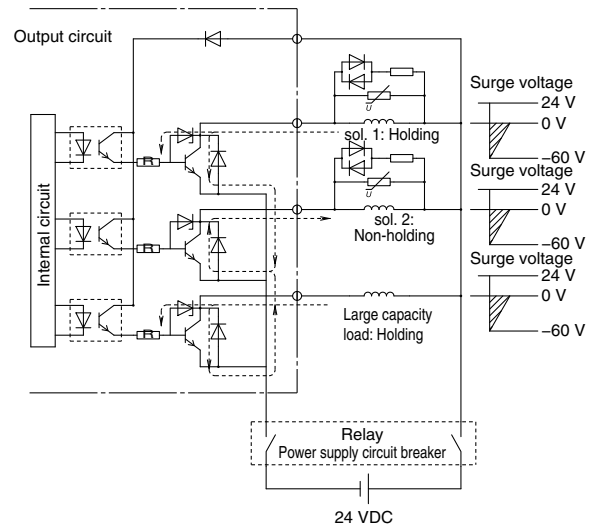

Figure 1. Surge intrusion circuit example (NPN outlet example)

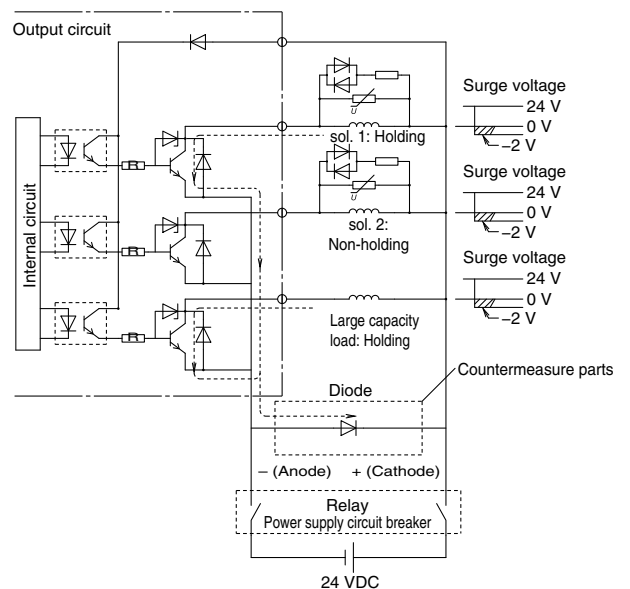

Figure 2. Surge intrusion countermeasure example (NPN outlet example)



3/4/5-Port Solenoid Valves Precautions 4

Be sure to read this before handling products.

Design/Selection

⚠ Caution

7. Operation in low temperature conditions

It is possible to operate a valve in extreme temperatures, as low as -10°C . Take appropriate measures to avoid the freezing of drainage, moisture, etc., in low temperatures.

8. Operation for air blowing

When using a solenoid valve for air blowing, use an external pilot type.

Use caution because the pressure drop caused by the air blowing can have an effect on the internal pilot type valve when internal pilot type valves and external pilot type valves are used on the same manifold.

Additionally, when compressed air within the pressure range of the established specifications is supplied to the external pilot type valve's port, and a double solenoid valve is used for air blowing, the solenoids should be energized when air is being blown.

9. Mounting orientation

Rubber seal: Refer to the specifications of each series. Please consult with SMC for models not indicated in the specification column.

Metal seal: The mounting orientation of a single solenoid is universal. No specific orientation is necessary. When installing a double solenoid or a 3-position configuration, mount the valve so that the spool valve is horizontal.

10. Initial lubrication of main valve

The following initial lubricant has already been applied to the main valve.

- **Rubber seal, spool valve: Grease**
Please consult with SMC, as there are some standard valve products that use fluorine grease for food processing equipment (NSF H-1).
- **Metal seal, spool valve: Turbine oil**
Turbine oil is applied to the spool valve of the metal seal type. Therefore, turbine oil may seep out when a new product is delivered or while the valve is in storage.

11. For the pilot EXH (PE) port

If the solenoid valve and the manifold's pilot EXH (PE) port is restricted extremely or blocked, abnormal operation of the solenoid valve may occur.

Mounting

⚠ Warning

1. Operation manual

Install the products and operate them only after reading the operation manual carefully and understanding its contents. Also, keep the manual where it can be referred to as necessary.

2. Ensure sufficient space for maintenance activities.

When installing the products, allow access for maintenance and inspection.

3. Tighten threads with the proper tightening torque.

When installing the products, follow the listed torque specifications.

4. If air leakage increases or equipment does not operate properly, stop operation.

Check mounting conditions when air and power supplies are connected. Initial function and leakage tests should be performed after installation.

5. Painting and coating

Warnings or specifications printed on or affixed to the product should not be erased, removed, or covered up.

Please consult with SMC before applying paint to resinous parts, as this may have an adverse effect due to the solvent in the paint.

Piping

⚠ Caution

1. Refer to the Fittings and Tubing Precautions (pages 52 to 56) for handling One-touch fittings.

2. Preparation before piping

Before piping is connected, it should be thoroughly blown out with air (flushing) or washed to remove chips, cutting oil, and other debris from inside the pipe.

3. Winding of sealant tape

When screwing piping or fittings into ports, ensure that chips from the pipe threads or sealing material do not enter the piping. Also, if sealant tape is used, leave 1 thread ridge exposed at the end of the threads.

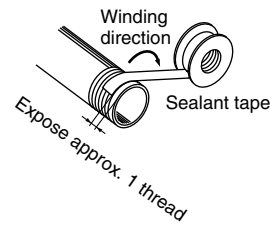

4. Closed center and double check valve types

For the closed center or double check valve types, check the piping to prevent air leakage from the piping between the valve and the cylinder.

5. Connection of piping and fittings

When screwing piping or fittings into the valve, tighten them as follows.

1) When using SMC's M3, M5, M6, or 10-32UNF fittings, follow the procedures below to tighten them.

• Connection thread: M3

First, tighten by hand, then use a suitable wrench to tighten the hexagonal portion of the body an additional $1/4$ turn. The reference value for the tightening torque is 0.4 to 0.5 N·m.

• Connection thread: M5 and 10-32UNF

First, tighten by hand, then use a suitable wrench to tighten the hexagonal portion of the body an additional $1/6$ to $1/4$ turn. The reference value for the tightening torque is 1 to 1.5 N·m.

• M6

First, tighten by hand, then use a suitable wrench to tighten the hexagonal portion of the body an additional $1/6$ to $1/4$ turn.

* Excessive tightening may damage the thread portion or deform the gasket and cause air leakage. Insufficient tightening may loosen the threads or cause air leakage.

• When using a fitting other than an SMC fitting, follow the instructions given by the fitting manufacturer.

2) For a fitting with sealant R or NPT, first, tighten it by hand, then use a suitable wrench to tighten the hexagonal portion of the body an additional two or three turns. For the tightening torque, refer to the table below.

Connection thread size (R, NPT)	Proper tightening torque (N·m)
$1/8$	3 to 5
$1/4$	8 to 12
$3/8$	15 to 20
$1/2$	20 to 25
$3/4$	28 to 30
1	36 to 38
$1\ 1/4$	40 to 42
$1\ 1/2$	48 to 50
2	48 to 50



3/4/5-Port Solenoid Valves Precautions 5

Be sure to read this before handling products.

Piping

⚠ Caution

- 3) If the fitting is tightened with excessive torque, a large amount of sealant will seep out. Remove the excess sealant.
- 4) Insufficient tightening may cause seal failure or loosen the threads.
- 5) For reuse
 - (1) Normally, fittings with a sealant can be reused up to 2 to 3 times.
 - (2) To prevent air leakage through the sealant, remove any loose sealant stuck to the fitting by blowing air over the threaded portion.
 - (3) If the sealant no longer provides effective sealing, wind sealing tape over the sealant before reusing. Do not use any form of sealant other than the tape type of sealant.
 - (4) Once the fitting has been tightened, backing it out to its original position often causes the sealant to become defective. Air leakage will occur.

6. Uni thread fittings

- 1) First, tighten the threaded portion by hand, then use a suitable wrench to tighten the hexagonal portion of the body further at wrench tightening angle shown below. For the reference value for the tightening torque, refer to the table below.

Connection Female Thread: Rc, NPT, NPTF

Uni thread size	Wrench tightening angle after tightened by hand (deg)	Tightening torque (N·m)
1/8	30 to 60	3 to 5
1/4	30 to 60	8 to 12
3/8	15 to 45	14 to 16
1/2	15 to 30	20 to 22

Connection Female Thread: G

Uni thread size	Wrench tightening angle after tightened by hand (deg)	Tightening torque (N·m)
1/8	30 to 45	3 to 4
1/4	15 to 30	4 to 5
3/8	15 to 30	8 to 9
1/2	15 to 30	14 to 15

- 2) The gasket can be reused up to 6 to 10 times. It can be replaced easily when it has sustained damage. A broken gasket can be removed by holding it and then turning it in the same direction as loosening the thread. If the gasket is difficult to remove, cut it with nippers, etc. In such a case, use caution not to scratch the seat face because the seat face of the fitting's 45° gasket is the sealing face.

7. Piping to products

When piping to a product, refer to the operation manual to avoid mistakes regarding the supply port, etc.

Wiring

⚠ Warning

1. **The solenoid valve is an electrical product. For safety, install an appropriate fuse and circuit breaker before use.**

⚠ Caution

1. Polarity

When connecting power to a solenoid valve with a DC specification and a light or surge voltage suppressor, check for polarity.

If there is polarity, take note of the following.

Without diode to protect polarity:

If a mistake is made regarding the polarity, damage may occur to the diode in the valve, the switching element in the control device, power supply equipment, etc.

With diode to protect polarity:

If the polarity connection is wrong, the valve will not operate.

2. Applied voltage

When electric power is connected to a solenoid valve, be careful to apply the proper voltage. Improper voltage may cause malfunction or coil damage.

3. Check the connections.

Check if the connections are correct after completing all wiring.

4. External force applied to the lead wire

If an excessive force is applied to the lead wire, this may cause faulty wiring. Take appropriate measures so that a force of 30 N or more is not applied to the lead wire.

When instructions are given in the Specific Product Precautions, follow these specifications.



3/4/5-Port Solenoid Valves Precautions 6

Be sure to read this before handling products.

Lubrication

Warning

1. Lubrication

[Rubber seal]

- 1) All valves except those listed below have been lubricated for life by the manufacturer and therefore do not require lubrication while in service.

Valves requiring lubrication

VP4□50, VP4□70, VP31□5, VPA4□50, VPA4□70, VPA31□5

- 2) If a lubricant is used in the system, use class 1 turbine oil (no additives), ISO VG32. For details about lubricant manufacturers' brands, refer to the SMC website. Additionally, please contact SMC for details about class 2 turbine oil (with additives) ISO VG32.
Once lubricant is utilized within the system, since the original lubricant applied within the product during manufacturing will be washed away, please continue to supply lubrication to the system. Without continued lubrication, malfunctions could occur.
If turbine oil is used, refer to the Safety Data Sheet (SDS) of the oil.

[Metal seal]

- 1) These valves can be used without lubrication.
- 2) If a lubricant is used in the system, use class 1 turbine oil (no additives), ISO VG32. For details about lubricant manufacturers' brands, refer to the SMC website. Additionally, please contact SMC for details about class 2 turbine oil (with additives) ISO VG32.

2. Lubrication amount

If the lubrication amount is excessive, the oil may accumulate inside the pilot valve, causing malfunction or response delay. So, do not apply a large amount of oil. When a large amount of oil needs to be applied, use an external pilot type to put the supply air on the pilot valve side in the non-lube state. This prevents the accumulation of oil inside the pilot valve.

Air Supply

Warning

1. Type of fluids

Please consult with SMC when using the product in applications other than compressed air.

2. When there is a large amount of drainage

Compressed air containing a large amount of drainage can cause the malfunction of pneumatic equipment. An air dryer or water separator should be installed upstream from filters.

3. Drain flushing

If condensation in the drain bowl is not emptied on a regular basis, the bowl will overflow. This may cause the malfunction of pneumatic equipment.

If the drain bowl is difficult to check and remove, the installation of a drain bowl with an auto drain option is recommended.

For compressed air quality, refer to the SMC Best Pneumatics No. 6 catalog.

4. Use clean air.

Do not use compressed air that contains chemicals, synthetic oils that include organic solvents, salt, corrosive gases, etc., as it can cause damage or malfunction.

Caution

1. When extremely dry air is used as the fluid, degradation of the lubrication properties inside the equipment may occur, resulting in reduced reliability (or reduced service life) of the equipment. Please consult with SMC.

2. Install an air filter.

Install an air filter upstream near the valve. Select an air filter with a filtration size of 5 μm or smaller.

3. Take measures to ensure air quality, such as by installing an aftercooler, air dryer, or water separator.

Compressed air that contains a large amount of drainage can cause the malfunction of pneumatic equipment, such as valves. Therefore, take appropriate measures to ensure air quality, such as by providing an aftercooler, air dryer, or water separator.

4. If an excessive amount of carbon powder is present, install a mist separator on the upstream side of the valve.

If excessive carbon dust is generated by the compressor, it may adhere to the inside of a valve and cause it to malfunction.

For compressed air quality, refer to the SMC Best Pneumatics No. 6 catalog.



3/4/5-Port Solenoid Valves Precautions 7

Be sure to read this before handling products.

Operating Environment

Warning

1. Do not use in an atmosphere containing corrosive gases, chemicals, sea water, water, water steam, or where there is direct contact with any of these.
2. Products with IP65 and IP67 enclosures (based on IEC60529) are protected against dust and water. However, these products cannot be used in water.
3. Products compliant with IP65 and IP67 satisfy the product specifications when mounted properly. Be sure to read the precautions for each product.
4. Do not use in an environment where flammable gas or explosive gas exists. Usage may cause a fire or explosion. The products do not have an explosion proof construction.
5. Do not use in a place subject to heavy vibration and/or shock.
6. The valve should not be exposed to prolonged sunlight. Use a protective cover. Note that the valve is not for outdoor use.
7. Remove any sources of excessive heat.
8. If it is used in an environment where there is possible contact with oil, weld spatter, etc., exercise preventive measures.
9. When the solenoid valve is mounted in a control panel or it's energized for a long period of time, make sure the ambient temperature is within the specifications of the valve.

Caution

1. **Temperature of ambient environment**
Use the valve within the range of the ambient temperature specification of each valve. In addition, pay attention when using the valve in environments where the temperature changes drastically.
2. **Humidity of ambient environment**
 - When using the valve in environments with low humidity, take measures to prevent static.
 - If the humidity rises, take measures to prevent the adhesion of water droplets on the valve.

Maintenance

Warning

1. **Perform maintenance and inspection according to the procedures indicated in the operation manual.**
If handled improperly, human injury and/or malfunction or damage of machinery and equipment may occur.
2. **Removal of equipment, and supply/exhaust of compressed air**
Before components are removed, first confirm that measures are in place to prevent workpieces from dropping, run-away equipment, etc. Then, cut off the supply air and electric power, and exhaust all air pressure from the system using the residual pressure release function.
For the 3-position closed center or double check valve types, exhaust the residual pressure between the valve and the cylinder.
When the equipment is operated after remounting or replacement, first confirm that measures are in place to prevent the lurching of actuators, etc. Then, confirm that the equipment is operating normally.
In particular, when a 2-position double solenoid valve is used, releasing residual pressure rapidly may cause the spool valve to malfunction, depending on the piping conditions, or the connected actuator to operate.
3. **Low-frequency operation**
Valves should be operated at least once every 30 days to prevent malfunction. (Use caution regarding the air supply.)
4. **Manual override**
When a manual override is operated, connected equipment will be actuated.
Operate only after safety is confirmed.
5. **If the volume of air leakage increases or the valve does not operate normally, do not use the valve.**
Perform periodic maintenance on the valve to confirm the operating condition and check for any air leakage.

Caution

1. **Drain flushing**
Remove drainage from the air filters regularly.
2. **Lubrication**
In the case of rubber seals, once lubrication has been started, it must be continued.
Use class 1 turbine oil (with no additives), VG32. If other lubricant oil is used, it may cause a malfunction. Please contact SMC for information on the suggested class 2 turbine oil (with additives), VG32.
3. **Manual override operation**
When switching a double solenoid valve via the manual override operation, instantaneous operation may cause the malfunction of the cylinder. It is recommended that the manual override be held until the cylinder reaches the stroke end position.