

CY1S-Z Series

ø6, ø10, ø15
ø20, ø25
ø32, ø40



Construction

CY1S: Bilateral piping type

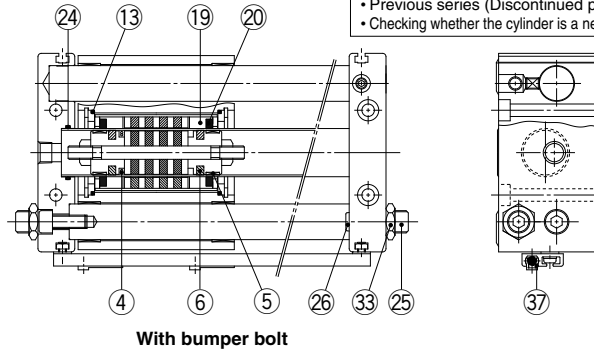

The products in this series are refreshed products. Check the following before ordering.
 • Previous series (Discontinued product) CY1S → p. 140
 • Checking whether the cylinder is a new or a previous model → p. 563, 564

With bumper bolt

CY1SG: Centralized piping type

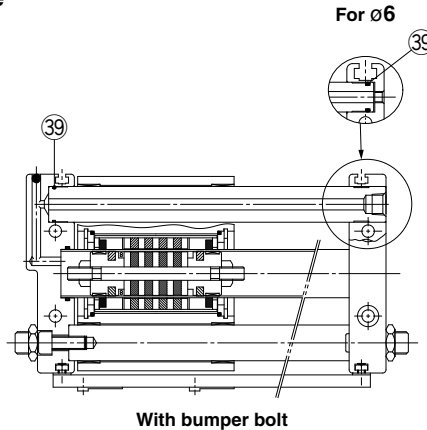

With bumper bolt

* The numbers correspond with those in the "Construction" of the CY1S-Z series in the Best Pneumatics catalog.

Seal Kit List

No.	Description	Material	Note
④	Piston seal	NBR	
⑤	Wear ring A	Special resin	
⑥	Lube-retainer A	Special resin	
⑬	Slider gasket	NBR	
⑱	Wear ring B	Special resin	
⑳	Lube-retainer B	Special resin	

No.	Description	Material	Note
⑳	Cylinder tube gasket	NBR	
㉕	Bumper bolt	Chromium molybdenum steel	
㉖	Bumper	Urethane rubber	
㉓	Hexagon nut	Chromium molybdenum steel	
㉗	Switch spacer	Special resin	
㉙	Guide shaft gasket	NBR	

Replacement Parts: Seal Kit

Bore size (mm)	Seal kit		Bumper bolt assembly		Switch spacer	
	Part no.	Contents	Part no.	Contents	Part no.	Contents
6	CY1S6-Z-PS	Set of nos. ④, ⑤, ⑬, ⑱, ㉔, ㉙	CYS06-37-AJ024-R	Set of nos. ㉕, ㉖, ㉓	BMY3-016	No. ㉗
10	CY1S10-Z-PS	Set of nos. ④, ⑬, ⑱, ㉔, ㉙	CYS10-37-AJ025-R			
15	CY1S15-Z-PS	Set of nos. ④, ⑤, ⑥, ⑬, ⑱, ㉔, ㉙	CYS20-37-AJ027-R			
20	CY1S20-Z-PS		CYS25-37-AJ028-R			
25	CY1S25-Z-PS		CYS32-37-AJ029-R			
32	CY1S32-Z-PS					
40	CY1S40-Z-PS					

Note 1) The seal kit includes ④, ⑤, ⑬, ⑱, ㉔, ㉙ for ø6. ④, ⑬, ⑱, ㉔, ㉙ for ø10. ④, ⑤, ⑥, ⑬, ⑱, ㉔, ㉙ are for ø15 to ø40. Order the seal kit based on each bore size.

Note 2) The seal kit includes a grease pack (10 g). Order with the following part number when only the grease pack is required.
Grease pack part no.: GR-S-010

Note 3) A switch spacer, as specified in the table above will be required if an auto switch is mounted afterward.
 When ordering an additional auto switch, also order an additional switch spacer.
 Refer to "Auto Switch Mounting" for details.