

CXS Series

ø6, ø10, ø15, ø20, ø25, ø32



Construction

CXSM6

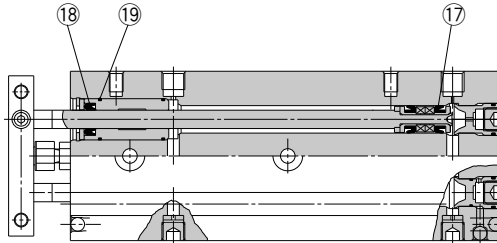

CXSM10 to 32

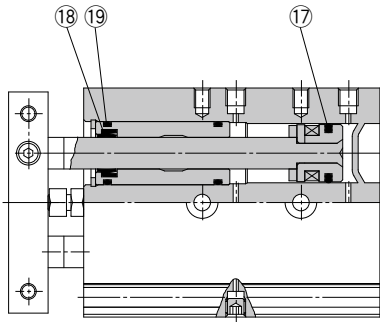

* The numbers correspond with those in the "Construction" of the CXS series in the Best Pneumatics catalog.

Seal Kit List

No.	Description	Material	Note
17	Piston seal	NBR	
18	Rod seal		
19	O-ring		

Replacement Parts: Seal Kit

Bore size (mm)	Part no.	Contents
6	CXSM6-PS	Set of nos. 17, 18, 19
10	CXSM10APS	
15	CXSM15-PS	
20	CXSM20-PS	
25	CXSM25-PS	
32	CXSM32-PS	

* The seal kit includes 17, 18 and 19. Order the seal kit based on each bore size.

* Since the seal kit does not include a grease pack, it should be ordered separately.

Grease pack part no.: GR-S-010 (10 g)

Actuators

Modular F.R.L.
Pressure Control Equipment

Air Preparation
Equipment

Industrial Filters

Replacement
Procedure

Actuators

Modular F.R.L.
Pressure Control Equipment

Industrial Filters

Dual Rod Cylinder/Basic Type: Ball Bushing Bearing

CXS Series

ø6, ø10, ø15, ø20, ø25, ø32



Construction

CXSL6

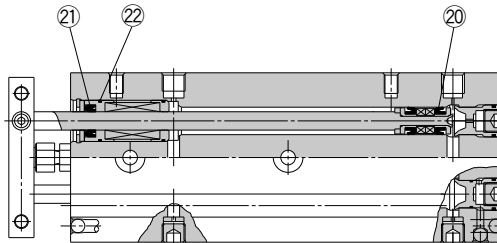

CXSL10 to 32

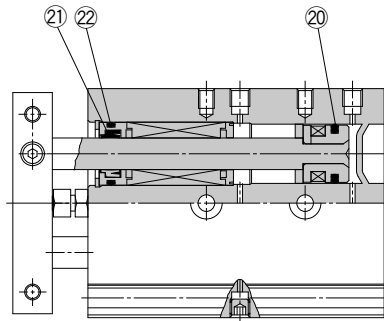

* The numbers correspond with those in the "Construction" of the CXS series in the Best Pneumatics catalog.

Seal Kit List

No.	Description	Material	Note
②①	Piston seal	NBR	
②①	Rod seal		
②②	O-ring		

Replacement Parts: Seal Kit

Bore size (mm)	Part no.	Contents
6	CXSL6-PS	Set of nos. ②①, ②②
10	CXSL10BPS	
15	CXSL15APS	
20	CXSL20APS	
25	CXSL25APS	
32	CXSL32APS	

* The seal kit includes ②①, ②① and ②②. Order the seal kit based on each bore size.

* Since the seal kit does not include a grease pack, it should be ordered separately.

Grease pack part no.: GR-S-010 (10 g)

Dual Rod Cylinder/With Air Cushion

CXS Series

ø20, ø25, ø32

The Replacement Procedure is on p. 372

Construction

CXSM/With air cushion

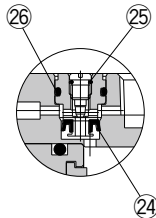
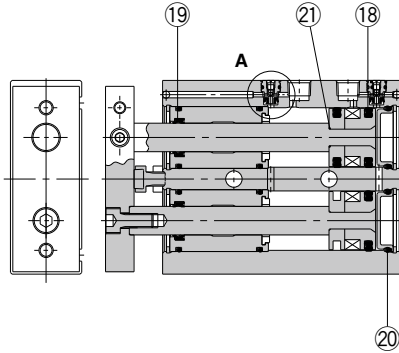

Close-up of A

CXSL/With air cushion

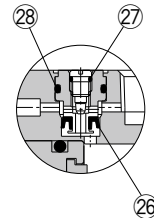
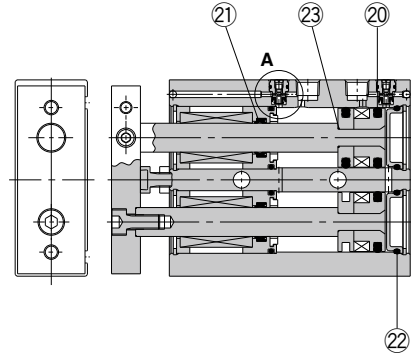

Close-up of A

* The numbers correspond with those in the "Construction" of the CXS series in the Best Pneumatics catalog.

Seal Kit List (CXSM)

No.	Description	Material	Note
18	Piston seal	NBR	21 and 24 to 26 are non-replaceable parts, so they are not included in the seal kit.
19	Rod seal		
20	O-ring		
21	O-ring		
24	Check seal		
25	Needle gasket		
26	Check gasket		

Replacement Parts: Seal Kit (CXSM)

Bore size (mm)	Part no.	Contents
20	CXSM20A-PS	Set of nos. 18, 19, 20
25	CXSM25A-PS	
32	CXSM32A-PS	

- * The seal kit includes 18, 19 and 20. Order the seal kit based on each bore size.
- * Since the seal kit does not include a grease pack, it should be ordered separately.

Grease pack part no.: GR-S-010 (10 g)

Seal Kit List (CXSL)

No.	Description	Material	Note
20	Piston seal	NBR	23 and 26 to 28 are non-replaceable parts, so they are not included in the seal kit.
21	Rod seal		
22	O-ring		
23	O-ring		
26	Check seal		
27	Needle gasket		
28	Check gasket		

Replacement Parts: Seal Kit (CXSL)

Bore size (mm)	Part no.	Contents
20	CXSL20A-PS	Set of nos. 20, 21, 22
25	CXSL25A-PS	
32	CXSL32A-PS	

- * The seal kit includes 20, 21 and 22. Order the seal kit based on each bore size.
- * Since the seal kit does not include a grease pack, it should be ordered separately.

Grease pack part no.: GR-S-010 (10 g)

Actuators

Modular F.R.L.
Pressure Control Equipment

Air Preparation
Equipment

Industrial Filters

Replacement
Procedure

Actuators

Modular F.R.L.
Pressure Control Equipment

Industrial Filters

Dual Rod Cylinder/With End Lock for Retraction Side

CXS Series

ø6, ø10, ø15, ø20, ø25, ø32



Construction

CXSM6

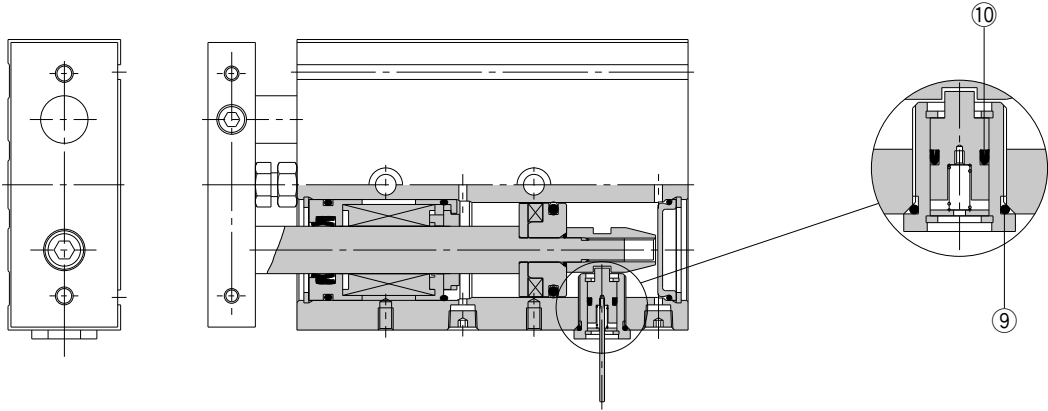

* The numbers correspond with those in the "Construction" of the CXS series in the Best Pneumatics catalog.

Seal Kit List

No.	Description	Material	Note
⑨	O-ring	NBR	
⑩	Rod seal		

Replacement Parts: Seal Kit

Bore size (mm)	Part no.	Contents
6	CXSRM6-PS	Includes the kit components of the seal kit featured on page 177 plus items ⑨ and ⑩ from the left parts list.
	CXSRL6APS	
10	CXSRM10-PS	
	CXSRL10APS	
15	CXSRM15-PS	
	CXSRL15APS	
20	CXSRM20-PS	
	CXSRL20APS	
25	CXSRM25-PS	
	CXSRL25APS	
32	CXSRM32-PS	
	CXSRL32APS	

* Seal kits includes the basic type seal (page 177), ⑨ and ⑩. Order the seal kit based on each bore size.

* Since the seal kit does not include a grease pack, it should be ordered separately.

Grease pack part no.:GR-S-010 (10 g)