



Installation and Maintenance Manual

Series VG342 Solenoid Valve 3 Port Pilot Poppet Type

For future reference, please keep this manual in a safe place

This manual should be read in conjunction with the current valve catalogue.

Safety Instructions

These safety instructions are intended to prevent a hazardous situation and/or equipment damage. These instructions indicate the level of potential hazard by label of "Caution", "Warning" or "Danger". To ensure safety, be sure to observe ISO4414 (Note 1), JIS B 8370 (Note 2) and other safety practices.

Note 1: ISO 4414: Pneumatic fluid power – Recommendations for the application of equipment to transmission and control systems.
Note 2: JIS B 8370: Pneumatic system axiom.

CAUTION : Operator error could result in injury or equipment damage.

WARNING: Operator error could result in serious injury or loss of life.

DANGER : In extreme conditions, there is a possible result of serious injury or loss of life.

WARNING

1. The compatibility of pneumatic equipment is the responsibility of the person who designs the pneumatic system or decides its specifications.

Since the products specified here are used in various operating conditions, their compatibility for the specific pneumatic system must be based on specifications or after analysis and/or tests to meet your specific requirements.

2. Only trained personnel should operate pneumatically operated machinery and equipment.

Compressed air can be dangerous if an operator is unfamiliar with it. Assembly, handling or repair of pneumatic systems should be performed by trained and experienced operators.

3. Do not service machinery/equipment or attempt to remove component until safety is confirmed.

- 1) Inspection and maintenance of machinery/equipment should only be performed after confirmation of safe locked-out control positions.
- 2) When equipment is to be removed, confirm the safety process as mentioned above. Switch off air and electrical supplies and exhaust all residual compressed air in the system.
- 3) Before machinery/equipment is re-started, ensure all safety measures to prevent sudden movement of cylinders etc. (Bleed air into the system gradually to create back-pressure, i.e. incorporate a soft-start valve).

4. Contact SMC if the product is to be used in any of the following conditions:

- 1) Conditions and environments beyond the given specifications, or if product is used outdoors.
- 2) Installations in conjunction with atomic energy, railway, air navigation, vehicles, medical equipment, food and beverage, recreation equipment, emergency stop circuits, press applications, or safety equipment.
- 3) An application which has the possibility of having negative effects on people, property, or animals, requiring special safety analysis.

CAUTION

Ensure that the air supply system is filtered to 5 micron.

Valve Specifications

Type of actuation	Common to NC/NO	
Operation	Internal pilot type	External pilot type
Operating pressure range	0.2~0.9MPa (2.0~9.2 kgf/cm ²)	-101.2 kPa~0.9MPa (1 Torr)~9.2 kgf/cm ²)
External pilot pressure	-	Refer to the table below
Note 1: Response time	30ms max. (at 0.5MPa [5.1 kgf/cm ²])	
Max. operating frequency	5c/s (Min. operating frequency: 1c/30 days as per JIS B8374-1981)	
Ambient and fluid temperature	Max. 50°C (Note 2)	
Lubrication	Not required (use turbine oil #1 ISO VG32 if lubrication is provided)	
Manual override	Non-locking push type	
Note 3: Mounting position	Free	
Impact/vibration resistance	150, 50m/S ² (45~1000Hz)	
Weight	*1.1kg	

Note 1: As per JIS B8374-1981 dynamic performance test (at rated voltage without surge voltage protection circuit at coil temp. 20°C).

Note 2: Possible to use down to -10°C. However please take care that moisture does not freeze.

Note 3: Shock resistance: No malfunction from test using drop impact tester, to axis and right angle direction of main valve and armature, each one time when energised and de-energised.

Vibration resistance: No malfunction from test with 8.3~2000Hz 1 sweep, to axis and right angle direction of main valve and armature, each one time when energised and de-energised. (Value in the initial stage.)

External pilot specifications

Main pressure	101.2kPa~0.2MPa (1 Torr)~2.0 kgf/cm ²)	0.2~0.5MPa (2.0~5.1 kgf/cm ²)
External pilot pressure	0.2~0.9MPa (2.0~9.2 kgf/cm ²)	Equivalent to main pressure

Installation

CAUTION

Ensure all Air and Power supplies are isolated before commencing installation.

WARNING

DO NOT INSTALL THESE VALVES IN EXPLOSIVE ATMOSPHERES.

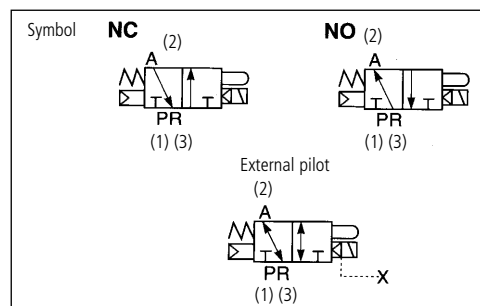

Fig 1

If these valves are exposed to water or oil droplets, ensure that the valves are protected.

If it is intended to energise a valve for an extended period please consult SMC.

Lubrication

These valves have been lubricated for life at manufacture and require no additional lubrication.

CAUTION

However, if a lubricant is to be used, a turbine oil type #1 (ISO VG32) should be used. If a lubricant is used, continuous lubrication must be carried out as the original lubricant will be washed away.

Pilot valve assembly specifications

Electrical entry	AC(50/60Hz)	100, 200, 24, 48, 110, 220, 240
Coil rated voltage	DC	24, 6, 12, 48
Allowable voltage		-15%~+10% at rated voltage
Note 1: Apparent power	AC	Inrush: 12.7VA (50Hz) 10.7VA (60Hz) Holding: 7.6VA(50Hz) 5.4VA (60Hz)
Power consumption	DC	w/o lamp...4.8W w/lamp...5W
Note 2: Lamp and surge voltage suppresser	AC	ZNR (Neon lamp)
	DC	Diode LED
Protective structure		IP65

Note 1: At rated voltage

Note 2: Semi-standard

Low consumption type VO307Y specifications

Use type DC2W VO307Y when an electronic control, etc. requires low power consumption.

The following specification is different from the standard one.

Power consumption	*DC2W, 2.2W with lamp
-------------------	-----------------------

* 100VDC: 2.4W, 2.6W with lamp

Electrical connection (Fig 2)

In the case of a DIN terminal (with a lamp/surge voltage protection circuit) the connections are as follows. Connect each to the power supply side.

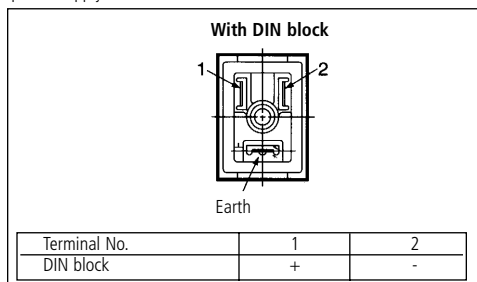

Fig 2

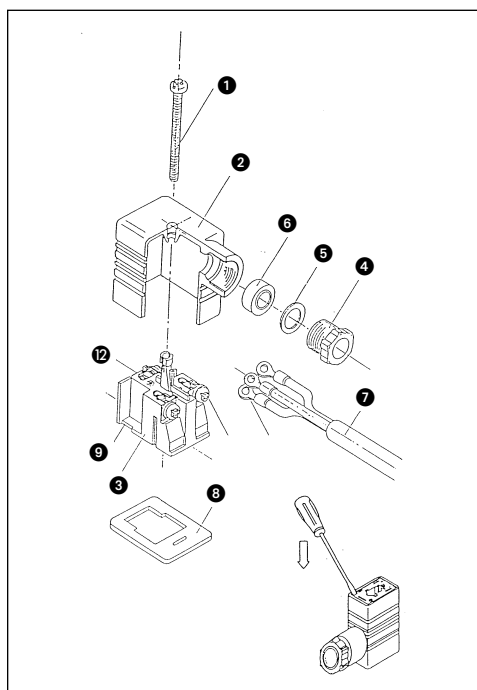

Fig 3

Disassembly (Fig 3)

1. Loosen screw 1 and pull housing 2 directly upward to remove connector from the device (such as solenoid).
2. Pull out screw 1 from housing 2.
3. Notch 9 indicated by an arrow is at the bottom of terminal block 3. Insert straight-edge screwdriver in the clearance between housing 2 and terminal block 3, and pry housing 2 off to remove terminal block 3. Refer to Fig 3.
4. Remove cable ground 4, and take out washer 5 and rubber packing 6.

Wiring (Fig 3)

1. Pass cable ground 4, washer 5 and rubber packing 6 through cable 7 and insert these in housing 2.
2. Peel off a proper length of the coating of cable 7 as shown in the figure below and connect the cable end with crimp-style terminal 10.

3. Remove screw 11 (or loosen Y-shaped terminal) from terminal block 3, mount crimp-style terminal 10 to terminal block 3 and tighten screw 11 securely.

Note: Tighten screw with torque range of 5 kgf/cm±15%.

Remarks:

- a) Wiring can be done with bare cables. In such a case, loosen screw with washer 11, put lead wires in bracket 12 and tighten the screw again.
- b) Maximum outer diameter of cable terminal 7 should range from ø4.5mm to ø7.0mm.
- c) Applicable crimp-style terminals 10 are shown in the table.

O-shaped terminal	Y-shaped terminal	O-shaped terminal	Y-shaped terminal	O-shaped terminal	Y-shaped terminal
0.3-3	0.3-3	1.25-3	1.25-YAS3	0.5-3	1.25-B3A
1.25-3	1.25Y-3		1.25-YAS3.5	1.25-3	1.25-C3A
1.25-3S	1.25Y-3.5				

Assembly

1. Pass parts through cable 7 in order of cable ground 4, washer 5, rubber packing 6 and housing 2. Connect cable 7 to terminal block 3. Then press terminal block 3 into housing 2 until it clicks in place.
2. Put parts into the cable inlet of housing 2 in order of rubber packing 6 and washer 5, and tighten cable ground 4 securely.
3. Place gasket 8 in between the bottom part of terminal block 3 and plug on device. Insert and tighten screw 11 over the housing 2.

Note: Tighten screw with torque range of 5 kgf/cm±20%.

Remark: Connector orientation can be changed an angle of 180 degrees depending on the assembling of housing 2 and terminal block 3.

Method of changing valve condition

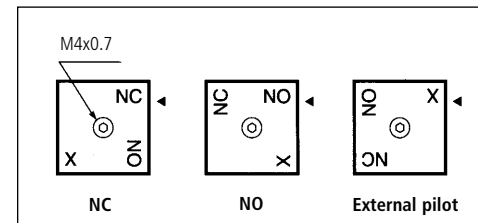

Fig 4

When changing the valve condition confirm that all pressure has been removed from the valve. Unscrew the M4x0.7 hexagon socket head cap screw located in the changeover plate, and match the mark on the adapter plate with the character on the changeover plate. Piping is as shown below:-

Piping

Port	P	A	R
Passage			
NC	Primary side	Secondary side	Exhaust side (plug, in case of two-way valve)
NO	Exhaust side (plug, in case of two-way valve)	Secondary side	Primary side
External	Universal supporting (Piping of primary side is possible to anywhere)		

Note 1: In case of internal pilot, confirm that a plug is inserted to X port. If not, insert a R(PT) 1/8 plug.

Note 2: In case of external pilot, supply air pressure from X port.

Note 3: Take care that no dust or foreign substance enters valve from

unused port like EXH port.

Note 4: This solenoid valve is pilot type so do not meter primary pressure because of pressure drop. It might cause malfunction.

Lamp/surge voltage protection circuit

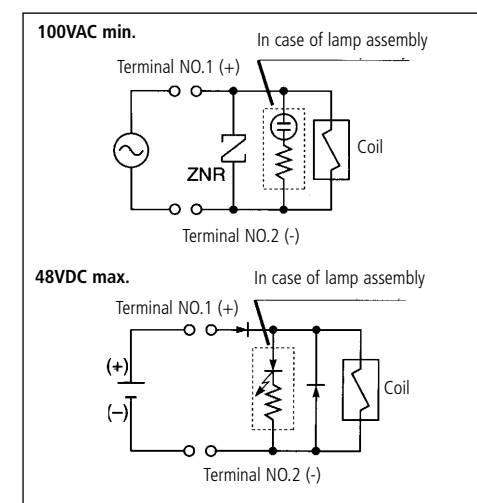

Fig 5

Used circumstance

Please take care of not accumulating dust or foreign substance on manual override part because of a breathing hole there.

Caution about protection constructure

Protection constructure is to aim the safeguard from contact by worker, intrusion of foreign substance or water. This valve has IP65 protection structure, but please use like protection cover, if this is installed outdoor.

WARNING

Manual override operation

Exercise extreme CAUTION when operating a solenoid manual override as connected equipment will commence operation. Ensure all safety measures are in place.

WARNING

Maintenance

UNDER NO CIRCUMSTANCES ATTEMPT TO CHANGE THE SOLENOID AS THIS IS AN INTEGRAL PART OF THE VALVE AND DOING SO WILL NEGATE ANY SUCH SMC WARRANTY.

CAUTION

Leakage voltage (Fig 6)

Please note, if a C-R element is used for contact protection, please allow for an increase of leakage voltage which may pass through the C-R element.

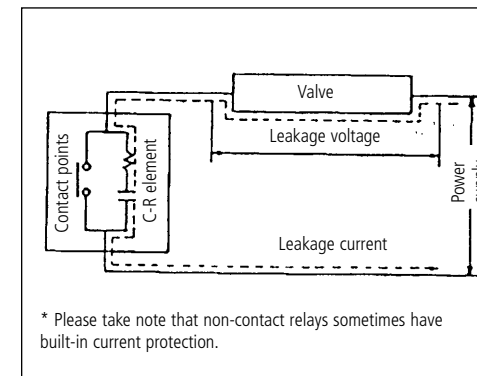

Fig 6

The percentage of leakage voltage that remains on both ends of the coil after de-energisation should be kept under 15% in the case of an AC coil, and under 3% in the case of a DC coil, of the rated voltage.

CAUTION

1. Since PE port is the exhaust port of the pilot valve, do not plug this port or in any way reduce the diameter.
2. The X port is the pressure supply port of the pilot valve and the PE port is the exhaust port of the pilot valve. Avoid mismatching these ports when piping.

When you enquire about the product, please contact the following

SMC Corporation:			
ENGLAND	Phone 01908-563888	GERMANY	Phone 6103-402-0
ITALY	Phone 02-92711	FRANCE	Phone 1-64-76-10-00
HOLLAND	Phone 020-5318880	SWEDEN	Phone 08-603-07-00
SWITZERLAND	Phone 052-34-0022	AUSTRIA	Phone 02262-62-280
SPAIN	Phone 945-290600	IRELAND	Phone 01-4501822
GREECE	Phone 01-3426076	DENMARK	Phone 8738-0800
FINLAND	Phone 9-68-10-21	NORWAY	Phone 67-12-90-20
BELGIUM	Phone 03-3551464	POLAND	Phone 48-22-6131847
TURKEY	Phone 212-2211512		