



Installation and Maintenance Manual
Series SGC 200/300/400

For future reference, please keep this manual in a safe place

This manual should be read in conjunction with the current catalogue.

These safety instructions are intended to prevent a hazardous situation and/or equipment damage. These instructions indicate the level of potential hazard by label of "Caution", "Warning" or "Danger". To ensure safety, be sure to observe ISO4414 (Notes) and other safety practices.
 Note 1 : ISO 4414:Pneumatic fluid power -Recommendations for the application of equipment to transmission and control systems.

- CAUTION:** Operator error could result in injury or equipment damage.
- WARNING:** Operator error could result in serious injury or loss of life.
- DANGER:** In extreme conditions, there is a possible result of serious injury or loss of life.

- WARNING**
- The compatibility of pneumatic equipment is the responsibility of the person who designs the pneumatic system or decides its specifications.**
 - Since the products specified here are used in various operating conditions, their compatibility for the specific pneumatic system must be based on; the specifications, post analysis and/or tests to meet the specific requirements. The expected performance and safety assurance are the responsibility of the person who has determined the compatibility of the system. This person should continuously review the suitability of all items specified, referring to the latest catalog information with a view to giving due consideration to any possibility of equipment failure when configuring a system.
 - Only trained personnel should operate pneumatically operated machinery and equipment.**
 - The fluid can be dangerous if handled incorrectly. Only trained and experienced operators should assemble or repair the pneumatic systems.
 - Do not service machinery/equipment or attempt to remove component until safety is confirmed.**
 - Inspection and maintenance of machinery/ equipment should only be performed once measures to prevent falling or runaway of the driver objects have been confirmed.
 - When equipment is to be removed, confirm the safety process as mentioned above. Shut off the supply pressure for this equipment and exhaust all residual compressed air in the system.
 - Carefully restart the machinery, confirming that safety measures are being implemented.
 - Contact SMC if the product is to be used in any of the following conditions:**
 - Conditions and environments beyond the given specifications, or if product is used outdoors.
 - With fluids whose application causes concern due to the type of fluid or additives, etc.
 - An application which has the possibility of having negative effects on people, property, or animals, requiring special safety analysis.

- CAUTION**
- Ensure that the air supply system is filtered to 5 micron.

Valve Specifications

Specifications		SGC200/300/400
Type		SGC200/300/400
Operating fluid		Coolant
Fluid temperature	SGC□□□A,B	-5 to 60°C (No freezing)
Ambient temperature	°C	-5 to 50°C (No freezing)
Proof pressure		2.4 MPa
Leakage from the valve seat		20 cm ³ /min of less (water pressure)
Operating Pressure range	SGC□□□□-05	0 to 0.5 MPa
	SGC□□□□-10	0 to 1 MPa
	SGC□□□□-16	0 to 1.6 MPa
External air operated	SGC□□01	0.25 to 0.7 MPa
	SGC□□02	0.5MPa specification : 0.25 MPa to 0.7 MPa 1.0, 1.6 MPa specification : 0.3 MPa to 0.7 MPa
Lubrication		Not required (Use turbine oil Class 1 (ISO VG32), if lubricated.
Temperature		-5 to 50 °C (No freezing)

Note :Impact resistance: No malfunction occurred when it was tested with a droptester in the axial direction and at right angles to the main valve & armature; in both energized & de-energized states and for every time in each condition (Values at the initial period.)
 Vibration resistance: No malfunction occurred in a one-sweep test between 45 and 2000 Hz. Test was performed at both energized and de-energized stated in the axial direction and at right angles to the main valve & armature. (Values at the initial period.)

Pilot Solenoid Valve Specifications

Pilot solenoid valve specification		V116-□□□-1	
Electrical entry		Conduit terminal, DIN terminal, M12 connector	
Coil rated voltage V	DC	12V, 24V	
	AC (50/60 Hz)	100V, 110V, 200V, 220V	
Allowable voltage fluctuation		±10% of rated voltage (Note)	
Power consumption W	DC	0.35 W (With indicator light : 0.58 W)	
	100V	0.78 (With indicator light : 0.87)	
Apparent voltage VA	AC	110V [115V]	0.86 (With indicator light : 0.97)
		200V	0.94 (With indicator light : 1.07)
		220V [230V]	1.15 (With indicator light : 1.30)
		220V [230V]	1.27 (With indicator light : 1.46)
Surge voltage suppressor		ZNR (Varistor)	
Indicator light		LED (Neon bulb when AC with DIN terminal and M12 connector)	

Note) In common between 110 VAC and 115 VAC, and between 220 VAC and 230 VAC.
 For 115 VAC and 230 VAC, the allowable voltage is -15% to +5% of rated voltage.

JIS Symbol

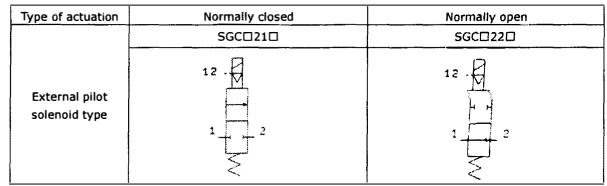

Light/Surge Voltage Suppressor

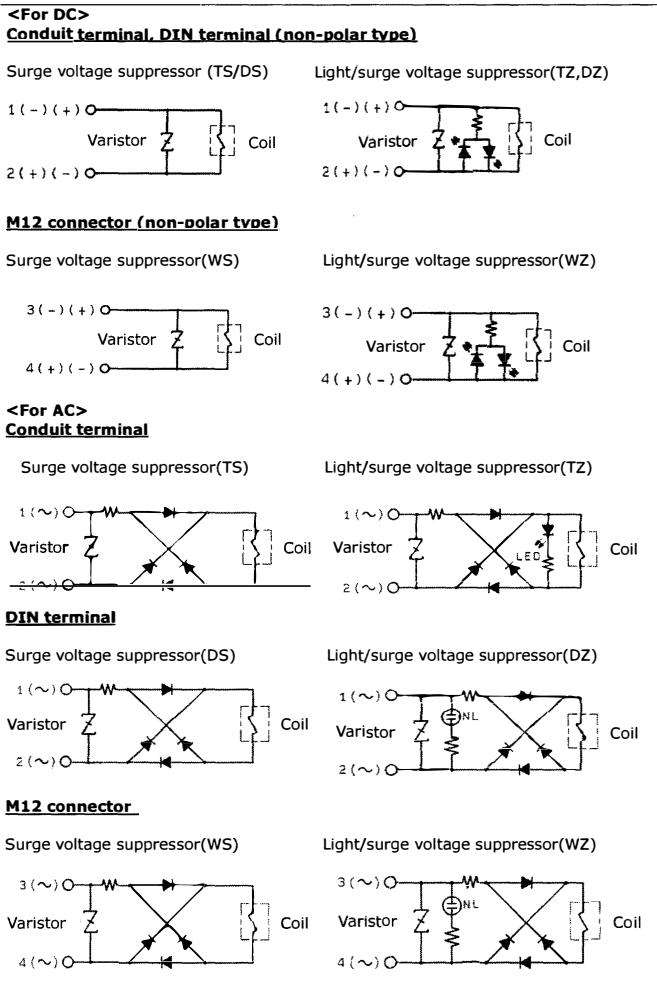

M12 connector

CAUTION

- M12 connector types have an IP65 (enclosure) rating, offering protection from dust and water. However please note: these products are not intended for use in water.
- Do not use a tool to mount the connector, as this may cause damage. Only tighten by hand. (0.4 to 0.6 N·m)
- The excessive stress on the cable connector will not be able to satisfy the IP65 rating. Please use caution and do not apply a stress of 30N or greater.

Failure to meet IP65 performance may result if using alternative connectors than those shown above, or when insufficiently tightened.

Note) To connect a cable with a female connector:

Adjust the connector key to the M12 connector key in the side of the valve so that they are in the same orientation. Be careful not to squeeze it in the wrong direction, as problems such as pin damage may occur.

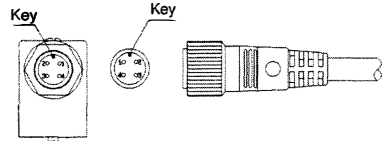

CAUTION

Connector with cable.

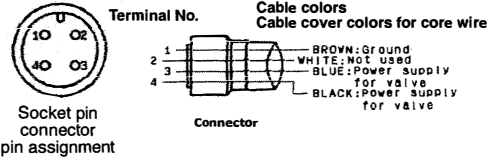
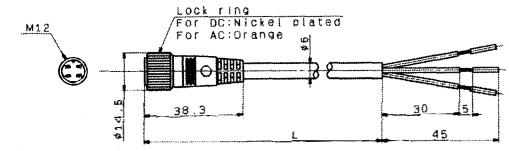
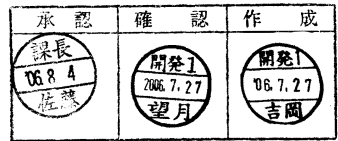
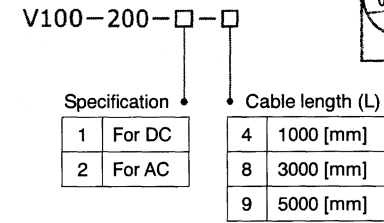

How to Order

Include the part number of the female connector with cable together with the part number for the solenoid valve.
 Example) In case of lead wire length, 1000mm

For DC	For AC
SGC221A-0510-SWZ	SGC221A-0510-1WZ
V100-200-1-4	V100-200-2-4

How to Use Conduit terminal

CAUTION

Conduit terminal types have an IP65 (enclosure) rating, offering protection from dust and water. However please note: these products are not intended for use in water.

Connection

- Loosen the holding screws and remove the cover from the terminal block.
 - Loosen the screws in the terminal block. Insert the lead core wires or crimped terminals to the terminals, and secure the wires by retightening the terminal screw.
 - Secure the core wires by fastening the ground nut.
- When making connections, take note that using heavy duty cored wires other than the supported sizes (φ4.5 to φ7) will not satisfy IP65 (enclosure) standards. Also, be sure to tighten the ground nut and holding screw to within their specified torque ranges.

Compatible cable

Cord O.D. : $\varnothing 4.5$ to $\varnothing 7$
 (Reference) 0.5 to 1.5mm² 2-core or 3-core, equivalent to JIS C3306

Applicable crimped terminals

O-terminals : Equivalent to R1.25 -3 defined in the JIS C2805
 Y- terminals : Equivalent to 1.25 -3 manufactured by J.S.T Mfg. Co., Ltd.

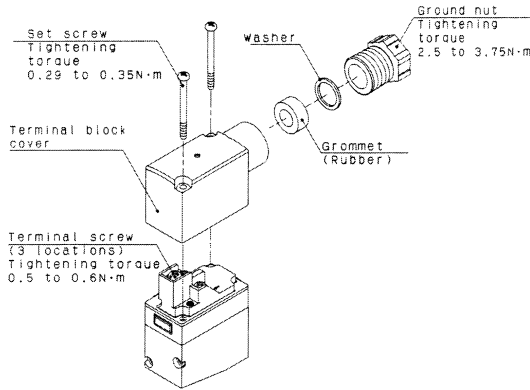

How to Use DIN Terminal

CAUTION

DIN terminal types have an IP65 (enclosure) rating, offering protection from dust and water. However please note: these products are not intended for use in water.

Connection

- 1) Loosen the holding screw and pull the connector out of the solenoid valve terminal block.
- 2) After removing the holding screw, insert a flat head screwdriver, etc. into the notch on the bottom of the terminal block and pry it open, separating the terminal block and the housing.
- 3) Loosen the screw (slotted screws) in the terminal block. Insert the lead core wires or crimped terminal to the terminals according to the connection method, and secure the wires by re-tightening the terminal screw.
- 4) Secure the cord by fastening the ground nut.

When making connections, take note that using heavy duty cored wires other than the supported sizes ($\varnothing 4.5$ to $\varnothing 7$) will not satisfy IP65 (enclosure) standards. Also, be sure to tighten the ground nut and holding screw to within their specified torque ranges.

Changing the entry direction

After separating the terminal block and housing, the cord entry can be changed by attaching the housing in the opposite direction 180°.
 *Be careful not to damage the element, etc. with the cord's lead wires.

Caution

Plug in and pull out the connector vertically without tilting to one side.

Compatible cable

Cord O.D. : $\varnothing 4.5$ to $\varnothing 7$
 (Reference) 0.5 to 1.5mm² 2-core or 3-core, equivalent to JIS C3306

Applicable crimped terminals

O-terminals : Equivalent to R1.25 -4M defined in the JIS C2805
 Y- terminals : Equivalent to 1.25 -3L manufactured by J.S.T Mfg. Co., Ltd.
 Bar-terminals : up to size 1.5

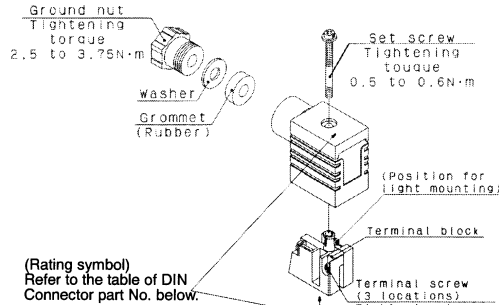

Circuit Diagram with Light/Surge Voltage Suppressor

AC circuit diagram

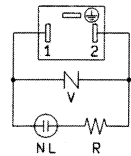

NL : Neon Lamp, R : Resistor
 V : Varistor

DC circuit diagram

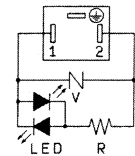

LED : Light Emitting diode, R : Resistor
 V : Varistor

Precautions on Design

WARNING

1. **Cannot be used as an emergency shut-off valve.**
 The valves presented in this catalog are not designed for safety applications such as an emergency shutoff valve. If the valves are used in this type of system, other positive measures for safety should be also adopted in conjunction.
2. **Solenoid valves are not allowed to be used in potentially explosive atmospheres**
3. **Maintenance space.**
 The installation should provide with sufficient space for maintenance activities. (removal of valve, etc.)
4. **Liquid rings**
 In cases with a flowing liquid, provide a by-pass valve in the system to prevent the liquid from entering the liquid seal circuit.

Selection

WARNING

1. **Confirm the specifications.**
 Do not operate at pressures or temperatures beyond the range of specifications, as this can damage the valve or cause it to malfunction. (Refer to specifications in catalog.)

CAUTION

1. **Voltage leakage.**
 When C-R device (surge suppressor) is used for the protection of switching device, note that voltage leakage will be increased by passing voltage leakage through C-R device. Therefore, select circuit or device which can limit residual voltage leakage to following value. And for recovery failure due to voltage leakage, bleeder resistance should be placed. For further information of bleeder resistance, contact SMC.
With AC coil : 8% or less of rated voltage.
With DC coil : 3% or less of rated voltage.
2. **Low temperature operation.**
 - 1) The valve can be used at extreme temperatures of -5°C. Take appropriate measures to avoid freezing of drainage, moisture etc in pilot air line, by using an air dryer.
 - 2) When using valves for water applications in cold climates, take appropriate countermeasures to prevent the freezing. i.e. drain the water that is left in the tubing after the water supply has

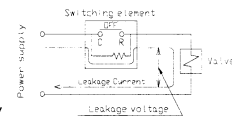

been shut off.
 When heating by steam, be careful not to expose the pilot valve portion to steam. Installation of a dryer in the pilot air line and heat retaining of the body are recommended to prevent freezing in conditions that the dew-point temperature is high and ambient temperature is low.

3. Operating fluids.

- 1) Type of operating fluids.
 Select model according to the material compatibility of the operating fluid. Please contact SMC for further information.

4. Quality of operating fluids

Using fluid that contains foreign matter can cause problems and malfunctions such as; seal failure due to wear on the valve seat, and sticking sliding parts etc. install a suitable filter (strainer) immediately up stream of the valve.

5. Quality of operating air.

- 1) **Use clean air.**
 If the compressed air supply includes chemicals, synthetic materials (including organic solvents), salinity, corrosive gas, etc., it can damage or lead to a malfunction.
- 2) **Install an air filter.**
 Install an air filter at the up stream side to the valve. Filtration degree should be 5 μ m or less.
- 3) **Install an air dryer, after cooler, etc.**
 Compressed air that includes excessive drainage may cause the valve and other pneumatic equipment to malfunction. To prevent this, install an air dryer or after cooler, etc.

4) If excessive carbon powder is seen, install a mist separator on the upstream side of the valve.

If excessive carbon powder is generated by the compressor, it may adhere to the inside of valves and cause it to malfunction. For compressed air quality, refer to "Air Cleaning Equipment" catalog.

6. Ambient environment

Operate within the ambient operating temperature range. After confirming the compatibility of the product's component materials with the ambient environment, operate so that fluid does not adhere to the product's exterior surfaces.

7. Countermeasures for static electricity.

Static electricity may be generated when using certain fluids, implement suitable countermeasures.

Mounting

WARNING

1. **If the air leakage increases or equipment does not operate properly, stop operation.**
 Check mounting conditions after air and power supplies are connected. Initial function and leakage tests should be performed after installation.
2. **Instruction manual (this documentation)**
 Install valve only after reading and understanding the safety instructions. Keep on file so that it can be referred to when necessary.
3. **Coating**
 Warnings or specifications indicated on the product should not be erased, removed, or covered up.

CAUTION

1. **Do not apply external force to the pilot valve section.**
 Apply spanner to the external connection part when tightening.
2. **Do not warm the pilot valve assembly part by the heat insulation material, etc.**
 Tape heater for anti-freezing is only suitable for use on the piping or the body.
3. **Fittings made from materials other than steel or copper should be tightened with a bracket.**
4. **Do not use in locations subjected to vibrations. If impossible, arm from the body should be as short as possible to prevent resonance.**

Piping

CAUTION

1. **Preparation before piping**
 Before piping is connected, it should be thoroughly blown out with air (flushing) or washed to remove chips, cutting oil and other debris from inside the pipe. Install piping so that it does not apply pulling, pressing, bending or other forces on the valve body.
2. **Sealant tape**
 When installing piping or fitting into a port, ensure that sealant material does not enter the port internally. Furthermore, when sealant tape is used, leave 1.5 to 2 thread ridges exposed at the end of the threads.

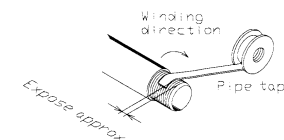

3. Avoid connection of ground lines to piping, as this may cause electric corrosion of the system.

4. Always tighten threads with the proper tightening torques.

When screwing fittings into valves, tighten with the proper tightening torque shown below.

Tightening Torque for Piping

Connection thread	Applicable tightening torque (N.m)
Rc1/8	7 to 9
Rc3/8	22 to 24
Rc1/2	28 to 30
Rc3/4	28 to 30
Rc1	36 to 38

5. Connection of piping to products

When connecting piping to a product, avoid mistakes regarding the supply port, etc.

Wiring

⚠ CAUTION

1. Applied voltage.

When electric power is connected to the solenoid valve, be careful to apply the proper voltage. Improper voltage may cause malfunction or coil damage.

2. Confirm the connections.

After completing the wiring, confirm that the connections are made correctly.

3. Use electrical circuits that do not generate chattering in their contacts.

4. Use a voltage that is within $\pm 10\%$ of the rated voltage.

5. When a surge from the solenoid affects the electrical circuitry, adopt an option that comes with the surge voltage protection circuit.

Operating Environment

⚠ WARNING

① **Do not use in atmospheres where the valve is in direct contact with corrosive gases, chemicals, salt water, steam.**

② **Products with IP65 enclosures (based on IEC60529) are protected against dust and water, however, these products cannot be used in water.**

③ **Products compliant to IP65 Satisfy the specifications by mounting each product properly. Be sure to read the Precautions for each product.**

④ **Do not use in explosive atmospheres.**

⑤ **Do not use in a place subject to heavy vibrations and/or shocks. Check the specifications for each series.**

Refer to the Catalog.

⑥ **The valve should not be exposed to prolonged sunlight. Use a protective cover.**

⑦ **Remove the emissive heat when there is a source of heat around there.**

⑧ **Employ suitable protective measures in locations where there is contact with water droplets, oil or welding spatter, etc.**

Maintenance

⚠ WARNING

① **Perform maintenance procedures as shown in the instruction manual. (This documentation)**

If the valve is handled improperly, then malfunctions or damage of machinery/equipment may occur.

② Removing the product

Confirm that the valve has cooled sufficiently before performing work. If touched inadvertently, there is a danger of being burned.

① Shut off the fluid supply and release the fluid pressure in the system.

② In the case of air pilot or air-operated type, shut off the air supply source and discharge the compressed air inside a pilot piping.

③ Shut off the power supply.

④ Remove the product.

③ Low frequency operation.

In order to prevent malfunction, conduct a switching operation of a valve every 30 days.

(Use caution regarding the air supply.)

Also, in order to use it under the optimum state, conduct a regular inspection once a half year.

④ Manual override

When the manual override is operated, connected equipment will be actuated.

⑤ Do not disassemble the product. Products that have been disassembled

cannot be guaranteed.

⚠ CAUTION

① **Filters and strainers**

1. Be careful regarding clogging of filters and strainers.

2. Replace filter elements after one year of use, or earlier if the pressure drop reaches 0.1 MPa.

3. Clean strainers when the pressure drop reaches 0.1 MPa.

② **Lubrication (Pilot air line)**

When using after lubricating, never forget to lubricate continuously.

③ **Storage**

In case of long term storage after use with heated water, thoroughly remove all moisture to prevent rust and deterioration of rubber materials, etc.

④ **Drain flushing**

Remove drainage from air filters regularly. (Refer to the specifications.)

Precautions on Handling

⚠ WARNING

Valves will reach high temperatures from high temperature fluids. Use caution, as there is a danger of being burned if a valve is touched directly.

When you enquire about the product, please contact the following

SMC CORPORATION:

ENGLAND	01908-563888	TURKEY	212-2211512
ITALY	02-92711	GERMANY	6103-402-0
HOLLAND	020-5318888	FRANCE	01-64761000
ITALY	052-34-0022	SWEDEN	08-6030700
SPAIN	945-184100	AUSTRIA	02262-62-280
SWITZERLAND	902-255255	IRELAND	01-4501822
GREECE	01-3426076	DENMARK	87 38 87 00
FINLAND	09-68 10 21	NORWAY	67 12 90 20
BELGIUM	03-3551464	POLAND	48-22-6131847