



Installation and Maintenance Manual

Fan Type Ionizer

IZF21/31 Series



1 Safety Instructions

This manual contains essential information for the protection of users and others from possible injury and/or equipment damage.

- Read this manual before using the product, to ensure correct handling, and read the manuals of related apparatus before use.
- Keep this manual in a safe place for future reference.
- These instructions indicate the level of potential hazard by label of "Caution", "Warning" or "Danger", followed by important safety information which must be carefully followed.
- To ensure safety of personnel and equipment the safety instructions in this manual and the product catalogue must be observed, along with other relevant safety practices.

Caution	Indicates a hazard with a low level of risk, which if not avoided, could result in minor or moderate injury.
Warning	Indicates a hazard with a medium level of risk, which if not avoided, could result in death or serious injury.
Danger	Indicates a hazard with a high level of risk, which if not avoided, will result in death or serious injury.

Warning

- The compatibility of pneumatic equipment is the responsibility of the person who designs the pneumatic system or decides its specifications. Since the products specified here can be used in various operating conditions, their compatibility with the specific pneumatic system must be based on specifications or after analysis and/or tests to meet specific requirements.
- **Only trained personnel should operate pneumatically operated machinery and equipment.**
Compressed air can be dangerous if an operator is unfamiliar with it. Assembly, handling or repair of pneumatic systems should be performed by trained and experienced personnel.
- **Do not service machinery/equipment or attempt to remove components until safety is confirmed.**
 - 1) Inspection and maintenance of machinery/equipment should only be performed after confirmation of safe locked-out control positions.
 - 2) When equipment is to be removed, confirm the safety process as mentioned above. Switch off air and electrical supplies and exhaust all residual compressed air in the system.
 - 3) Before machinery/equipment is re-started, ensure all safety measures to prevent sudden movement of cylinders etc. (Supply air into the system gradually to create back pressure, i.e. incorporate a soft-start valve).
- **Do not use this product outside of the specifications. Contact SMC if it is to be used in any of the following conditions:**
 - 1) Conditions and environments beyond the given specifications, or if the product is to be used outdoors.
 - 2) Installations in conjunction with atomic energy, railway, air navigation, vehicles, medical equipment, food and beverage, recreation equipment, emergency stop circuits, press applications, or safety equipment.
 - 3) An application which has the possibility of having negative effects on people, property, or animals, requiring special safety analysis.

Caution

- Ensure that the air supply system is filtered to 5 microns.

2 Specifications

Refer to the operation manual for this product.

3 Installation

3.1 Installation

Warning

- Do not install the product unless the safety instructions have been read and understood.
- **Provide space for maintenance, inspection and wiring.**
Install the product in consideration of the connector and the emitter cartridge mounting so that there is enough space for emitter maintenance, inspection and wiring.
To avoid unreasonable stress applied to the connector, bending of the cable should not be less than the minimum bending radius. If the cable is bent in an acute angle or load is applied to the cable repeatedly, it may cause malfunction or wire damage.
- **Mount the product on a flat surface.**
Mounting on an uneven surface will apply excess force to the frame or case, which leads to damage or failure. Do not drop the product or subject it to a strong impact. This may cause an injury or accident.
- **Avoid using in a place where noise (electromagnetic wave and surge) is generated.**
If the product is used in an environment where noise is generated, it may lead to deterioration or damage of the internal elements. Take measures to prevent noise at its source and avoid power and signal lines from coming into close contact.
- **Use the correct tightening torque.**
If the screws are tightened in excess of the specified torque range, it may damage the mounting screws, mounting brackets, etc. If the tightening torque is insufficient, the mounting screws and brackets may become loose.
- **Do not adhere tape or labels onto the product body.**
If the tape or label contains conductive adhesive or reflective paint, it is possible that due to the dielectric effect, charge could build up causing an electro-static discharge or electrical leakage.
- **Be sure to cut off the power supply before installing or adjusting the product.**

Caution

- **Provide sufficient space at the rear side of the ionizer to allow the fan to absorb air.**
This product ventilates using a fan motor. If there are obstacles such as a wall on the rear side (air absorption side) of the ionizer, ventilation will be obstructed, decreasing the static neutralization performance. Install the ionizer so that its rear surface is at least 20 mm (for IZF21) or 30 mm (for IZF31) away from any obstacles.
- **Make sure to confirm the effect of static neutralization after installation.**
The effect of the static neutralization varies depending on the surrounding installation and operating conditions. Confirm the effect of the static neutralization after installation.
- **When installing ionizers which operate in DC mode (one polarity, positive or negative) close together, they should be positioned at least 2 m apart.**
When two ionizers operating in DC mode are to be used close to each other, separate them by at least 2 m. The offset voltage (ion balance) may not be controlled by the built-in sensor due to the ions discharged from the other ionizer in DC mode.
- **Do not apply excessive external force to the finger guard on the air absorption side.**
If an excessive external force is applied to the finger guard (including the filter holder) on the air absorption side, it may be damaged. Do not apply an external force of more than 50 N to the finger guard.

3 Installation (continued)

3.1.1 Precautions for Installation

Be sure to cut off the power supply before installing the product. The emitter cartridge can be mounted / removed with one touch. However, it is also possible to secure it with a screw as required. To secure the emitter cartridge with a screw, use an M3 x 0.5 12 mm cross recessed round head screw (the screw needs to be prepared by the user). The recommended tightening torque is 0.25 to 0.35 Nm. Install the ionizer so that the emitter cartridge can be removed for maintenance and replacement of the emitters.
To remove the emitters for cleaning or replacement, pull it to the air blow side while the part A of the emitter cartridge is being pressed. (If the emitter cartridge is secured with a retaining screw, remove the screw before removing the emitter cartridge).

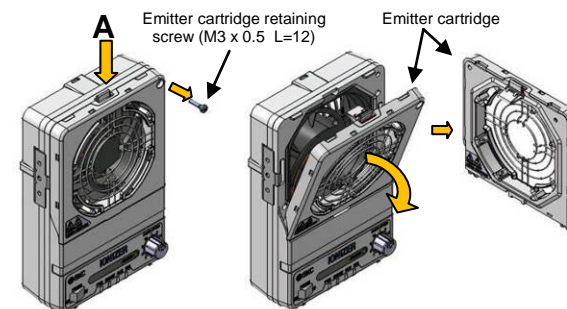

3.1.2 Installation of Ionizer

1) Installation with bracket

When installing the Ionizer with a bracket, secure it with M5 screws using the mounting holes on the bottom of the bracket (The screws need to be prepared by the user). Refer to "6. Dimensions" for details. The angle adjustment range of the bracket is 45 degrees in direction A, and 90 degrees in direction B.

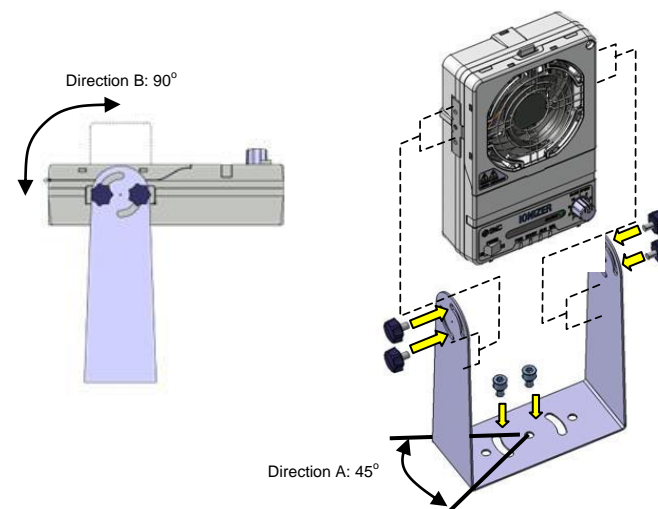

2) Installation without bracket

If a bracket is not used, install the product using the M4 screw holes on both sides of the body. Be sure to secure both sides of the body when fixing the ionizer. (if the product is fixed on one side only, the product body may be damaged. The screws need to be prepared by the user). Refer to "6. Dimensions" for details. The recommended tightening torque is 1.3 to 1.5 Nm.

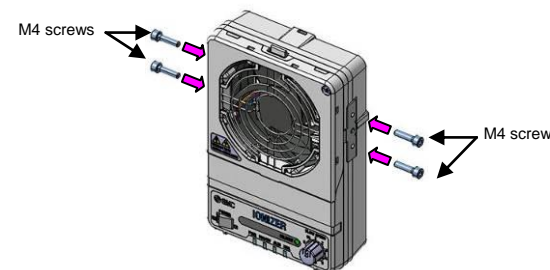

3 Installation (continued)

3.2 Environment

Warning

- Do not use in an environment where corrosive gases, chemicals, salt water or steam are present.
- Do not use in an explosive atmosphere.
- Do not expose to direct sunlight. Use a suitable protective cover.
- Do not install in a location subject to vibration or impact. Check the product specifications.
- Do not mount in a location exposed to radiant heat.
- **Keep within the specified ambient temperature range.**
The specified ambient temperature range for the Ionizer is 0 to 50 °C, and for the AC adapter is 0 to 40 °C. Avoid sudden temperature changes even within the specified ambient temperature range, as it may cause condensation.
- **Do not use this product in an enclosed space.**
This product utilizes the corona discharge phenomenon. Although the amount is very small, Ozone and NOx are generated. Do not use in an enclosed space.
- **Environments to avoid**
Never use or store under the following conditions. These may cause an electric shock, fire, etc.
 - a. Areas where the ambient temperature exceeds the operating temperature range.
 - b. Areas where the ambient humidity exceeds the operating humidity range.
 - c. Areas where abrupt temperature changes may cause condensation.
 - d. Areas where corrosive gas, flammable gas or other volatile flammable substances are stored.
 - e. Areas where the product may be exposed to conductive powder such as iron powder or dust, oil mist, salt, organic solvent, machining chips, particles or cutting oil (including water and any liquids), etc.
 - f. Paths of direct air flow, such as air conditioners.
 - g. Enclosed or poorly ventilated areas.
 - h. Locations which are exposed to direct sunlight or heat radiation.
 - i. Areas where strong electromagnetic noise is generated, such as strong electrical and magnetic fields or supply voltage spikes.
 - j. Areas where the product is exposed to static electricity discharge.
 - k. Locations where strong high frequency is generated.
 - l. Locations that are subject to potential lightning strikes.
 - m. In an area where the product may receive direct impact or vibration.
 - n. Areas where the product may be subjected to forces or weight that could cause physical deformation.

3.3 Wiring

Warning

- **Before wiring, ensure that the power supply capacity meets the specification and that the voltage is within the specification.**
- **To maintain product performance, the power supply shall be UL listed Class 2 certified by National Electric Code (NEC) or evaluated as a limited power source provided by UL60950.**
- **To maintain the product performance, ground the product with an earth ground cable with a resistance of 100 Ω or less according to this manual.**
- **Remove the power supply before wiring (including the connector plug in/out).**
- **Ensure the safety of wiring and surrounding conditions before supplying power.**
- **Do not connect or disconnect the connectors (including power source) while the power is supplied. The ionizer may malfunction.**
- **Malfunctions stemming from noise may occur if the wire is installed in the same route as that of power or high-voltage cable. Route the ionizer wires independently.**
- **Confirm that the wiring is correct before operation. Incorrect wiring will lead to malfunction or may damage the controller or its peripheral devices depending on the seriousness of the wiring error.**

3.3.1 Connection Circuit

Wire cables according to the connection circuit and wiring diagram. Be sure to connect the ground terminal (F.G.) with a ground resistance of 100 Ω or less.
The ground terminal (F.G.) is used as an electrical reference potential for static neutralization. If the ground terminal is not grounded, the ionizer will not be able to achieve the optimal offset voltage (ion balance). In addition, make sure to wire 2 brown cables and 2 blue cables for supplying power to the ionizer.

3 Installation (continued)

Connection circuit NPN Input / output

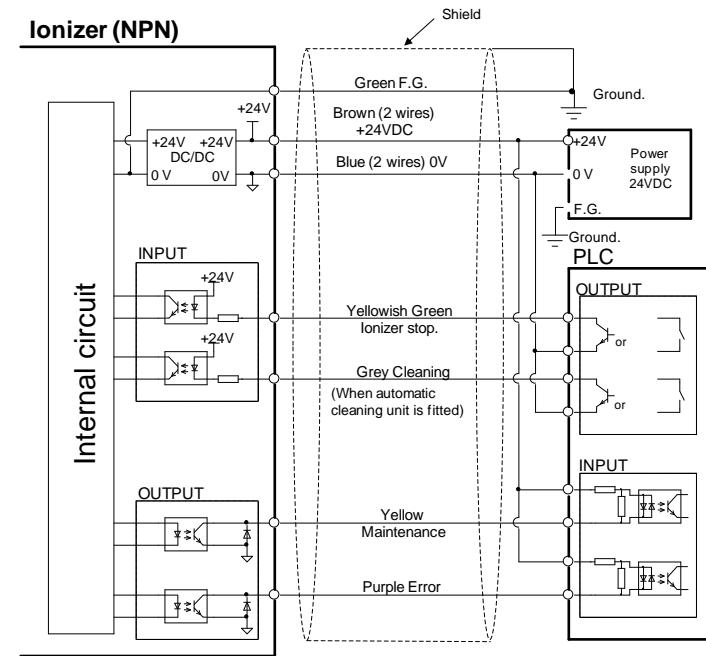

PNP Input / output

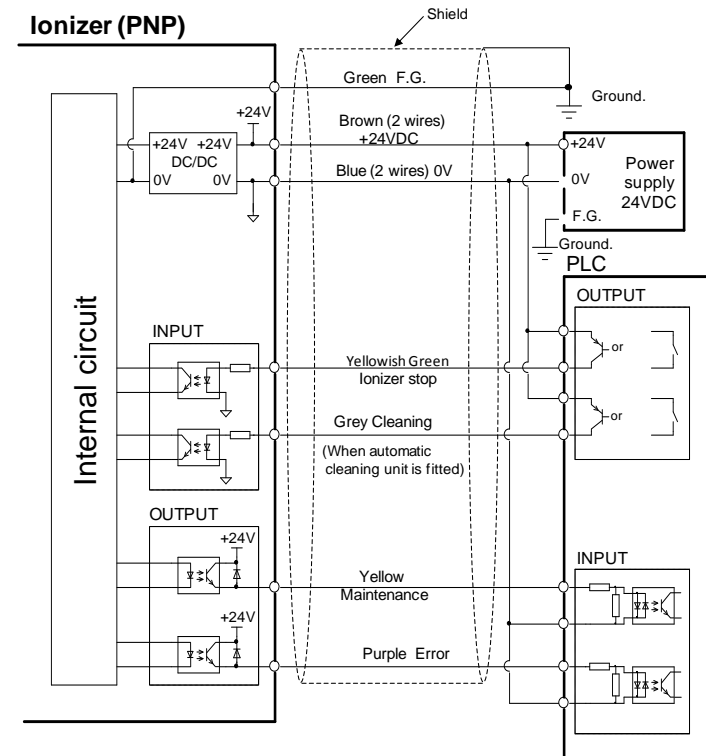

3.3.2 Wiring of the Power Supply Cable

Install the cables with a radius greater than the minimum bending radius to prevent excessive stress from being applied to the cable and/or connectors.

Minimum bend radius: 38 mm

Note: This is the allowable bend radius at 20 °C.

Unused wires should be cut short or insulated to avoid contacting with other wires.

Be sure to connect the 2 brown cables in which a voltage of 24 VDC is supplied and 2 blue cables in which 0 V is supplied to satisfy the current capacity requirements.

3 Installation (continued)

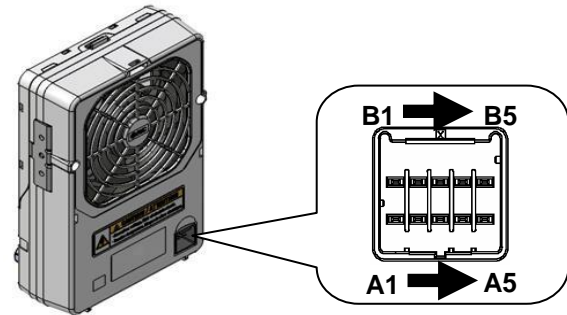

Wiring

Connector pin No.	Cable colour	Signal name	Signal direction	Description
A1	Brown	24 VDC	IN	Connect power supply to operate the ionizer.
B1	Blue	0 V	IN	
A2	Green	F.G.	-	Connect to ground with a resistance of 100 Ω or less, to use it as a reference electric potential for ionizer.
B2	Yellowish Green	Ionizer stop signal	IN	Signal input to turn ON/OFF the ventilation with fan and ion generation. NPN specification: Ventilation and ion generation is stopped by connecting to 0 V. (continues to operate when disconnected) PNP specification: Ventilation and ion generation is stopped by connecting to +24 VDC. (continues to operate when disconnected)
A3	Grey	Cleaning signal	IN	If the automatic cleaning unit (option) is mounted, emitters are cleaned when the signal is input. The ion generation and fan motor rotation will be stopped during cleaning.
B3	Yellow	Maintenance signal	OUT (Contact A)	Signal is ON when contamination or wear of the emitter is detected, when balance cannot be adjusted by the built-in sensor, or when the automatic cleaning is performed (for product with an automatic cleaning unit).
A4	Purple	Error signal	OUT (Contact B)	Signal is OFF during power supply failure, incorrect high voltage, fan motor failure, CPU failure, excessive current in the output circuit, emitter cartridge mounting failure, or automatic cleaning failure (for product with an automatic cleaning unit) is detected. (Signal is ON when there is no problem)
B4	White	Unused	-	
A5				

3.3.3 Wiring of the AC Adapter

Perform F.G. connection with the ground terminal (F.G.) of the AC cord when an AC adapter is used. If the AC cord is plugged in, plug it into a grounded outlet. Always use an AC cord with ground terminal if it is prepared by the user.

The ground terminal (F.G.) is used as an electrical reference potential for static neutralization. If the ground terminal is not grounded, the ionizer will not be able to achieve the optimal offset voltage (ion balance).

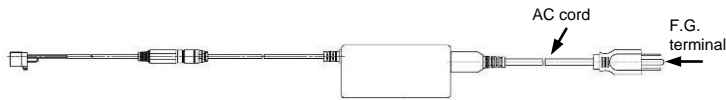

3.4 Function

3.4.1 Name of Parts

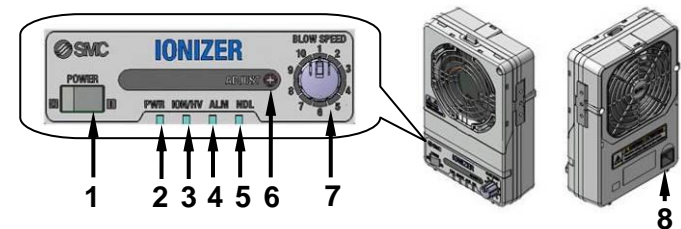

No.	Name	Panel display	Type	Description
1	Power supply switch	POWER	Switch	Switch to turn the ionizer on and off.
2	Power supply indicator	PWR	LED (Green/Red)	Green LED is ON when the power supply is ON; green LED flashes when the power supply is abnormal; and red LED flashes when the CPU is abnormal.
3	Static neutralization operation/incorrect high voltage	ION / HV	LED (Green/Red)	Green LED is ON when static neutralization is operated; red LED is ON when incorrect high voltage is detected; and red LED flashes when the CPU is abnormal.
4	Error indicator	ALM	LED (Red)	Red LED is ON constantly during fan motor failure or automatic cleaning failure is detected; and red LED flashes when the CPU is abnormal.
5	Maintenance indicator	NDL	LED (Green/Red)	Green LED is ON when contamination of the emitters is detected; red LED is ON when emitter cartridge mounting failure is detected; red LED flashes when automatic cleaning failure or CPU failure is detected; and green LED flashes during automatic cleaning operation.
6	Balance adjustment	ADJUST	Trimmer	Trimmer for offset voltage (ion balance) adjustment. Refer to "4-2. Adjustment of Offset Voltage" for details.
7	Air flow adjustment	BLOW SPEED	Rotary switch	Switch for adjustment of air flow with fan. Refer to "4-3. Adjustment of Air Flow" for details.
8	Connector	-	Connector	Connector for Power supply, F.G., and input/output signals.

3 Installation (continued)

3.4.2 Alarm Function

If abnormal functions occur during operation of the ionizer, the user will be alerted by the external output signal and by the LED operation.

Alarm name	Output signal	LED ON	LED (Flashes at 1Hz)	Ionizer operation during alarm	Description	Action to reset alarm
Power supply failure	Error signal OFF (B contact)	N/A	PWR (green)	Stop	Connected power supply voltage is outside of specification.	Resets automatically.
High voltage error	Error signal OFF (B contact)	ION/HV (red)	N/A	Stop	Error in the high voltage discharge circuit.	Cycle ionizer stop signal ON/OFF Cycle power OFF/ON
Fan motor failure	Error signal OFF (B contact)	ALM (red)	-	Stop	Incorrect ionizer operation due to foreign matter in fan motor.	Cycle ionizer stop signal ON/OFF Cycle power OFF/ON
CPU failure	Error signal OFF (B contact)	-	PWR (red) ION/HV (red) ALM (red) NDL (red)	Stop	CPU error due to noise etc.	Cycle power OFF/ON
Output signal over current	Error signal OFF (B contact) Maintenance signal ON (A contact)	-	-	Continue	Protection circuit activated by excess current in the output signal.	Resets automatically.
Maintenance warning	Maintenance signal ON (A contact)	NDL (green)	-	Continue	Static electricity neutralization performance is reduced due to contamination, wear or damage to emitters.	Cycle ionizer stop signal ON/OFF Cycle power OFF/ON
Emitter cartridge not fitted	Error signal OFF (B contact)	NDL (red)	N/A	Stop	Emitter cartridge not fitted	Cycle power OFF/ON
Automatic cleaning function error	Error signal OFF (B contact)	ALM (red)	NDL (red)	Stop	Error during automatic cleaning operation.	Cycle power OFF/ON

1) Power supply failure

If the power supply connected to the ionizer is not within the range of 24 V +/-10%, the abnormal signal will be turned OFF (ON when it is normal), and the PWR LED (green) will flash to indicate the error.

When failure occurs, the fan motor rotation and ion generation will be stopped.

To resolve the error, reset the product automatically and connect a power supply which provides a power supply voltage of 24 V +/-10%.

2) Incorrect high voltage

When an incorrect electrical discharge is generated during the ionizer operation, the abnormal signal will be turned OFF (ON when it is normal), and the ION/HV LED (red) will light up to indicate the error.

If a failure occurs, the fan motor rotation and ion generation will stop.

The incorrect electric discharge could be caused by condensation or dust on the emitters. To resolve the error, input the ionizer stop signal and after remedying the cause of the incorrect electric discharge supply power again.

3) Fan motor failure

If the fan motor malfunctions during ionizer operation, the abnormal signal will be turned OFF (ON when it is normal), and the ALM LED (red) will turn ON to indicate the error.

If failure occurs, the fan motor rotation and ion generation will stop.

The fan motor failure could be caused by failure of the rotational operation due to foreign matter entwined in the fan motor. To resolve the error, input the ionizer stop signal and after removing the foreign matter supply power again.

4) CPU failure

If the CPU makes an abnormal operation due to noise or other reasons, the abnormal signal will be turned OFF (ON when it is normal), and the PWR, ION-HV, ALM, and NDL LED (red) will flash to indicate an error.

If failure occurs, the fan motor rotation and ion generation will stop.

To prevent noise, perform the following actions and countermeasures.

1. Position the ionizer away from any noise source.
2. Route the power line and cables for the ionizer separately.
3. Install a noise filter to the power supply of the ionizer.

To resolve the error, after fixing the cause of the error, supply power again.

5) Output signal over current

When excessive current flows to the output circuit, the output will be blocked to protect the circuit and the abnormal signal will be turned OFF (ON when it is normal) to indicate an error.

The ionizer operates even when excessive current is generated in the output circuit. To resolve the error, reset the product automatically by reducing the current to the output circuit to 100 mA or less.

6) Maintenance warning

The maintenance signal will turn ON when contamination, wear or breakage of the emitters is detected. The NDL LED (green) will turn ON to indicate that cleaning or replacement of the emitters is required.

The ionizer operates even when the maintenance warning is generated.

3 Installation (continued)

When emitters are contaminated, the error can be solved by cleaning them. However, when they are worn out or damaged, it is necessary to replace the emitter cartridge with a new one. To resolve the error, input the ionizer stop signal and after remedying the cause of the error supply power again.

7) Emitter cartridge mounting failure

If the emitter cartridge is not mounted; or if power is supplied while the emitter cartridge is not mounted in the correct position; or when the correct emitter cartridge mounting cannot be detected due to foreign matter inside the terminals which detect connection of the emitter cartridge, the abnormal signal will be turned OFF (ON when it is normal), and NDL LED (red) will turn ON to indicate an error.

When failure occurs, the fan motor rotation and ion generation will stop. To solve the error, remount the emitter cartridge in the correct position or remove the foreign matter adhered to the terminals and supply power again.

8) Automatic cleaning failure (for product with an automatic cleaning unit)

If the cleaning operation is not completed in the specified time, the abnormal signal will be turned OFF (ON when it is normal), the ALM LED (red) will turn ON, and the NDL LED (red) will flash to indicate an error.

The automatic cleaning operation failure could be caused by foreign matter entwined in the cleaning parts, or by malfunction of the magnetic type origin detection sensor due to environmental magnetic field. To resolve the error, after removing the foreign matter and/or magnetic field, supply power again.

3.4.3 Other Functions

- Offset Voltage Performance Maintaining Function
- Ion Balance Sensor
- Averaging Function
- Automatic Cleaning Unit (option)
- Louver (option)
- Filter (option)

For further details refer to the operation manual for this product.

4 Settings

4.1 Adjustment of Offset Voltage

Although the offset voltage (ion balance) of this product has been adjusted before shipping, readjustment may be required depending on the installation environment or conditions. Adjustment can be performed using a balance adjusting trimmer which is labelled as ADJUST.

When adjusting the offset voltage (ion balance), use a measuring instrument such as a charge plate monitor.

As described in "4-7-2. Averaging Function", this product exchanges the polarity of voltage applied to the emitters. After adjusting the offset voltage (ion balance), supply power again to exchange the polarity of voltage applied to the emitters. Then, adjust the offset voltage (ion balance) again after rotating the trimmer to the end and returning it. In addition, adjustment of the offset voltage (ion balance) may be required after replacing the emitter cartridge.

Rotating the balance adjusting trimmer in a clockwise direction increases positive ions, and rotating it in a counter-clockwise direction increases negative ions.

Balance adjusting trimmer

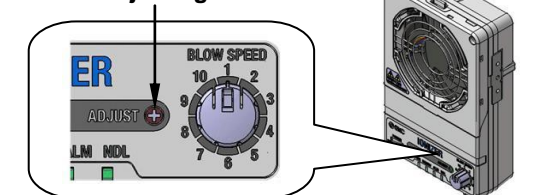

7 Maintenance (continued)

4) Fit the emitter cartridge back in its original position by following the removal procedure in reverse.

Remount the emitter cartridge so that the terminals on the body contact with the terminals on the emitter cartridge. Be careful that no contact failure or short circuit caused by adhesion of foreign matter occurs when connecting the terminals.

Make sure that no foreign matter is adhered to the body of the connector.

The recommended tightening torque for the emitter cartridge retaining screw is 0.25 to 0.35 Nm.

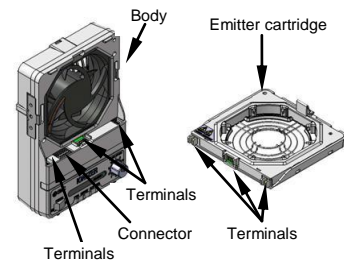

8 Limitations of Use

Warning

Do not exceed any of the specifications laid out in section 7 of the operation manual or in the product catalogue.

9 WEEE Directive

This product is classified as Waste Electrical or Electronic Equipment according to the WEEE Directive 2012/19/EU and should not be disposed of as municipal waste, in order to reduce the impact on human health and the environment.

10 Contacts

AUSTRIA	(43) 2262 62280-0	LATVIA	(371) 781 77 00
BELGIUM	(32) 3 355 1464	LITHUANIA	(370) 5 264 8126
BULGARIA	(359) 2 974 4492	NETHERLANDS	(31) 20 531 8888
CZECH REP.	(420) 541 424 611	NORWAY	(47) 67 12 90 20
DENMARK	(45) 7025 2900	POLAND	(48) 22 211 9600
ESTONIA	(372) 651 0370	PORTUGAL	(351) 21 471 1880
FINLAND	(358) 207 513513	ROMANIA	(40) 21 320 5111
FRANCE	(33) 1 6476 1000	SLOVAKIA	(421) 2 444 56725
GERMANY	(49) 6103 4020	SLOVENIA	(386) 73 885 412
GREECE	(30) 210 271 7265	SPAIN	(34) 945 184 100
HUNGARY	(36) 23 511 390	SWEDEN	(46) 8 603 1200
IRELAND	(353) 1 403 9000	SWITZERLAND	(41) 52 396 3131
ITALY	(39) 02 92711	UNITED KINGDOM	(44) 1908 563888

SMC Corporation

URL : [http:// www.smcworld.com](http://www.smcworld.com) (Global) <http:// www.smceu.com> (Europe)

Specifications are subject to change without prior notice from the manufacturer.

© 2015 SMC Corporation All Rights Reserved.