



**Installation and Maintenance Manual**  
**Electro-Pneumatic Regulator**  
**Series ITV1000-Q**



**1 Safety Instructions**

This manual contains essential information for the protection of users and others from possible injury and/or equipment damage.

- Read this manual before using the product, to ensure correct handling, and read the manuals of related apparatus before use.
- Keep this manual in a safe place for future reference.
- These instructions indicate the level of potential hazard by label of "Caution", "Warning" or "Danger", followed by important safety information which must be carefully followed.
- To ensure safety of personnel and equipment the safety instructions in this manual and the product catalogue must be observed, along with other relevant safety practices.

<b>Caution</b>	Indicates a hazard with a low level of risk, which if not avoided, could result in minor or moderate injury.
<b>Warning</b>	Indicates a hazard with a medium level of risk, which if not avoided, could result in death or serious injury.
<b>Danger</b>	Indicates a hazard with a high level of risk, which if not avoided, will result in death or serious injury.

- Electromagnetic compatibility:  
 This product is class A equipment intended for use in an industrial environment. There may be potential difficulties in ensuring electromagnetic compatibility in other environments due to conducted as well as radiated disturbances.

**Warning**

- **The compatibility of pneumatic equipment is the responsibility of the person who designs the pneumatic system or decides its specifications.**  
 Since the products specified here can be used in various operating conditions, their compatibility with the specific pneumatic system must be based on specifications or after analysis and/or tests to meet specific requirements.
- **Only trained personnel should operate pneumatically operated machinery and equipment.**  
 Compressed air can be dangerous if an operator is unfamiliar with it. Assembly, handling or repair of pneumatic systems should be performed by trained and experienced personnel.
- **Do not service machinery/equipment or attempt to remove components until safety is confirmed.**  
 Inspection and maintenance of machinery/equipment should only be performed after confirmation of safe locked-out control positions.
- When equipment is to be removed, confirm the safety process as mentioned above. Switch off air and electrical supplies and exhaust all residual compressed air in the system.
- Before machinery/equipment is re-started, ensure all safety measures to prevent sudden movement of cylinders etc. (Supply air into the system gradually to create back pressure, i.e. incorporate a soft-start valve).
- **Do not use this product outside of the specifications. Contact SMC if it is to be used in any of the following conditions:**
  - Conditions and environments beyond the given specifications, or if the product is to be used outdoors.
  - Installations in conjunction with atomic energy, railway, air navigation, vehicles, medical equipment, food and beverage, recreation equipment, emergency stop circuits, press applications, or safety equipment.
  - An application, which has the possibility of having negative effects on people, property, or animals, requiring special safety analysis.

**Caution**

- Ensure that the air supply system is filtered to 5 microns.

**2 Specifications**

Model	ITV101*	ITV103*	ITV105*
Min. supply pressure	(Set pressure) + 0.1 MPa		
Max. supply pressure	0.2 MPa	1.0 MPa	
Set pressure range	0.005 ~ 0.1 MPa	0.005 ~ 0.5 MPa	0.005 ~ 0.9 MPa
Supply voltage	24 VDC±10%, 12 to 15 VDC		
Current consumption	24 VDC	Max. 120 mA	
	12 VDC	Max. 180 mA	
Input signal	Current type <sup>Note1</sup>	4-20 mA DC, 0-20 mA DC	
	Voltage type	0-5 VDC, 0-10 VDC	
	Preset input type	Max. 4 steps	
Input impedance	Current type	Max. 250 Ω <sup>Note 4</sup>	
	Voltage type	Approx. 6.5 kΩ	
	Preset input type	Approx. 2.7 kΩ	
Output signal <sup>Note2</sup>	Analogue	1-5 VDC (Load Impedance: 1kΩ or more)	
	Switch	NPN - Open collector type: 30 V 30 mA PNP - Open collector type: 30 mA	
Linearity	Max. ±1%F.S.		
Hysteresis	Max. 0.5%F.S.		
Repeatability	Max. ±0.5%F.S.		
Sensitivity	Max. 0.2%F.S.		
Temperature characteristics	Max. ±0.12%F.S./°C		
Operating temperature	0~50°C (without condensation)		
Pressure display	Accuracy	±3%F.S.	
	Min. Unit	MPa: 0.01, kgf/cm <sup>2</sup> : 0.01, bar: 0.01, PSI: 0.1 <sup>Note 3</sup> , kPa: 1	
Protection structure	Main unit: IP65, Cable connector: IP67		

Note 1: Two wire control, 4 to 20 mA DC and 0 to 20 mA DC are not available. Supply voltage of 12-15VDC or 24 VDC is required.  
 Note 2: Make selection of analogue or switch output; also select NPN or PNP output when switch output is selected.  
 Note 3: 1 PSI is the minimum unit on ITV105\*.  
 Note 4: Value for the state with no over current included. If an allowance is provided for an over current circuit, the input impedance varies depending on the input current. This is 350 Ω or less for an input current of 20 mA DC.

**3 Operation Principle**

When the input signal increases the supply solenoid valve ① turns on and the exhaust solenoid valve ② turns off. Supply pressure is passed to the pilot valve ③ through the supply solenoid valve. The pilot valve will open the main valve allowing partial supply pressure to pass to the out port. The pressure sensor ④ will provide output pressure feedback to the control circuit ⑤. The control circuit will balance the input signal and output pressure to ensure that the output pressure remains proportional to the input signal.

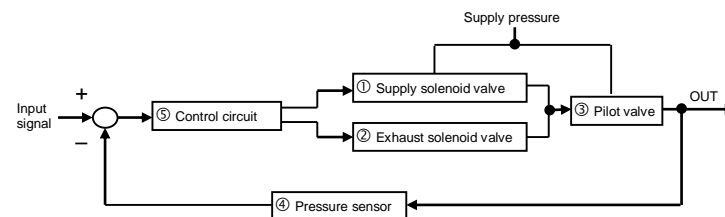

Fig. 1 - Control diagram

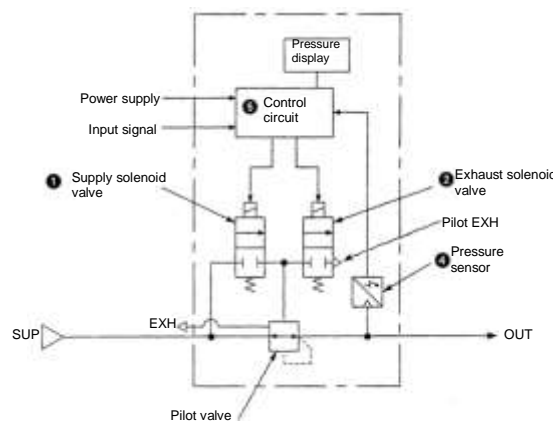

Fig. 2 - Schematic diagram

**4 Wiring**

**Caution**

Connect the cable to the connector on the main unit as shown in the following diagram. Take precautions, as incorrect wiring will damage the unit. Use a DC power supply capable of supplying the necessary power requirements with minimal ripple.

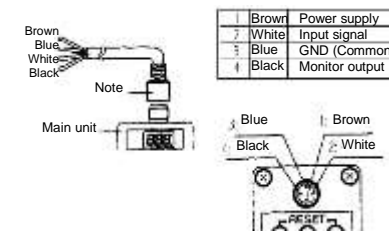

Fig. 3 - Connection details  
 Note: The right angle type connector extends to the left side (over the supply port side)

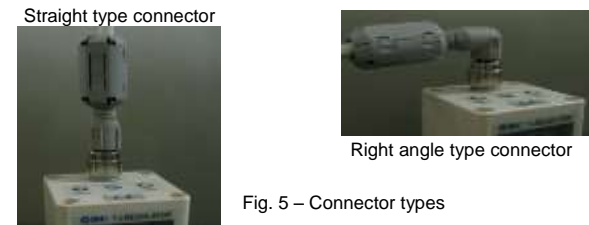
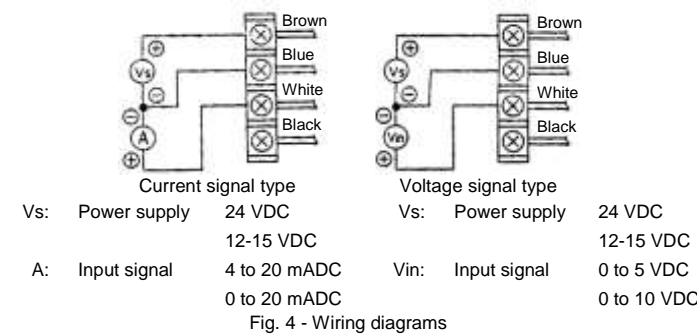

Fig. 5 - Connector types

**5 Setting the Regulator**

**Caution**

When the 'set' key is operated minimum/maximum pressure will be present at the outlet port. When primary pressure is applied to the regulator minimum pressure will be present at the outlet port.

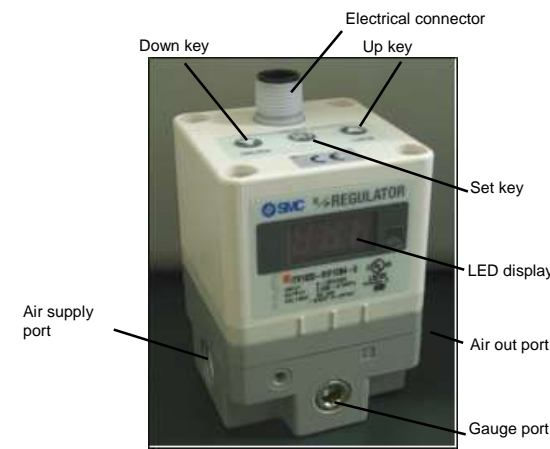

Fig. 6 - Key features of the ITV.

- Release 'Key Lock' as explained in section 'Function of Key-Lock'
- After releasing key lock, SET needs to be pressed again to get to F-1
- To set minimum pressure (display shows F-1) use up/down keys and press 'Set' key to 'Lock' setting.
- To set maximum pressure (display shows F-2) use up/down keys and press 'Set' key to 'Lock' setting.

Note 1: If the above sequence has been followed correctly, the settings will complete automatically.

Note 2: If only setting minimum pressure, when pressure is 'Set', pressing the set button once more will 'skip' to the next step..

**6 Function of Key-Lock**

The keys are locked after connecting power and cannot be operated. 'Loc' is displayed when any keys are pushed.

- Key-Lock Release
- Push 'Down' key for longer than 2 seconds.
- Display will flash 'Loc' (locked).
- Push 'Set' key to unlock.
- Note: To cancel push 'Up' key.

- Key-Lock Push 'Up' key for longer than 2 seconds.
- Display will flash 'unL' (unlocked).
- Push 'Set' key to lock.
- Note: To cancel push 'Down' key.

**7 Function of the 'Error' Display**

If an abnormality is detected by the ITV the LED display will show 'Er' followed by a code number. Isolate the power supply and ascertain the problem and solve. Re-instate power supply after correcting fault. Error codes are as shown in the table below.

No	Content	Display
1	Input signal is outside specification	Er 1
2	EEPROM read/write error	Er 2
3	Memory read/write error	Er 3
4	Solenoid valve fault	Er 4
5	Switch output over-current	Er 5

**8 Reset Function**

- Push 'Up' and 'Down' keys (Fig 6) together for longer than 3 seconds.
- Display shows 'RES'.
- Release keys to reset minimum pressure and maximum pressure.

**9 Installation & Maintenance**

**Caution**

- If the electrical supply fails, settings are 'held' for a short period.
- If the air pressure fails with power 'on' the solenoid will 'flutter'. Turn off the power.
- If the monitor output function is not used, ensure that the wire is totally insulated.
- This product is pre-set at the factory and must not be dismantled by the user. Contact your local SMC office for advice.
- Ensure, when installing this product, that it is kept clear of power lines to avoid noise interference.
- Ensure that load surge protection is fitted when inductive loads are present (i.e. solenoid, relay etc.).
- Ensure precautions are in place if the product is used in a 'free flow output' condition. Air will continue to flow continuously.
- Do not use a lubricator on the input side of this product. If lubrication is necessary, place the lubricator on the 'output' side.
- Ensure all air is exhausted from the product before maintenance.
- Length of connector cable shall be 10 m maximum.

**10 Contacts**

AUSTRIA	(43) 2262 62280	NETHERLANDS	(31) 20 531 8888
BELGIUM	(32) 3 355 1464	NORWAY	(47) 67 12 90 20
CZECH REP.	(420) 541 424 611	POLAND	(48) 22 211 9600
DENMARK	(45) 7025 2900	PORTUGAL	(351) 21 471 1880
FINLAND	(358) 207 513513	SLOVAKIA	(421) 2 444 56725
FRANCE	(33) 1 6476 1000	SLOVENIA	(386) 73 885 412
GERMANY	(49) 6103 4020	SPAIN	(34) 945 184 100
GREECE	(30) 210 271 7265	SWEDEN	(46) 8 603 1200
HUNGARY	(36) 23 511 390	SWITZERLAND	(41) 52 396 3131
IRELAND	(353) 1 403 9000	UNITED KINGDOM	(44) 1908 563888
ITALY	(39) 02 92711		

**SMC Corporation**

URL : <http://www.smcworld.com> (Global) <http://www.smceu.com> (Europe)  
 Specifications are subject to change without prior notice from the manufacturer.  
 © 2009 SMC Corporation All Rights Reserved.