



## Installation & Maintenance Manual Auto Switch (Solid State)

Series D-M9NA/D-M9NAV

Series D-M9PA/D-M9PAV

Series D-M9BA/D-M9BAV



### 1 Safety Instructions

This manual contains essential information for the protection of users and others from possible injury and/or equipment damage.

- Read this manual before using the product, to ensure correct handling, and read the manuals of related apparatus before use.
- Keep this manual in a safe place for future reference.
- These instructions indicate the level of potential hazard by label of "Caution", "Warning" or "Danger", followed by important safety information which must be carefully followed.
- To ensure safety of personnel and equipment the safety instructions in this manual and the product catalogue must be observed, along with other relevant safety practices.

<b>Caution</b>	CAUTION indicates a hazard with a low level of risk which, if not avoided, could result in minor or moderate injury.
<b>Warning</b>	WARNING indicates a hazard with a medium level of risk which, if not avoided, could result in death or serious injury.
<b>Danger</b>	DANGER indicates a hazard with a high level of risk which, if not avoided, will result in death or serious injury.

This product is class A equipment that is intended for use in an industrial environment.

There may be potential difficulties in ensuring electromagnetic compatibility in other environments due to conducted as well as radiated disturbances.

### Warning

1. The compatibility of pneumatic equipment is the responsibility of the person who designs the pneumatic system or decides its specifications.
  - Since the products specified here are used in various operating conditions, their compatibility for the specific pneumatic system must be based on specifications or after analysis and/or tests to meet your specific requirements.
2. Only trained personnel should operate pneumatically operated machinery and equipment.
  - Compressed air can be dangerous if an operator is unfamiliar with it. Assembly, handling or repair of pneumatic systems should be performed by trained and experienced operators.
3. Do not service machinery/equipment or attempt to remove component until safety is confirmed.
  - Inspection and maintenance of machinery/equipment should only be performed after confirmation of safe locked-out control positions.
  - When equipment is to be removed, confirm the safety process as mentioned above. Switch off air and electrical supplies and exhaust all residual compressed air in the system.
  - Before machinery/equipment is re-started, ensure all safety measures to prevent sudden movement of actuators etc. (Supply air into the system gradually to create backpressure, i.e. incorporate a soft-start valve).

### 1 Safety Instructions (Continued)

#### Warning

4. Contact SMC if the product is to be used in any of the following conditions:
  - Conditions and environments beyond the given specifications, or if product is used outdoors.
  - Installations in conjunction with atomic energy, railway, air navigation, vehicles, medical equipment, food and beverage, recreation equipment, emergency stop circuits, press applications, or safety equipment.
  - Applications which have the possibility of having negative effects on people, property or animals. Special safety analysis is required.

### 2 Installation and Operating Environment

#### Warning

#### Design and selection

1. Confirm the specifications.
 

Read the specifications carefully and use this product appropriately. The product may be damaged or malfunction if it is used outside the range of specifications for load current, voltage, temperature or impact.
2. Take precautions when multiple actuators are used close together.
 

When multiple auto switch actuators are used in close proximity, magnetic field interference may cause the switches to malfunction. Maintain a minimum actuator separation of 40 mm.
3. Pay attention to the length of time that a switch is ON at an intermediate stroke position.
 

When an auto switch is placed at an intermediate position of the stroke and a load is driven at the time the piston passes, the auto switch will operate, but if the speed is too great the operating time will be shortened and the load may not operate properly. The maximum detectable piston speed is:

$$V[\text{mm/s}] = \frac{\text{Autoswitch operating range [mm]} \times 1000}{\text{Load operating time [ms]}}$$
4. Keep wiring as short as possible.
 

Although longer wiring does not affect the function, please keep it to 100 m or shorter.
5. Do not use a load that generates surge voltage.
 

Although a zener diode for surge protection is connected at the output side of a solid state auto switch, damage may still occur if the surge is applied repeatedly. When a load such as a relay or solenoid which generates surge is directly driven, use a type of switch with a built-in surge absorbing element.
6. Cautions for use in an interlock circuit
 

When an auto switch is used for an interlock signal requiring high reliability, devise a double interlock system to avoid trouble by providing a mechanical protection function, or by also using another switch (sensor) together with the auto switch.

Also perform periodic maintenance and confirm proper operation.
7. Ensure sufficient clearance for maintenance activities.
 

When designing an application, be sure to allow sufficient clearance for maintenance and inspections.

### 2 Installation and Operating Environment (continued)

#### Warning

#### Mount / adjustment

1. Do not drop or bump.
 

Do not drop, bump or apply excessive impacts (1000 m/s<sup>2</sup> or more for solid state switches) while handling. Although the body of the switch may not be damaged, the inside of the switch could be damaged and cause a malfunction.
2. Do not carry a actuator by the auto switch lead wires.
 

Never carry a actuator by its lead wires. This may not only cause broken lead wires, but it may cause internal elements of the switch to be damaged by the stress.
3. Mount switches using the proper tightening torque.
 

If a switch is tightened beyond the range of tightening torque, the mounting screws, mounting brackets or switch may be damaged. On the other hand, tightening below the range of tightening torque may allow the switch to slip out of position.
4. Mount a switch at the center of the operating range.
 

Adjust the mounting position of an auto switch so that the piston stops at the center of the operating range (the range in which a switch is ON). (The mounting position shown in the catalog indicates the optimum position at stroke end.) If mounted at the end of the operating range (around the borderline of ON and OFF), operation may be unstable.

#### Wiring

1. Avoid repeatedly bending or stretching lead wires.
 

Broken lead wires can result from wiring patterns which repeatedly apply bending stress or stretching force to the lead wires.
2. Confirm proper insulation of wiring.
 

Be certain that there is no faulty wiring insulation (contact with other circuits, ground fault, improper insulation between terminals, etc.) Damage may occur due to excess current flow into a switch.
3. Do not wire with power lines or high voltage lines.
 

Wire separately from power lines or high voltage lines, avoiding parallel wiring or wiring in the same conduit with these lines. Control circuits containing auto switches may malfunction due to noise from these other lines.
4. Do not allow short circuit of loads.
 

All models of PNP output type switches do not have built-in short circuit protection circuits. Note that if a load is short circuited, the switch will be instantly damaged because of excess current flow into the switch.
5. Avoid incorrect wiring.
 

If incorrect wiring, the switches will be damaged.

### 2 Installation and Operating Environment (continued)

#### Operating environment

1. Do not use in an area where a magnetic field is generated.
 

Auto switches can malfunction or magnets inside actuators can become demagnetized.
2. Do not use in an environment where the auto switch will be continually exposed to water.
 

Although switches satisfy IEC standard IP67 construction (JIS C 0920: watertight construction), avoid using switches in applications where continually exposed to water splash or spray. Poor insulation or swelling of the potting resin inside switches may cause malfunction.
3. Do not use in an environment with oil or chemicals.
 

Consult SMC if auto switches will be used in an environment with coolant, cleaning solvent, various oils or chemicals. If auto switches are used under these conditions for even a short time, they may be adversely affected by improper insulation, malfunction due to swelling of the potting resin, or hardening of the lead wires.
4. Do not use in an environment with temperature cycles.
 

Consult SMC if switches are used where there are temperature cycles other than normal air temperature changes, as there may be adverse effects inside the switches.
5. Do not use in an area where surges are generated.
 

When there are units (solenoid type lifter, high frequency induction furnace, motor, etc.) which generate a large amount of surge in the area around actuators with solid state auto switches, this may cause deterioration or damage to the switches. Avoid sources of surge generation and crossed lines.
6. Avoid accumulation of iron waste or close contact with magnetic substances.
 

When a large amount of iron waste such as machining chips or spatter is accumulated, or a magnetic substance (something attracted by a magnet) is brought into close proximity with an auto switch actuator, it may cause auto switches to malfunction due to a loss of the magnetic force inside the actuator.

#### Maintenance

1. Perform the following maintenance periodically in order to prevent possible danger due to unexpected auto switch malfunction.
  - 1) Securely tighten switch mounting screws.
 

If screws become loose or the mounting position is dislocated, retighten them after readjusting the mounting position.
  - 2) Confirm that there is no damage to lead wires.
 

To prevent faulty insulation, replace switches or repair lead wires, etc., if damage is discovered.

#### Others

1. For durability against water, elasticity, application at welding site, please consult us.
2. If ON and OFF position (hysteresis) cause problems, please consult us.

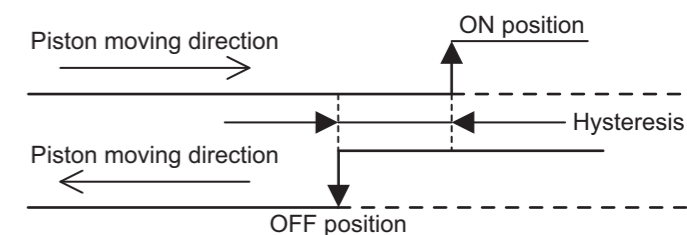

### 3 Model Indication Method

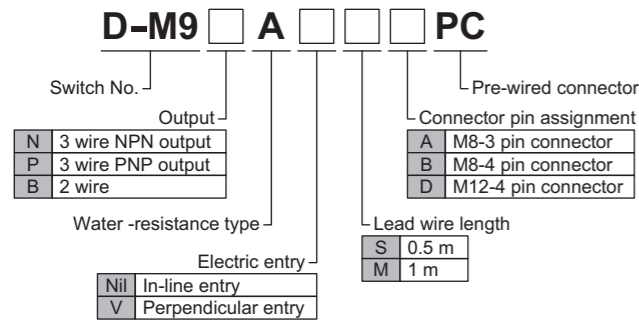
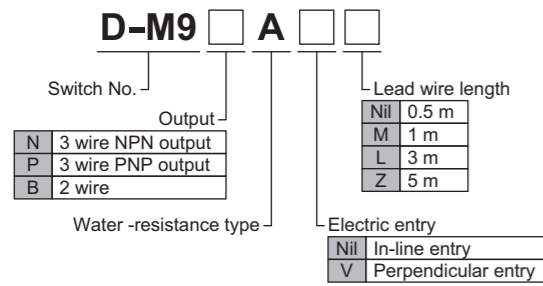

This product is a Solid State Auto Switch of direct mounting specification. Switch should only be used in areas in which potentially explosive atmospheres are unlikely to be present or only present for short periods of time.

### 4 Specification

•Oilproof heavy-duty lead wire specifications

Switch part no.	D-M9NA#	D-M9NAV#	D-M9PA#	D-M9PAV#	D-M9BA#	D-M9BAV#
Sheath	Outside diameter (mm)	2.6	2.7 x 3.2 oval	2.6	2.7 x 3.2 oval	2.6
Wires		3-wire (Brown, Blue, Black)			2-wire (Brown, Blue)	
Insulator	Outside diameter (mm)	0.88	0.9	0.88	0.9	0.88
Cross section (mm <sup>2</sup> )		0.15				
Conductor	Wire diameter (mm)	0.05				
Minimum bending radius (mm) (Reference value)		17	20	17	20	17

### 6 How to Mount / Mounting Bracket

Each actuator has a specified mounting bracket when mounted to the auto switch. "How to mount/Mount bracket" depends on actuator type and tube I.D. Please refer the actuator catalogue. When an auto switch is mounted for the first time, please ensure the actuator is magnet built-in type, then prepare the corresponding brackets for the actuator.

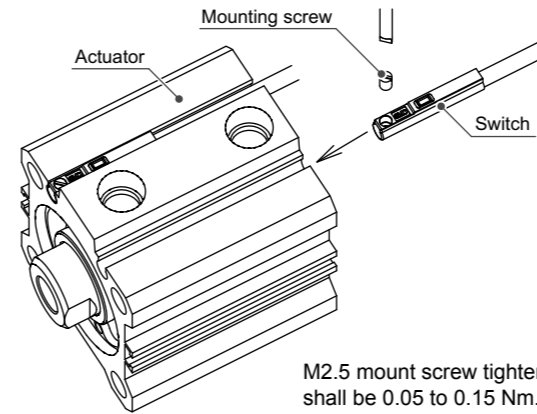

M2.5 mount screw tightening torque shall be 0.05 to 0.15 Nm.

- Setting the detecting position  
Set the actuator at the stroke end. Set the switch in the area to where the auto switch red lamp lights. (Detecting actuator end)  
Based on A and B dimensions in the actuator catalogue, set the switch.

### 8 Exterior Dimension

D-M9NA  
D-M9PA  
D-M9BA

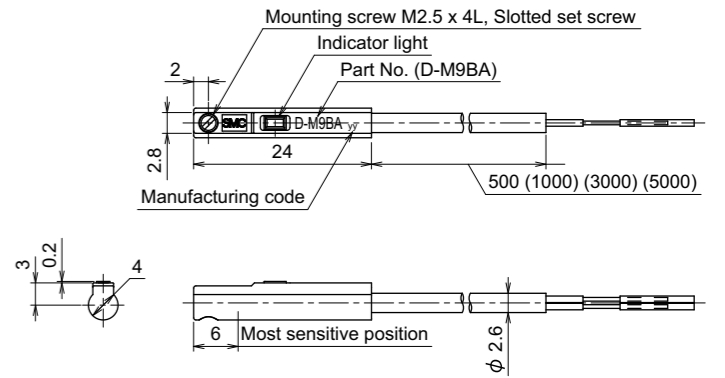

### 4 Specification

The auto switch should be used within the range of specifications below and the auto switch catalogue.

If labelled with X: special conditions applied:

1. Protect the auto switch against all impact or mechanical damage.
2. Protect the auto switch from sources of heat which can generate surface temperatures higher than the temperature classification.
3. The switch should not be exposed to prolonged sunlight or UV light that can generate surface temperatures higher than the temperature classification. Use a suitable protective cover.

Switch model No.	D-M9NA(V)	D-M9PA(V)	D-M9BA(V)
Wiring	3 wire		2 wire
Output	NPN	PNP	-
Power voltage	4.5 to 28 VDC		-
Current consumption	10 mA or less		-
Load voltage	28 VDC or less	-	10 to 28 VDC
Load current	40 mA or less		2.5 to 40 mA
Internal voltage drop	0.8 V or less at 10 mA (2 V or less at 40 mA)		4 V or less
Current leakage	100 μA or less at 24 VDC		0.8 mA or less
Operating time	1 ms or less		
Indication light	ON: (operating position) Red LED is ON ON: (optimum position) Green LED is ON OFF: LED is OFF		
Electrical entry system	Grommet		
Impact resistance	1000 m/s <sup>2</sup>		
Insulation resistance	50 MΩ or more under the test voltage 500 VDC (between case and cable)		
Withstand voltage	1000 VAC for 1 minute (between case and cable)		
Ambient temperature	-10 to 60 °C		
Protection structure	IEC60529 criteria IP67, JISC0920 watertight construction		
Standard	CE marked		

### 5 Names and Function of Individual Parts

D-M9NA  
D-M9PA  
D-M9BA

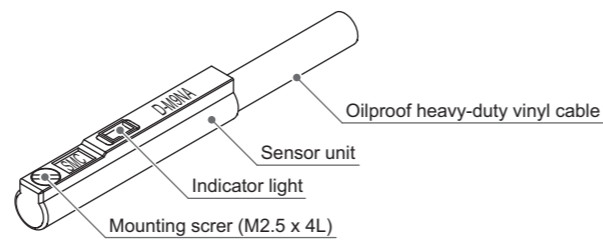

D-M9NAV  
D-M9PAV  
D-M9BAV

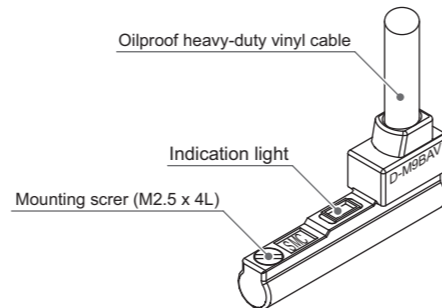

### 7 Basic Wiring

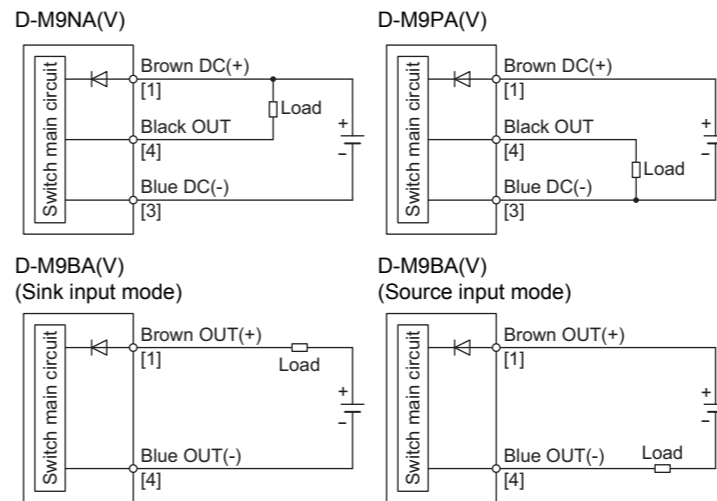

The number shown in brackets [ ] in the circuit diagram indicates the connector pin number.

#### Connector Pin Assignment

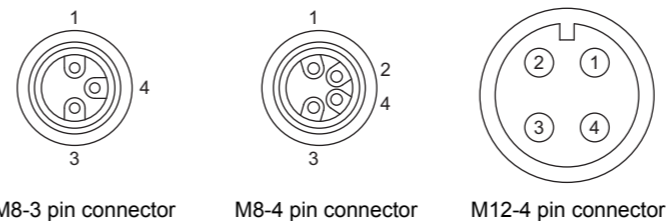

D-M9BAV

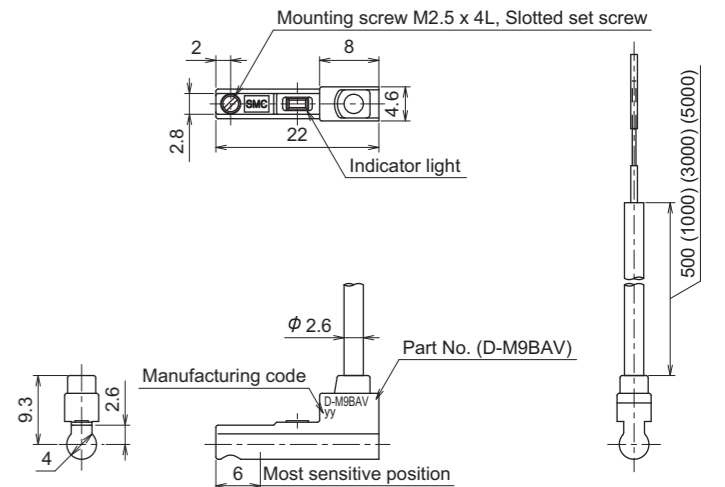

### 8 Exterior Dimension (Continued)

D-M9NAV  
D-M9PAV

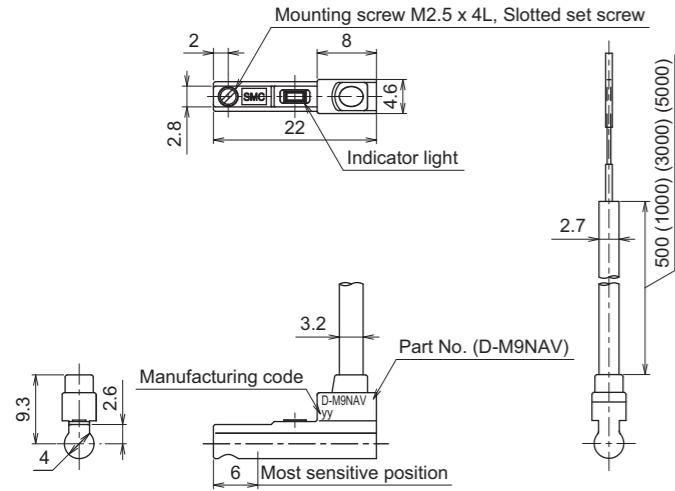

### 9 Troubleshooting

When detection failure occurs (stays ON/OFF), please check based on the following flow chart.

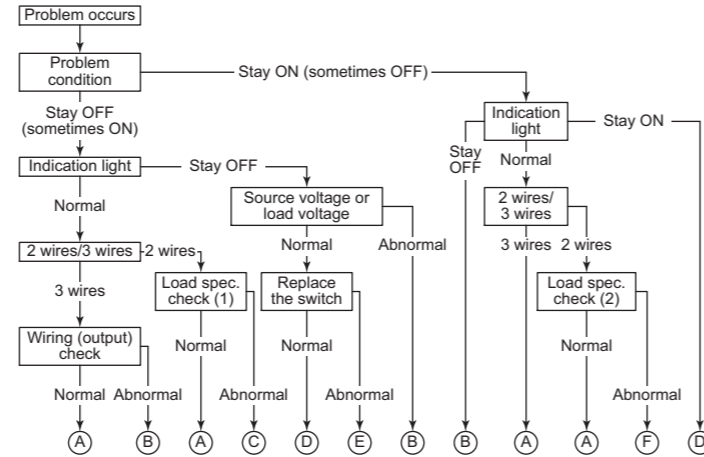

- Ⓐ : Switch output failure (replace)
- Ⓑ : Check wiring and correct fault
- Ⓒ : Replace switch 2 wires --> 3 wires
- Ⓓ : Switch failure
- Ⓔ : Replace cylinder. Detectable magnet field inadequate (No magnet)
- Ⓕ : Replace PLC input board or replace switch 2 wires --> 3 wires

Load spec. check (1): ON voltage > Load voltage-Internal voltage drop  
Load spec. check (2): OFF current > Leak current

### Manufacturing code

Year		Month	
Mark	Month	Mark	Month
V	2017	o	1
W	2018	P	2
X	2019	Q	3
Y	2020	R	4
:	:	:	:
		y	11
		Z	12

### Manufacturing code

D-M9 □ A □ □ <sup>A</sup>/<sub>B</sub> PC

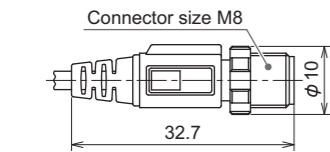

D-M9 □ A □ □ DPC

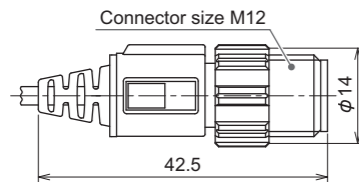

### 10 Contacts

AUSTRIA	(43) 2262 62280-0	LATVIA	(371) 781 77 00
BELGIUM	(32) 3 355 1464	LITHUANIA	(370) 5 264 8126
BULGARIA	(359) 2 974 4492	NETHERLANDS	(31) 20 531 8888
CZECH REP.	(420) 541 424 611	NORWAY	(47) 67 12 90 20
DENMARK	(45) 7025 2900	POLAND	(48) 22 211 9600
ESTONIA	(372) 651 0370	PORTUGAL	(351) 21 471 1880
FINLAND	(358) 207 513513	ROMANIA	(40) 21 320 5111
FRANCE	(33) 1 6476 1000	SLOVAKIA	(421) 2 444 56725
GERMANY	(49) 6103 4020	SLOVENIA	(386) 73 885 412
GREECE	(30) 210 271 7265	SPAIN	(34) 945 184 100
HUNGARY	(36) 23 511 390	SWEDEN	(46) 8 603 1200
IRELAND	(353) 1 403 9000	SWITZERLAND	(41) 52 396 3131
ITALY	(39) 02 92711	UNITED KINGDOM	(44) 1908 563888

### SMC Corporation

URL <http://www.smcworld.com> (Global) <http://www.smceu.com> (Europe)

Specifications are subject to change without prior notice from the manufacturer.  
© 2017 SMC Corporation All Rights Reserved