

Compact Cylinders/Double Clevis Pivot Bracket Series CQ2/CQS

Added pivot brackets for double clevis.

(For $\phi 12$ to $\phi 100$)

Rotating angle: Max. 100°

(For $\phi 12$, $\phi 16$)

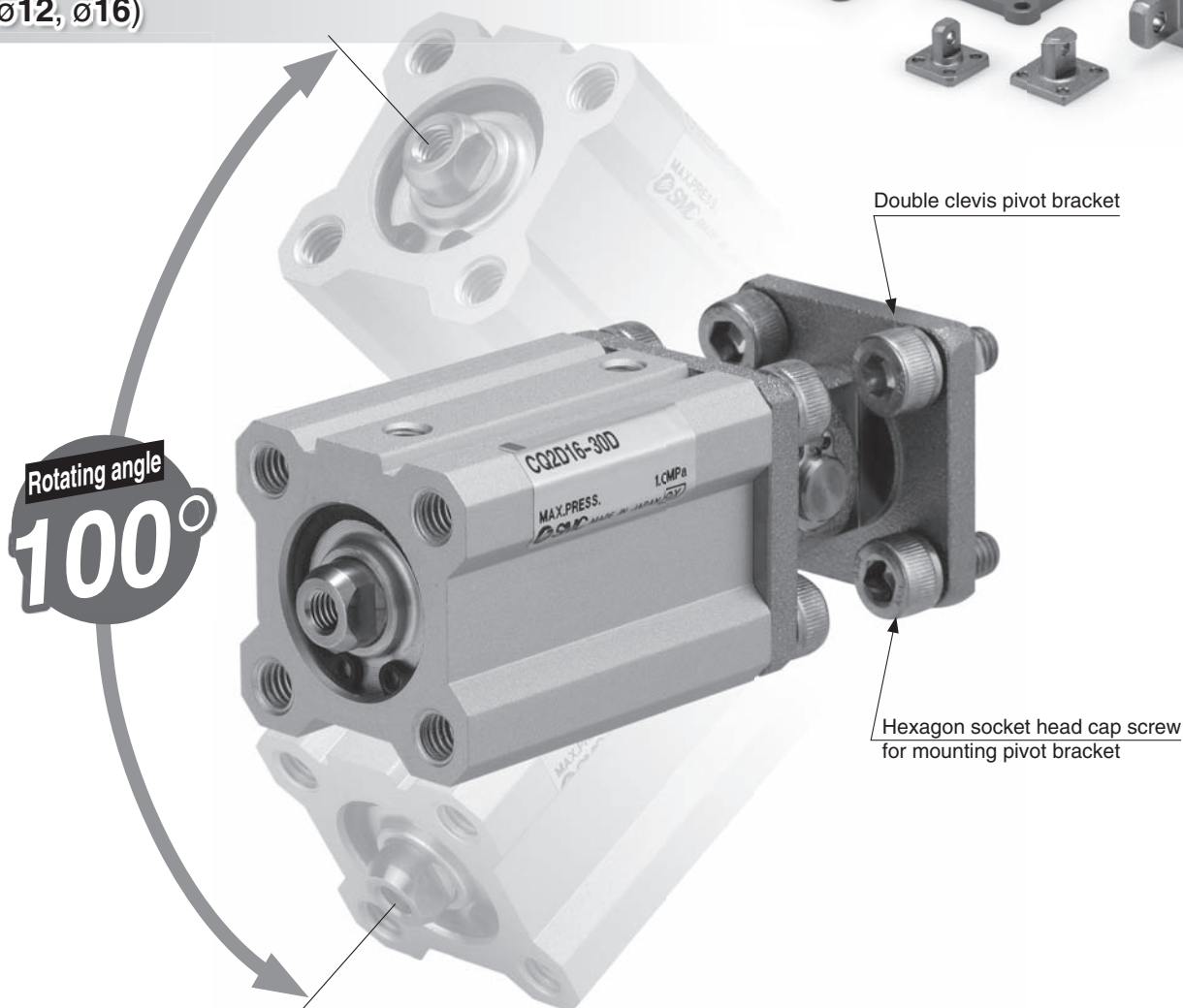
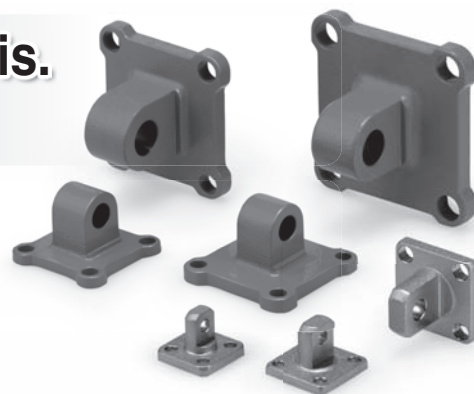

- Time to design rotating bracket saved.
- Improved amount of mounting freedom
- Can be mounted to an installed double clevis cylinder.

Applicable Cylinders

Product name	Model	Bore size	Note
Compact cylinder	CQ2	$\phi 12$ to $\phi 100$	Applicable only to double clevis.
	CQS	$\phi 12$ to $\phi 25$	Applicable only to double clevis.

Series CQ2/CQS

Double Clevis Pivot Bracket Dimensions/Part No.

Bore size $\varnothing 12$ to $\varnothing 25$ Without auto switch, With auto switch

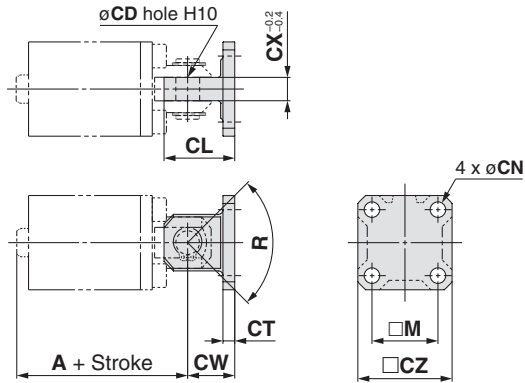

Applicable Cylinders/Double Clevis Pivot Bracket Part No.

(mm)

Model	Bracket part no.	Bore size	Stroke range	A		CW	CT	CL	CX	CD	M	CZ	R	CN	Hexagon socket head cap screw for mounting pivot bracket (Accessory)
				Without auto switch	With auto switch										
CQ2	CQ-C012	12	5 to 30	34.5	45.5	14	4	19	5	5	15.5	25	100°	4.5	M4 x 10 L
	CQ-C016	16	5 to 30	37	49	15	4	21	6.5	5	20	28	100°	4.5	M4 x 10 L
	CQ-C020	20	5 to 50	42	54	18	5	27	8	8	25.5	35	80°	6.6	M6 x 12 L
	CQ-C025	25	5 to 50	47.5	57.5	20	5	30	10	10	28	40	90°	6.6	M6 x 12 L
CQS	CQ-C012	12	5 to 30	34.5	39.5	14	4	19	5	5	15.5	25	100°	4.5	M4 x 10 L
	CQ-C016	16	5 to 30	35.5	40.5	15	4	21	6.5	5	20	28	100°	4.5	M4 x 10 L
	CQ-C020	20	5 to 50	42	52	18	5	27	8	8	25.5	35	80°	6.6	M6 x 12 L
	CQ-C025	25	5 to 50	47.5	57.5	20	5	30	10	10	28	40	90°	6.6	M6 x 12 L

* The double clevis pin and retaining ring are not included.

Double clevis pivot bracket material: Carbon steel
Surface treatment: Nickel plated

Bore size $\varnothing 32$ to $\varnothing 100$ Without auto switch, With auto switch

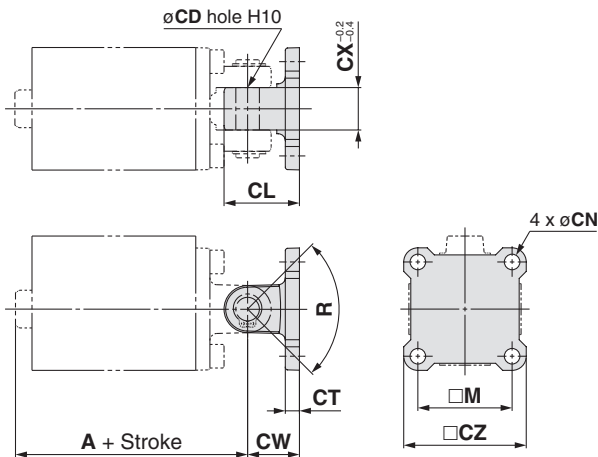

Applicable Cylinders/Double Clevis Pivot Bracket Part No.

(mm)

Model	Bracket part no.	Bore size	Stroke range	A		CW	CT	CL	CX	CD	M	CZ	R	CN	Hexagon socket head cap screw for mounting pivot bracket (Accessory)
				Without auto switch	With auto switch										
CQ2	CQ-C032	32	5 to 50	50	60	20	5	30	18	10	34	45	80°	6.6	M6 x 12 L
			75, 100	60											
	CQ-C040	40	5 to 50	58.5	68.5	22	6	32	18	10	40	52	80°	6.6	M6 x 14 L
			75, 100	68.5											
	CQ-C050	50	10 to 50	66.5	76.5	28	7	42	22	14	50	64	80°	9	M8 x 16 L
			75, 100	76.5											
	CQ-C063	63	10 to 50	74	84	30	8	44	22	14	60	77	60°	11	M10 x 20 L
			75, 100	84											
	CQ-C080	80	10 to 50	91.5	101.5	38	10	56	28	18	77	98	70°	13.5	M12 x 25 L
			75, 100	101.5											
	CQ-C100	100	10 to 50	110	120	45	13	67	32	22	94	117	70°	13.5	M12 x 30 L
			75, 100	120											

* The double clevis pin and retaining ring are not included.

Double clevis pivot bracket material: Cast iron
Surface treatment: Painted